

THE  
**NEW ZEALAND GAZETTE.**

Published by Authority.

WELLINGTON, THURSDAY, NOVEMBER 16, 1911.

*Laying out and taking a Road through Moerangi No. 1 Block, Karioi Survey District, Auckland Land District.*

(L.S.) ISLINGTON, Governor.  
A PROCLAMATION.

IN pursuance and exercise of the power conferred by section three hundred and eighty-eight of the Native Land Act, 1909, I, John Poynder Dickson-Poynder, Baron Islington, the Governor of the Dominion of New Zealand, do hereby lay out and take as a road the land described in the Schedule hereto.

**SCHEDULE.**

Approximate Area of each of the Parcels of Land taken.	Being Portion of	Situated in Block	Situated in Survey District of	Shown on Plan	Coloured on Plan
A. R. P. 0 2 25	Moerangi No. 1	XIV	Karioi	L. 57224/50	Purple.
1 1 19.3	"	"	"	"	"
0 3 37.7	"	"	"	"	"

All in the Auckland Land District; as the same are more particularly delineated on the plan marked and coloured as above mentioned, and deposited in the Head Office, Department of Lands, at Wellington. (Auckland Plan 16176, blue.)

Given under the hand of His Excellency the Right Honourable John Poynder Dickson-Poynder, Baron Islington, Governor and Commander-in-Chief in and over His Majesty's Dominion of New Zealand and its Dependencies; and issued under the Seal of the said Dominion, at the Government House, at Wellington, this eleventh day of November, in the year of our Lord one thousand nine hundred and eleven.

J. CARROLL,  
For Minister of Lands.

GOD SAVE THE KING!

A

*Land set apart for Selection.*

(L.S.) ISLINGTON, Governor.  
A PROCLAMATION.

WHEREAS by section seventy-seven of the New Zealand State-guaranteed Advances Act, 1909, as amended by section twenty-two of the New Zealand State-guaranteed Advances Amendment Act, 1910, it is, amongst other things, enacted that in no case shall any moneys be expended under the provision of the said section seventy-seven in connection with any block of land unless that block is set apart for selection under that section pursuant to Proclamation in that behalf:

Now, therefore, in pursuance and exercise of every power and authority enabling me in this behalf, and for the purposes of the aforesaid Acts, I, John Poynder Dickson-Poynder, Baron Islington, the Governor of the Dominion of New Zealand, do hereby proclaim the land described in the Schedule hereto as set apart for selection.

**SCHEDULE.**

TARANAKI LAND DISTRICT.

*Whakaihūwaka Block (6,912 Acres).*

Area.	Section No.	Block No.	Situated in the Survey District of	Shown on Plan marked	Edged on Plan
Acres. 1,740	1	XVI	Taurakawa..	L. 4398/4	Red.
747	1	IV	Kapara ..	"	"
382	2	"	" ..	"	"
537	3	"	" ..	"	"
353	4	"	" ..	"	"
460	5	"	" ..	"	"
1,055	1	I	Tua ..	"	"
1,170	2	"	" ..	"	"
488	3	"	" ..	"	"

As the same is delineated upon the plan marked as above mentioned, deposited in the Head Office, Department of Lands, at Wellington, and thereon coloured as above noted.

Given under the hand of His Excellency the Right Honourable John Poynder Dickson-Poynder, Baron Islington, Governor and Commander-in-Chief in and over His Majesty's Dominion of New Zealand and its Dependencies; and issued under the Seal of the said Dominion, at the Government House, at Wellington, this eleventh day of November, in the year of our Lord one thousand nine hundred and eleven.

J. CARROLL,  
For Minister of Lands.

GOD SAVE THE KING!

*Allocating Land reserved and taken for a Railway to the Purposes of a Road at Te Horo, in the County of Horowhenua.*

(L.S.) ISLINGTON, Governor.

**A PROCLAMATION.**

WHEREAS the land mentioned in the Schedule hereto forms part of land taken for the purposes of the Wellington and Manawatu Railway, and it is considered desirable to allocate such land to the purposes of a road:

And whereas it has been certified by the Minister of Railways that such land is not required for railway purposes: And whereas such land is situated in the County of Horowhenua, the local authority of which has assented to the issue of this Proclamation:

And whereas His Excellency the Governor is of opinion that the said local authority can conveniently construct and maintain the said road:

Now, therefore, I, John Poynder Dickson-Poynder, Baron Islington, the Governor of the Dominion of New Zealand, in exercise and pursuance of the powers and authorities vested in me by section one hundred and ninety-seven of the Public Works Act, 1908, and of every other power and authority in anywise enabling me in this behalf, do hereby proclaim and declare that the land described in the Schedule hereto shall, upon the publication hereof in the *New Zealand Gazette*, become a road, and that the said road shall be under the control of the Horowhenua County Council, and shall be maintained by the said Council in like manner as other public highways are controlled and maintained by the said Council.

**SCHEDULE.**

ALL those two parcels of land in the Wellington Land District, containing in the aggregate 30·8 perches, more or less, being portions of railway land at Te Horo, on the Wellington-New Plymouth Railway, and being portions of Ngakaroro 1A No. 6, situated in Block II, Kaitawa Survey District; as the said two parcels of land are more particularly delineated on the plan marked W.R. 18994, deposited in the office of the Minister of Railways, at Wellington, in the Provincial District of Wellington, and thereon coloured purple.

Given under the hand of His Excellency the Right Honourable John Poynder Dickson-Poynder, Baron Islington, Governor and Commander-in-Chief in and over His Majesty's Dominion of New Zealand and its Dependencies; and issued under the Seal of the said Dominion, at the Government House, at Wellington, this ninth day of November, in the year of our Lord one thousand nine hundred and eleven.

J. A. MILLAR,  
Minister of Railways.

GOD SAVE THE KING!

*Land proclaimed as a Road, and Road closed, in Block VI, Karioi Survey District, Raglan County.*

(L.S.) ISLINGTON, Governor.

**A PROCLAMATION.**

IN pursuance and in exercise of the powers conferred by section eleven of the Land Act, 1908, I, John Poynder Dickson-Poynder, Baron Islington, the Governor of the Dominion of New Zealand, do hereby, with the consents of the owners and mortgagees of the land described in the First Schedule hereto, and of the Raglan County Council, being the local authority in whose district the said land is

situated, proclaim as a road the land in Karioi Survey District described in the First Schedule hereto; and also do hereby, with the like consents as aforesaid, proclaim as closed the road described in the Second Schedule hereto, which is not required by reason of the road described in the First Schedule.

**FIRST SCHEDULE.**

**LAND PROCLAIMED AS A ROAD.**

Approximate Area of each of the Parcels of Land proclaimed as a Road.	Being Portion of Section No.	Situated in Block	Situated in Survey District of	Shown on Plan	Coloured on Plan
A. R. P. 0 0 25·8	36	VI	Karioi ..	P.W.D. 30532	Purple.
1 2 23·8	50 (15265, blue)	"	" ..	Ditto ..	Pink.

**SECOND SCHEDULE.**

**ROAD CLOSED.**

Approximate Area of each of the Pieces of Road hereby closed.	Passing through	Situated in Block	Situated in Survey District of	Shown on Plan	Coloured on Plan
A. R. P. 0 2 16·71	36	VI	Karioi ..	P.W.D. 30532	Green.
1 0 37·8	50 (15265, blue)	"	" ..	Ditto ..	"

All in the Auckland Land District; as the same are more particularly delineated on the plan marked and coloured as above mentioned, and deposited in the office of the Minister of Public Works, at Wellington, in the Wellington Provincial District.

Given under the hand of His Excellency the Right Honourable John Poynder Dickson-Poynder, Baron Islington, Governor and Commander-in-Chief in and over His Majesty's Dominion of New Zealand and its Dependencies; and issued under the Seal of the said Dominion, at the Government House, at Wellington, this thirteenth day of November, in the year of our Lord one thousand nine hundred and eleven.

R. MCKENZIE,  
Minister of Public Works.

GOD SAVE THE KING!

*Land proclaimed as a Road in Block XIV, Cambridge Survey District, Matamata County.*

(L.S.) ISLINGTON, Governor.

**A PROCLAMATION.**

IN pursuance and in exercise of the powers conferred by section eleven of the Land Act, 1908, I, John Poynder Dickson-Poynder, Baron Islington, the Governor of the Dominion of New Zealand, do hereby, with the consents of the owner and mortgagees of the land described in the Schedule hereto, and of the Matamata County Council, being the local authority in whose district the said land is situated, proclaim as a road the land in Cambridge Survey District described in the Schedule hereto.

**SCHEDULE.**

Approximate Area of the Parcel of Land proclaimed as a Road.	Being Portion of	Situated in Block	Situated in Survey District of	Shown on Plan	Coloured on Plan
A. R. P. 1 0 22	Lot 2 of part Maungatautari No. 1 Block (15974, blue)	XIV	Cambridge	P.W.D. 30288	Red.

In the Auckland Land District; as the same is more particularly delineated on the plan marked and coloured as above mentioned, and deposited in the office of the Minister of Public Works, at Wellington, in the Wellington Provincial District.

Given under the hand of His Excellency the Right Honourable John Poynder Dickson-Poynder, Baron Islington, Governor and Commander-in-Chief in and over His Majesty's Dominion of New Zealand and its Dependencies; and issued under the Seal of the said Dominion, at the Government House, at Wellington, this thirteenth day of November, in the year of our Lord one thousand nine hundred and eleven.

R. MCKENZIE,  
Minister of Public Works.

GOD SAVE THE KING!

Land taken for the Tokatoka Post-office in Block VI, Tokatoka Survey District.

(L.S.) ISLINGTON, Governor.

A PROCLAMATION.

WHEREAS the land described in the Schedule hereto is required to be taken, under the Public Works Act, 1908, for a certain work, to wit, for the purposes of the Tokatoka Post-office in Block VI, Tokatoka Survey District:

And whereas an agreement has been entered into, in terms of section twenty-seven of the said Act, to take such land for the public work hereinafter set forth:

And whereas a plan has been prepared, and the Minister has recommended the Governor to issue a Proclamation taking the land as required by the said Act:

Now, therefore, I, John Poynder Dickson-Poynder, Baron Islington, the Governor of the Dominion of New Zealand, in pursuance and in exercise of the powers and authorities vested in me by the Public Works Act, 1908, and of every other power and authority in anywise enabling me in this behalf, and being satisfied of the sufficiency of the agreement hereinbefore referred to, do hereby proclaim and declare that the land described in the Schedule hereto is hereby taken for the purposes of the Tokatoka Post-office; and I do also hereby declare that this Proclamation shall take effect on and after the twenty-ninth day of November, one thousand nine hundred and eleven.

SCHEDULE.

Approximate Area of the Parcel of Land taken.	Being Portion of	Situated in Block	Situated in Survey District of	Shown on Plan	Coloured on Plan
A. R. P. 0 1 0	Section 63, Township of Tokatoka	VI	Tokatoka	P.W.D. 30039	Red.

In the Auckland Land District; as the same is more particularly delineated on the plan marked and coloured as above mentioned, and deposited in the office of the Minister of Public Works, at Wellington, in the Wellington Provincial District.

Given under the hand of His Excellency the Right Honourable John Poynder Dickson-Poynder, Baron Islington, Governor and Commander-in-Chief in and over His Majesty's Dominion of New Zealand and its Dependencies; and issued under the Seal of the said Dominion, at the Government House, at Wellington, this thirteenth day of November, in the year of our Lord one thousand nine hundred and eleven.

R. MCKENZIE,  
Minister of Public Works.

GOD SAVE THE KING!

*Opossums to be deemed Imported Game.*

ISLINGTON, Governor.

IN pursuance and exercise of the powers and authorities vested in me by the Animals Protection Act, 1908, I, John Poynder Dickson-Poynder, Baron Islington, the Governor of the Dominion of New Zealand, do hereby declare that, from and after the date hereof, opossums of every variety shall come within the provisions of the said Act relating to imported game as fully and effectually as if they had been included in the Second Schedule thereto.

As witness the hand of His Excellency the Governor, this tenth day of November, one thousand nine hundred and eleven.

J. CARROLL,  
For Minister of Internal Affairs.

Opening Lands in Southland Land District for Selection on Renewable Lease.

ISLINGTON, Governor.

IN pursuance and exercise of the powers and authorities conferred upon me by the Land Act, 1908, I, John Poynder Dickson-Poynder, Baron Islington, the Governor of the Dominion of New Zealand, do hereby declare that the lands described in the Schedule hereto shall be open for selection on renewable lease on Wednesday, the twenty-first day of February, one thousand nine hundred and twelve, at the rentals mentioned in the said Schedule; and I do also declare that the said lands shall be leased under and subject to section one hundred and thirty-five of the said Act, as they contain, or are supposed to contain, metal, mineral, or valuable stone.

SCHEDULE.

SOUTHLAND LAND DISTRICT.—WALLACE COUNTY.—LONGWOOD SURVEY DISTRICT.—OTAGO MINING DISTRICT.

*Second-class Land.*

Section.	Block.	Area.	Capital Value.	Half-yearly Rental.
5	XII	A. R. P. 246 0 0	£ s. d. 160 0 0	£ s. d. 3 4 0
6	"	203 3 0	160 0 0	3 4 0
7	"	227 2 0	120 0 0	2 8 0

Altitude, 300 ft. to 700 ft. above sea-level. Broken forest land; all milling-timber has been cut out by sawmills. Clay formation, well watered. Situated three miles and a half to four miles from Orepuki Railway-station.

As witness the hand of His Excellency the Governor, this seventh day of November, one thousand nine hundred and eleven.

J. G. WARD,  
Minister of Lands.

Opening Lands in Nelson Land District for Selection on Renewable Lease.

ISLINGTON, Governor.

IN pursuance and exercise of the powers and authorities conferred upon me by the Land Act, 1908, I, John Poynder Dickson-Poynder, Baron Islington, the Governor of the Dominion of New Zealand, do hereby declare that the lands described in the Schedule hereto shall be open for selection on renewable lease on Wednesday, the tenth day of January, one thousand nine hundred and twelve, at the rentals mentioned in the said Schedule; and I do also declare that the said lands shall be leased under and subject to section one hundred and thirty-five of the said Act, as they contain, or are supposed to contain, metal, mineral, or valuable stone.

**SCHEDULE.**  
NELSON LAND DISTRICT.  
*Second-class Land.*

Section.	Block.	Area.	Capital Value.	Half-yearly Rental.
----------	--------	-------	----------------	---------------------

WAIMEA COUNTY.—KAITERITERI SURVEY DISTRICT.

		A. R. P.	£ s. d.	£ s. d.
2	X	360 1 20	190 0 0	3 16 0
1A, 95	VIII			

All hills, about 60 acres bush, principally birch, remainder fern and manuka scrub. Inferior soil, sandstone formation; well watered. Access by Sandy Bay Road, a mile and a half from Riwaka Post-office.

6 and 7	VIII	282 2 10	145 0 0	2 18 0
---------	------	----------	---------	--------

All hills, covered with fern and dry timber, fires having been through it. Inferior soil, sandstone formation; indifferently watered. Access from Riwaka, two miles by Sandy Bay Road and half a mile by unformed road.

4	VIII	375 3 18	190 0 0	3 16 0
86	XII			

All hills, covered with fern and dry timber, fires having been through it. Inferior soil, on sandstone formation; indifferently watered. Access from Riwaka, two miles by Sandy Bay Road and a mile and a quarter by unformed road.

MURCHISON COUNTY.—MARUTA SURVEY DISTRICT.

4	IV	540 2 9	325 0 0	6 10 0
---	----	---------	---------	--------

The whole section is well adapted for pastoral purposes; the land ranges from flats to low hills. Good soil, on a limestone and sandstone formation; well watered. Originally all bush, but fires have gone through the greater portion of the section. Accessible by good dray-road from Murchison, about ten miles and a half.

7	VIII	463 0 0	235 0 0	4 14 0
---	------	---------	---------	--------

All bush, mostly brown and silver birch, with thick underscrub; the land ranges from undulating to steep hills. The soil is of good quality, well adapted for pastoral purposes, on granite and sandstone formation; well watered. Accessible by good dray-road from Murchison, which is on the opposite side of the river (fifteen miles).

9	VIII	979 0 0	490 0 0	9 16 0
---	------	---------	---------	--------

All bush, mostly brown and silver birch, with thick underscrub. The land, which is of good quality, ranges from flats to steep hills, on limestone and sandstone formation; well watered; and well suited for pastoral purposes. Accessible by good dray-road from Murchison, about fifteen miles.

MURCHISON COUNTY.—BURNETT SURVEY DISTRICT.

8	III	657 0 0	365 0 0	7 6 0
---	-----	---------	---------	-------

Good pastoral land, ranging from low river-flats to fairly high hills. The soil is good on the flats, and varies from good to inferior on the hills; granite and sandstone formation; covered with heavy timber, mostly brown and silver birch; well watered. Accessible from Murchison, eighteen miles by good dray-road and eight miles by bridle-track.

9	III	756 0 0	455 0 0	9 2 0
---	-----	---------	---------	-------

Good pastoral land, on granite and sandstone formation; covered with bush, principally brown and silver birch. The soil varies from good on the low river-flats to inferior on the spurs and hill tops; well watered. Accessible from Murchison, eighteen miles by good dray-road and nine miles by bridle-track.

3	IV	1,000 0 0	500 0 0	10 0 0
---	----	-----------	---------	--------

All undulating and hilly country; well watered; and covered with bush, mostly brown and silver birch. Fair soil, on granite and sandstone formation; suitable for pastoral purposes. Accessible from Murchison by good dray-road (eighteen miles) and eight miles track.

As witness the hand of His Excellency the Governor, this seventh day of November, one thousand nine hundred and eleven.

J. G. WARD,  
Minister of Lands.

*Opening National Endowment Lands in Nelson Land District for Selection.*

ISLINGTON, Governor.

IN pursuance and exercise of the powers and authorities conferred upon me by the Land Act, 1908, I, John Poynder Dickson-Poynder, Baron Islington, the Governor of the Dominion of New Zealand, do hereby declare that the

national endowment lands described in the Schedule hereto shall be open for selection on renewable lease on Wednesday, the tenth day of January, one thousand nine hundred and twelve, at the rentals mentioned in the said Schedule; and I do also declare that the said lands shall be leased under and subject to the provisions of the said Act.

**SCHEDULE.**

NELSON LAND DISTRICT.  
*Second-class Land.*

Section.	Block.	Area.	Capital Value.	Half-yearly Rental.
----------	--------	-------	----------------	---------------------

BULLER COUNTY.—OPARARA SURVEY DISTRICT.

		A. R. P.	£ s. d.	£ s. d.
2	X	500 1 34	380 0 0	7 12 0
32	XV			

Situated on the north bank of the River Karamea, about seven miles and a half from Karamea by the road along the south bank of the river. Very rich soil on the terraces for about 20 to 40 chains from the frontage, inferior soil on the higher ground. Covered with heavy bush, mostly black-birch, with a little rimu.

INANGAHUA COUNTY.—INANGAHUA SURVEY DISTRICT.

12, 15, and 17	XII	144 0 0	180 0 0	3 12 0
----------------	-----	---------	---------	--------

Weighted with £236 15s. for improvements, consisting of a house 28 ft. by 22 ft., fencing, clearing, and grassing, &c.

Undulating land, ranging from 25 ft. to 40 ft. above the river. 20 acres cleared and grassed; balance heavy bush, brown-birch, white-birch, and silver-birch, with a considerable amount of white-pine at the back. The front of these sections is fairly dry; but the back is somewhat wet, and heavily moss-grown in places. Well watered by Blackwater Creek. Accessible by main coach-road, fourteen miles from Reefton.

As witness the hand of His Excellency the Governor, this seventh day of November, one thousand nine hundred and eleven.

J. G. WARD,  
Minister of Lands.

*Notifying Land in Taranaki Land District for Sale by Public Auction.*

ISLINGTON, Governor.

IN pursuance of the powers and authorities conferred upon me by the one-hundred-and-twenty-sixth section of the Land Act, 1908, I, John Poynder Dickson-Poynder, Baron Islington, the Governor of the Dominion of New Zealand, do hereby appoint Wednesday the twentieth day of December, one thousand nine hundred and eleven, as the time at which the land enumerated in the Schedule hereto shall be sold by public auction; and I do hereby fix the price at which the said land shall be sold as that mentioned in the said Schedule hereto.

**SCHEDULE.**

TARANAKI LAND DISTRICT.—OHURA COUNTY.—OHURA SURVEY DISTRICT.  
*Rural Land.*

Section.	Block.	Area.	Upset Price.
----------	--------	-------	--------------

		A. R. P.	£ s. d.
3	XV	358 0 0	1,408 10 0

The improvements, which are included in the upset price, consist of the following: 55 acres felled only, £68 15s.; 105 acres felled and grassed, £52 10s.; 5 chains wire netting on posts, 12s. 6d.; 101 chains fencing, £84 7s.; 58 chains fencing-wire on posts at homestead, £4 7s.; house, £90; whare, £15; pataka, £5: total, £320 11s. 6d.

The section is situated on the Aorangi Road, about one mile and three-quarters by good horse-track from Aukopae Landing, Wanganui River, which is about sixteen miles from Taumarunui by the river. There is also access from Taumarunui by a good horse-track, about twenty miles.

The section comprises flat, easy sloping, and rather steep country. The soil is of good quality generally, on papa formation. The forest is varied, ranging from fern and manuka to heavy bush consisting of rata, tawa, totara, rimu, miro, matai, white-pine, hinau, tawhero, &c., with a fairly dense undergrowth of supplejack, raureka, punga,

and other soft woods and ferns. The section is well watered. Elevation ranges from 600 ft. to 1,200 ft. above sea-level.

As witness the hand of His Excellency the Governor, this fifteenth day of November, one thousand nine hundred and eleven.

D. BUDDO,  
For Minister of Lands.

*Land temporarily reserved as a Site for a Public Hall and Library in Block VIII, Maniototo Survey District, in the Otago Land District.*

ISLINGTON, Governor.

WHEREAS by the three-hundred-and-twenty-first section of the Land Act, 1908, it is enacted that the Governor may from time to time, either by general or particular description, and whether the same has been surveyed or not, reserve from sale temporarily, notwithstanding that the same may be then held under pastoral license, any Crown lands which in his opinion are required for any of the purposes in the said section mentioned:

Now, therefore, I, John Poynder Dickson-Poynder, Baron Islington, the Governor of the Dominion of New Zealand, in pursuance and exercise of the powers and authorities vested in me by the said Act, do hereby temporarily reserve from sale the land in the Otago Land District described in the Schedule hereunder written, as a site for a public hall and library.

SCHEDULE.

ALL that area in the Otago Land District, containing by admeasurement 1 acre, more or less, being Section No. 20, Block VIII, Maniototo Survey District. Bounded towards the north-west by Crown lands, 299.1 links; towards the south-east by part Section No. 1 of said block, 732.5 links; and towards the south-west by a public road, 668.7 links: be all the aforesaid linkages more or less: as the same is delineated on the plan marked L. 1911/1470, deposited in the Head Office, Department of Lands, at Wellington, and thereon bordered red.

As witness the hand of His Excellency the Governor, this tenth day of November, one thousand nine hundred and eleven.

J. CARROLL,  
For Minister of Lands.

*Land temporarily reserved for Gravel Purposes in Block XIII, Huangarua Survey District, Wellington Land District.*

ISLINGTON, Governor.

WHEREAS by the three-hundred-and-twenty-first section of the Land Act, 1908, it is enacted that the Governor may from time to time, either by general or particular description, and whether the same has been surveyed or not, reserve from sale temporarily, notwithstanding that the same may be then held under pastoral license, any Crown lands which in his opinion are required for any of the purposes in the said section mentioned:

And whereas by the sixty-ninth section of the Land for Settlements Act, 1908, it is further provided that the Governor may from time to time, as he thinks fit, set aside reserves for any specified public purpose out of land acquired under the last-mentioned Act, provided that no land so acquired shall be set aside for endowments:

Now, therefore, I, John Poynder Dickson-Poynder, Baron Islington, the Governor of the Dominion of New Zealand, in pursuance and exercise of the powers and authorities vested in me by the Acts aforesaid, do hereby temporarily reserve from sale the land in the Wellington Land District described in the Schedule hereunder written, for gravel purposes.

SCHEDULE.

ALL that area in the Wellington Land District, containing by admeasurement 1 acre, more or less, being Section No. 8A, Block XIII, Huangarua Survey District. Bounded towards the south-west, north-west, and north-east by Section No. 8 of said block, a distance of 316.2 links in each case, and towards the south-east by Awhea Road, 316.2 links; be all the aforesaid linkages more or less; as the same is delineated on the plan marked L. 1911/1580, deposited in the Head Office, Department of Lands, at Wellington, and thereon bordered red.

As witness the hand of His Excellency the Governor, this tenth day of November, one thousand nine hundred and eleven.

J. CARROLL,  
For Minister of Lands.

*Lands temporarily reserved for Purposes of Public Recreation in the Town of Hawksbury, Otago Land District.*

ISLINGTON, Governor.

WHEREAS by the three-hundred-and-twenty-first section of the Land Act, 1908, it is enacted that the Governor may from time to time, either by general or particular description, and whether the same has been surveyed or not, reserve from sale temporarily, notwithstanding that the same may be then held under pastoral license, any Crown lands which in his opinion are required for any of the purposes in the said section mentioned:

Now, therefore, I, John Poynder Dickson-Poynder, Baron Islington, the Governor of the Dominion of New Zealand, in pursuance and exercise of the powers and authorities conferred upon me by the said Act, do hereby temporarily reserve from sale the lands in the Otago Land District described in the Schedule hereunder written, for purposes of public recreation.

SCHEDULE.

ALL that area in the Otago Land District, containing by admeasurement 1 acre 1 rood, more or less, being Section 6, Block XXXIII, Town of Hawksbury. Bounded towards the north by Perth Street, 200 links; towards the south-east by Sections 1 and 5, Block XXXIII, aforesaid town, 538 links; towards the south by Inverary Street, 375 links; and towards the north-west by the Hawksbury Lagoon, 625 links: be all the aforesaid linkages more or less.

Also all that area in the Otago Land District, containing by admeasurement 6 acres 3 roods, more or less, being Section 1, Block LXXVI, Town of Hawksbury. Bounded towards the north by Inverary Street, 300 links; towards the east by Sections 1 and 9, Block XXXVIII, aforesaid town, 500 links; towards the south by Rothesay Street, 100 links; again towards the east by the abutment of said street and by Section 1, Block XLIV, 350 links; again towards the south by Section 12 of Block XLIV, 50 links; towards the south-east by said Section 12, 269 links; again towards the south by Dumbarton Street, 50 links; again towards the east by the abutment of said street and by Sections 1 and 15, Block L, and by the abutment of Stirling Street, 700 links; again towards the north by said street, 100 links; again towards the east by Section 1, Block LII, 250 links; again towards the north by Sections 1, 2, 3, and 4 of Block LII, 400 links; again towards the east by part of Section 7 and Sections 8 and 9 of Block LII, 250 links; again towards the north by Section 9 of said block and by the abutment of Nairn Street, 350 links; towards the west by said street, 100 links; again towards the north by Section 1, Block LIII, 250 links; again towards the west by Section 1 and part of 2 of Block LIII, 150 links; again towards the north by Section 5 of Block LIII, 100 links; towards the north-west by Sections 6 and 7 of last-mentioned block, 472 links; again towards the north by Stirling Street, 200 links; all of the aforesaid town; and towards the south and south-west generally by Hawksbury Lagoon, 4700 links: be all the aforesaid linkages more or less.

Also all that area in the Otago Land District, containing by admeasurement 4 acres 1 rood, more or less, being Section 10, Block LIV, Town of Hawksbury. Bounded towards the north-west by Section 1, Block LIV, 320 links, aforesaid town; towards the west by part of Section 2, 75 links; towards the north by Sections 4, 5, and 6, 600 links; towards the east by part of Section 8 and Section 9, 175 links; again towards the north by said Section 9, 250 links, all of aforesaid block; again towards the east by Edinburgh Street, 800 links; towards the south by Leith Street, 1150 links; again towards the north-west and towards the south-east generally by Hawksbury Lagoon, 2450 links; and again towards the west by Cromarty Street, 125 links: be all the aforesaid linkages more or less.

Also all that area in the Otago Land District, containing by admeasurement 1 acre 2 roods, more or less, being Section 1, Block LXXV, Town of Hawksbury. Bounded towards the east by Inverness Street, 125 links; towards the south-east by Sections 1 and 2, Block LVIII, 550 links; towards the south by Haddington Street, 50 links; again towards the east by the abutment of said street and by Section 1, Block LXIII, 350 links; again towards the south by Section 10 of Block LXIII, 100 links; again towards the south-east by Section 11 of Block LXIII, 320 links; towards the west by a street, 250 links; and towards the north-west by Hawksbury Lagoon 1175 links: be all the aforesaid linkages more or less.

Also all that area in the Otago Land District, containing by admeasurement 1 rood, more or less, being Section 8, Block LXVIII, Town of Hawksbury. Bounded towards the north-east by Section 1, Block LXVIII, 320 links; towards the south by part of Section 1, Block LXXIV, all of aforesaid town, 200 links; and towards the west by a street, 250 links: be all the aforesaid linkages more or less.

As the same are delineated on the plan marked L. 1178/40, deposited in the Head Office, Department of Lands, at Wellington, and thereon bordered red.

As witness the hand of His Excellency the Governor, this tenth day of November, one thousand nine hundred and eleven.

J. CARROLL,  
For Minister of Lands.

*Appointing Commissioners to classify Pastoral Runs in Otago Land District.*

ISLINGTON, Governor.

IN exercise and pursuance of the powers and authorities vested in me by the two-hundred-and-twenty-fifth section of the Land Act, 1908, I, John Poynder Dickson-Poynder, Baron Islington, the Governor of the Dominion of New Zealand, do hereby appoint

ERNEST HERBERT WILMOT,  
CRAWFORD ANDERSON, and  
PATRICK KINNEY

Commissioners to classify and report to me upon the rural lands in Otago Land District known as Runs Nos. 464, 328A, 217B, 72 and 72A, 17H, and Sections 1, Block X, and 3, Block XI, Domett Survey District, Sections 1, Block X, and 2, Block XIII, Kyeburn Survey District, and 2, Block I, Kakanui Survey District; Runs 458 and 468, 346A, 346C, and Sections 9 and 11 to 17, Block III, Dart Survey District; Sections 76 and 77, Block IV, Table Hill Survey District; Run 11A; Sections 2 to 4, 6 and 7, Block III, and 1 and 2, Block VI, Lower Hawea Survey District, and Section 3, Block V, Lower Wanaka Survey District; and Museum Reserve (Lamb Hill), as provided by section two hundred and twenty-five of the Land Act, 1908.

As witness the hand of His Excellency the Governor, this tenth day of November, one thousand nine hundred and eleven.

J. CARROLL,  
For Minister of Lands.

*Native Interpreters appointed.*

Native Department,  
Wellington, 10th November, 1911.

HIS Excellency the Governor has been pleased to appoint

JAMES PAUMEA FERRIS, of Gisborne, and  
HENARE POANANGA, of Wellington,

to act as licensed Native Interpreters of the First Grade; and

HONE TE PAU MARIU, of Mananui, and  
JAMES BRAZLEY, of Houhora North,

to act as licensed Native Interpreters of the Second Grade, under the provisions of the Native Land Act, 1909, and the regulations made thereunder.

J. CARROLL,  
Native Minister.

*Member of Otorohanga Native Township Council appointed.*

Native Department,  
Wellington, 11th November, 1911.

HIS Excellency the Governor has been pleased to appoint

WILLIAM VICARY, Esq., of Otorohanga, to be a member of the Otorohanga Native Township Council, vice Frederick Mace, Esq., resigned.

J. CARROLL,  
Native Minister.

*Returning Officer under Section 46 of the Licensing Amendment Act, 1910, appointed.*

Native Department,  
Wellington, 11th November, 1911.

HIS Excellency the Governor has been pleased to appoint

CHARLES WOODHOUSE GRACE, Esq., of Kaikohe, to be Returning Officer for every poll to be taken in the Wairoa Maori Council District, said district having been proclaimed under section 46 of the Licensing Amendment Act, 1910.

J. CARROLL,  
Native Minister.

*Returning Officer under Section 46 of the Licensing Amendment Act, 1910, appointed.*

Native Department,  
Wellington, 11th November, 1911.

HIS Excellency the Governor has been pleased to appoint

HAROLD CARR, Esq., of Gisborne,

to be Returning Officer for every poll to be taken in the Horouta and Arawa Maori Council Districts, said districts having been proclaimed under section 46 of the Licensing Amendment Act, 1910.

J. CARROLL,  
Native Minister.

*Clerical Cadet appointed.*

Public Works Department,  
Wellington, 13th November, 1911.

HIS Excellency the Governor has been pleased to appoint

FREDERICK KEITH CHIPMAN

to be a Clerical Cadet in the Public Works Department, as from 7th July, 1911.

R. McKENZIE,  
Minister of Public Works.

*Clerical Cadet appointed.*

Public Works Department,  
Wellington, 13th November, 1911.

HIS Excellency the Governor has been pleased to appoint

HORACE GREGORY HEWETT LARKING

to be a Clerical Cadet in the Public Works Department, as from 26th June, 1911.

R. McKENZIE,  
Minister of Public Works.

*Assayer appointed.*

Department of Trade and Customs,  
Wellington, 9th November, 1911.

HIS Excellency the Governor has been pleased to appoint

ISAAC HENRY CORNWALL

to be an Assayer of Gold for the purposes of the Gold Duty Act, 1908.

R. McKENZIE,  
Minister of Customs.

*Appointments, Promotions, Transfers, Resignations, and Retirements of Territorial Force Officers.*

Defence Office,  
Wellington, 9th November, 1911.

HIS Excellency the Governor has been pleased to approve of the appointments, promotions, transfers, resignations, and retirements of the undermentioned Territorial Force Officers:—

*4th (Waikato) Mounted Rifles.*

The undermentioned gentlemen to be 2nd Lieutenants:—  
William Poole Bell, Esq. Dated 16th September, 1911.  
Lance-Corporal George Franklyn Yerex, Supernumerary to the establishment. Dated 2nd October, 1911.  
Lieutenant Frederick Charles Daniell is transferred to the 16th (Waikato) Regiment. Dated 11th October, 1911.

The undermentioned Reserve Officers resign their commissions:—

Lieutenant Henry Francis Edgecumbe. Dated 20th September, 1911.  
Lieutenant Percy Francis Boucher. Dated 28th September, 1911.

*7th (Southland) Mounted Rifles.*

2nd Lieutenant John William Earl resigns his commission. Dated 7th September, 1911.

*12th (Otago) Mounted Rifles.*

The undermentioned 2nd Lieutenants to be Lieutenants:—  
Thomas Graham, vice Keys, resigned. Dated 30th June, 1911.

John Gibbons Blackie, to complete establishment. Dated 5th October, 1911.

*New Zealand Field Artillery.*

2nd Lieutenant Robert Cameron Galbraith is transferred to the New Zealand Post and Telegraph Corps. Dated 5th October, 1911.

*New Zealand Garrison Artillery.*

The undermentioned officers are transferred to the New Zealand Post and Telegraph Corps. Dated 5th October, 1911 :—

Captain Adam Morrison Rattray.  
Lieutenant George Chetwyn Parker.

Lieutenant Maurice Edward Denniston, late Active List (Unattached), is transferred to the Reserve of Officers. Dated 5th October, 1911.

*Corps of New Zealand Engineers.*

Sergeant-major James Findlay Robertson to be 2nd Lieutenant. Dated 13th September, 1911.

2nd Lieutenant Robert Newton Vanes to be Lieutenant. Dated 5th October, 1911.

Lieutenant Harold Lincoln Slyfield is transferred to the New Zealand Post and Telegraph Corps. Dated 5th October, 1911.

*3rd (Auckland) Regiment ("Countess of Ranfurly's Own").*

The undermentioned to be 2nd Lieutenants :—

Lance-Sergeant James Blackwood Neely. Dated 30th June, 1911.

Lance-Corporal James Grierson Hatrick. Dated 30th June, 1911.

Edwin Gordon Fraser, Esq. Dated 27th September, 1911.

Lieutenant Valentine Dunne is transferred to the New Zealand Post and Telegraph Corps. Dated 5th October, 1911.

*5th Regiment (Wellington Rifles).*

Lieutenant John Robert Thomas Slipper is transferred to the 7th Regiment (Wellington West Coast Rifles). Dated 11th October, 1911.

2nd Lieutenant John Richard Hughes, from the 7th Regiment (Wellington West Coast Rifles), to be 2nd Lieutenant. Dated 11th October, 1911.

*6th (Hauraki) Regiment.*

Colvin Stewart Algie, Esq., to be 2nd Lieutenant. Dated 21st September, 1911.

The undermentioned officers are transferred to the New Zealand Post and Telegraph Corps. Dated 5th October, 1911 :—

Captain Henry Joseph Pearse.  
Lieutenant Frederick Michael Syms.

Captain Thomas White Sommerville, Reserve of Officers, resigns his commission. Dated 15th September, 1911.

*7th Regiment (Wellington West Coast) Rifles.*

Lieutenant John Robert Thomas Slipper, from the 5th Regiment (Wellington Rifles), to be Lieutenant. Dated 11th October, 1911.

2nd Lieutenant John Richard Hughes is transferred to the 5th Regiment (Wellington Rifles). Dated 11th October, 1911.

*15th (North Auckland) Regiment.*

Cyril Leonard Fleming to be 2nd Lieutenant. Dated 14th September, 1911.

*16th (Waikato) Regiment.*

Lieutenant-Colonel George Barclay, v.d., is transferred to the New Zealand Railways Corps. Dated 5th October, 1911.

Lieutenant Frederick Charles Daniell, from the 4th (Waikato) Mounted Rifles, to be Lieutenant and Quartermaster. Dated 11th October, 1911.

*New Zealand Medical Corps.*

Lieutenant Gerald Warren Russell resigns his commission. Dated 21st September, 1911.

The undermentioned Reserve Officers resign their commissions :—

Captain Albert Harding Porter. Dated 29th August, 1911.  
Captain Stuart Bathgate Reid. Dated 16th September, 1911.

Captain George Edward Anson, M.D., Reserve of Officers, retires under the provisions of paragraph 119, General Regulations, 1911. Dated 23rd September, 1911.

*New Zealand Chaplains Department.*

The undermentioned are appointed Chaplains to the Forces, 4th Class :—

The Reverend Himepiri Munro. Dated 18th September, 1911.

The Reverend Walter Tuahangata Fraser. Dated 18th September, 1911.

The Reverend Ratema Te Awekotuku. Dated 28th September, 1911.

The Reverend Edward Salmon Wayne. Dated 28th September, 1911.

The Reverend Wainohu Henare Wepiha. Dated 30th September, 1911.

*New Zealand Railway Corps.*

Thomas Ronayne, Esq., to be Director of Railways, with the rank of Colonel. Dated 5th October, 1911.

Lieutenant-Colonel George Barclay, v.d., from 16th (Waikato) Regiment, to be Lieutenant-Colonel, to command a battalion. Dated 5th October, 1911.

Richard William McVilly, Esq., to be Staff Officer to Director of Railways, with the rank of Lieutenant-Colonel. Dated 5th October, 1911.

Hunter Macandrew, Esq., to be Lieutenant-colonel, to command a battalion. Dated 5th October, 1911.

*New Zealand Post and Telegraph Corps.*

David Robertson, Esq., to be Director of Post and Telegraph Services, with the rank of Colonel. Dated 5th October, 1911.

Lieutenant-Colonel William Russell Morris, Retired List, to be Staff Officer to Director of Post and Telegraph Services, with the rank of Lieutenant-Colonel. Dated 5th October, 1911.

Captain Henry Joseph Pearse, 6th (Hauraki) Regiment, to be Captain. Dated 5th October, 1911.

Captain Adam Morrison Rattray, New Zealand Garrison Artillery, to be Captain. Dated 5th October, 1911.

Lieutenant Frederick Michael Syms, 6th (Hauraki) Regiment, to be Lieutenant. Dated 5th October, 1911.

Lieutenant Harold Lincoln Slyfield, New Zealand Engineers, to be Lieutenant. Dated 5th October, 1911.

Lieutenant George Chetwyn Parker, New Zealand Garrison Artillery, to be Lieutenant. Dated 5th October, 1911.

Lieutenant Valentine Dunne, 3rd (Auckland) Regiment ("Countess of Ranfurly's Own"), to be Lieutenant. Dated 5th October, 1911.

2nd Lieutenant Robert Cameron Galbraith, New Zealand Field Artillery, to be 2nd Lieutenant. Dated 5th October, 1911.

*Unattached List.*

The undermentioned Defence Cadet Officers are transferred for service with the Senior Cadets, under the provisions of paragraph 88 (b), General Regulations, 1911 :—

Captain Thomas John Hussey. Dated 5th December, 1906.  
Lieutenant Henry Dolphus McHugh. Dated 7th September, 1909.

„ Phelan Hansen. Dated 5th October, 1910.

The undermentioned gentleman is appointed for service with the Senior Cadets, under the provisions of paragraph 88 (b), General Regulations, 1911 :—

George Xavier Bell Poppelwell, Esq., to be 2nd Lieutenant. Dated 5th October, 1911.

The seniority of the undermentioned officers transferred for service with the Senior Cadets is as now shown, and not as stated in the *New Zealand Gazette*s dated 7th and 21st September, 1911 :—

Captain Malcolm Kennedy McCulloch. Dated 7th December, 1904.

„ William Henry Moyes. Dated 4th March, 1908.

„ Frank Farthing. Dated 4th March, 1908.

Lieutenant William Hudson Scoon. Dated 4th June, 1911.

„ William Allan Armour. Dated 5th December, 1906.

„ John Bartholomew Callan. Dated 2nd September, 1908.

„ Charles Henry McKay. Dated 7th December, 1910.

„ Frederick Johnston. Dated 16th May, 1911.

„ Richard Edward Joseph Martin. Dated 16th May, 1911.

*Memoranda.*

Lieutenant John Frederick Rockstrow, late Active List (Unattached), retires under the provisions of paragraph 118, General Regulations, 1911, with the honorary rank of Captain, and with permission to wear the prescribed uniform. Dated 5th October, 1911.

Captain Alexander McHardy, late Active List (Unattached), retires under the provisions of paragraph 119, General Regulations, 1911. Dated 11th October, 1911.

J. G. WARD,  
Minister of Defence.

*Resignation of Trustees of the Napier Drill-shed Reserve.*

Defence Office,  
Wellington, 9th November, 1911.

**H**IS Excellency the Governor has been pleased to accept, under Part V of the Defence Act, 1908, the resignation of

- Lieutenant-Colonel Julius Sandtmann, 9th Mounted Rifles;
- Major John Chicken, v.d., Retired List;
- Captain Frederick George Smith, Retired List;
- Charles Dugald Kennedy, Esq.;
- Robert Donald Douglas McLean, Esq.;
- John Henry Coleman, Esq.,

as Trustees of the Napier Drill-shed Reserve. Date of resignation, 1st October, 1911.

J. G. WARD,  
Minister of Defence.

*Award of the Colonial Auxiliary Forces Officers' Decoration.*

Defence Office,  
Wellington, 9th November, 1911.

**H**IS Excellency the Governor has been pleased to approve of the award of the Colonial Auxiliary Forces Officers' Decoration to

- Lieutenant-Colonel DAVID PRINGLE, 6th (Manawatu) Mounted Rifles,

he having a total rank and commissioned service to 6th October, 1911, entitling him thereto of twenty years three hundred and twenty-seven days.

J. G. WARD,  
Minister of Defence.

*Acceptance of Services of a Defence Rifle Club.*

Defence Office,  
Wellington, 9th November, 1911.

**H**IS Excellency the Governor has been pleased to accept, under section 43, (1) and (2), of the Defence Act, 1909, the services of the undermentioned Defence rifle club:—

*Hauraki No. 1 Defence Rifle Club,*

with headquarters at Waihi, Auckland Military District. Date of acceptance, 30th October, 1911.

J. G. WARD,  
Minister of Defence.

*30th November to be a Holiday in Celebration of St. Andrew's Day.*

Office of the Minister of Internal Affairs,  
Wellington, 11th November, 1911.

**T**HE Government offices throughout New Zealand will be closed on Thursday, 30th November, 1911, in celebration of St. Andrew's Day.

D. BUDDO,  
Minister of Internal Affairs.

*Letters of Naturalization issued.*

Office of the Minister of Internal Affairs,  
Wellington, 14th November, 1911.

**H**IS Excellency the Governor has been pleased to issue Letters of Naturalization, under the Aliens Act, 1908, in favour of the undermentioned persons:—

Name.	Occupation.	Residence.
Hedwig Christine Andersen	Dressmaker ..	Wanganui.
Mijo Antunovich	Gum-digger ..	Waihopo.

Name.	Occupation.	Residence.
Collil Buderwill, otherwise known as Michael Buderwill	Storekeeper ..	Auckland.
Toni Borsevich ..	Gum-digger ..	Awanui.
Julius Bulst ..	Farmer ..	Mangapapa.
Joe Cvjetanov Botica ..	Viticulturist ..	Awanui.
Giovanni Cuomo ..	Mariner ..	Parnell.
Lars Christian Christoffersen ..	Labourer ..	Kaiwaka.
Abraham Cohen ..	General merchant	Balclutha.
Theodor David Davidson	Miner ..	Maungaturoto.
Frederick August Eudri ..	Carpenter ..	Palmerston N.
Richard Eberle ..	Farmer ..	Kaponga.
Mathias Ellison ..	Seaman ..	Wellington.
Silvan Elsener ..	Farmer ..	Kaponga.
Henry Feisst ..	Farm labourer ..	Matamata.
Robert Freeman ..	Jeweller ..	Palmerston N.
Charles Freilich ..	Picture-framer ..	"
Sarah Ann Franco ..	Domestic duties ..	Wadestown, Wellington.
Jure Granich ..	Gum-digger ..	Waihopo.
Mate Grbich ..	" ..	Paerenga.
Ivan Grbich ..	" ..	"
Isaiah Gordon ..	Picture-framer ..	Palmerston N.
Anton Henning Groot-hoff	Labourer ..	Whakataki.
Grgo Grgurinovich ..	Gum-digger ..	Poroti.
Stipan Garelija ..	Labourer ..	Awanui.
Leondre Hasinger ..	Painter ..	Auckland.
Mikko Himainen ..	Seaman ..	"
Josepf Lucas Huwyler	Farmer ..	Whangarei.
Abdo Howley ..	Settler ..	Dunedin South.
Sigfried Hildbrand ..	Farm hand ..	Kaponga.
Charles Johnson ..	Platelayer ..	Hunterville.
George Klarich ..	Labourer ..	Poroti.
Karl Kliem ..	Farmer ..	Puketi.
Fredrick William Klein	Storekeeper ..	Palmerston N.
John Jacob Laine ..	Roadman ..	Inangahua Junction.
Ivan Lendich ..	Gum-digger ..	Mangawai.
John Lindburg ..	Wharf labourer ..	Gisborne.
Jakov Medak ..	Gum-digger ..	Poroti.
Frank Xaver Müller ..	Farm hand ..	Kaponga.
Henry Gavil Mitchell	Fire-brigadesman	Dunedin.
Fritz Patrik Meyer ..	Cook ..	Martinborough.
Gustav Meiers ..	Bootmaker ..	Rothesay.
Moses Mann ..	Hawker ..	Dunedin.
Ivan Matijasevic ..	Gum-digger ..	Poroti.
Lawrence George Nielson	Carpenter ..	Manaia.
John Notter ..	Farm hand ..	Kaponga.
Erik Noren ..	Drainer ..	Dunedin.
Hans Rudolf Olsen ..	Dredge-master ..	Al-xandra South.
Konsta Ojala ..	Carpenter ..	Auckland.
Johann Heinrich Otto	" ..	Maungakaramea.
Sara Gimila Pedersen	Shop-assistant ..	New Plymouth.
Paula Gimila Pedersen	" ..	"
Anders Pedersen ..	Farmer ..	"
Michael Pasquene ..	Labourer ..	Gisborne.
Johan Rauch ..	Mechanic ..	Hawera.
John Ferdinand Scholten	Fisherman ..	Portobello.
William Benedict Scott	Yard foreman ..	Hawera.
Ruton Steiner ..	Farmer ..	Kaponga.
Jure Selak ..	Gum-digger ..	Mangawai.
Joseph Steiner ..	Farmer ..	Kaponga.
John Smith ..	Fisherman ..	Moturoa.
Edmund Spencer ..	Master printer ..	Auckland.
Jacob Schumacher ..	Farmer ..	Kaponga.
Charles Thompson ..	Gum-digger ..	Lake Ohia.
John Trbuhovich ..	Labourer ..	Waiau Pa.
Otto Tiller ..	Farmer ..	Palmerston N.
Grgo Urlic ..	Labourer ..	Lake Ohia.
Albert Uttinger ..	Farmer ..	Kaponga.
Mijo Vujcich ..	Settler ..	Kohukohu.
Ludveg Vendt ..	Labourer ..	Otoroa.
Kati Wakem ..	Domestic duties	Pakakura.
John Wolf ..	Labourer ..	Te Hana.

D. BUDDO,  
Minister of Internal Affairs.



*Special Order made by the Remuera Road Board, County of Eden, making By-laws.*

Office of the Minister of Internal Affairs,  
Wellington, 11th November, 1911.

THE following special order, made by the Remuera Road Board, is published in accordance with the provisions of the Road Boards Act, 1908.

D. BUDDO,  
Minister of Internal Affairs.

REMUERA ROAD BOARD.

*Building By-law relating to Minimum Areas.*

THE Remuera Road Board, in pursuance of the Public Health Act, 1908, and its amendment, the Road Boards Act, 1908, and of every other power (if any) thereunto enabling it, doth hereby make and ordain the following by-law:—

1. In these by-laws, if not inconsistent with the context, the following words and expressions shall have the meaning hereby assigned to them, that is to say,—

“The Board” means the Remuera Road Board;

“The District” means the Remuera Road District;

“New house” shall have the meaning assigned to that term by certain by-laws of the Board made by special order on the 7th day of March, 1910, and confirmed on the 28th day of April, 1910.

Words importing the singular number shall include the plural, words importing the masculine gender shall include the feminine, and words importing a person shall include a company and a corporation.

2. Paragraph (d), clause 2, of the by-laws made by the Board by special order on the 7th day of March, 1910, and confirmed on the 28th day of April, is hereby revoked, and clause 1 hereof and the following clauses substituted in lieu thereof.

3. No person shall within the district erect any new house upon any land, unless such land has—

(a) A frontage of not less than 50 ft. to some public road; and

(b) A mean average depth, measured from the line of abutment upon such road, of not less than 132 ft.

4. Nothing herein contained shall be construed so as to prevent the erection of one new house upon any area which does not conform to the requirements of clause 3 of these by-laws, provided that such area is shown as a separate and distinct area or subdivision on any plan deposited in the Land Transfer or Deeds Registration Office at Auckland before the publication of these by-laws in the *New Zealand Gazette*.

5. It shall not be deemed a breach of these by-laws to erect a new house upon any land situated partly at the back of any other land immediately abutting upon any public road if such first-mentioned land—

(a) Shall not have a frontage of 50 ft., but shall have a frontage of at least 10 ft. to such public road; and

(b) Shall not be less than half an acre in area. And such area shall be computed so as to exclude the whole of any entrance or right-of-way giving access to such back section.

6. In any case where there are two adjoining allotments one of which is situated partly at the back of any other allotment immediately abutting upon any public road, and the other situated partly at the back of such first-mentioned allotment, and each of them has a frontage of less than 50 ft. to a public road, it will be sufficient if each of the said allotments has a frontage of at least 8 ft. to a public road; provided such frontages adjoin for the full distance intervening between such public road and the first-mentioned allotment, and are thereafter kept adjoined; and provided that the area of each of the said adjoining allotments is not less than half an acre; and provided that not more than one house shall at any time be erected on each of the said allotments. In computing the said area the whole of any entrance, right-of-way, or approach giving access to any of the said back sections shall be disregarded.

7. Where any new house shall be erected upon any land in conformity with these by-laws, no person shall reduce, or cause to be reduced, the area provided for thereby so as or in such manner that such area shall be or become less than the minimum area hereby provided for; and such minimum area shall be exclusively maintained as the curtilage of and shall be exclusively appropriated to every such house.

8. Where any new house shall be erected in conformity with these by-laws upon any land, no person shall sell or dispose of any estate or interest in any portion less than the whole of any minimum area provided by these by-laws.

9. Where any new house shall be erected in conformity with these by-laws upon any land, no person shall purchase or acquire any estate or interest in any portion less than the whole of any minimum area provided for by these by-laws.

10. Clauses 6 and 7 of these by-laws shall not apply if no house shall be upon the land at the time of such sale, disposition, purchase, or acquisition.

11. If in the opinion of the Board the configuration of any land is such that the enforcement of a compliance with these by-laws or any clause thereof would operate to the inconvenience of any person, and it appears to the Board that the public health and the sanitary requirements of the district can be conserved by the relaxation of these by-laws, or any clause thereof, and the imposition of other terms and conditions, the Board may accordingly by resolution relax the same upon such terms and conditions as it may impose; and these by-laws shall, so long as but no longer than such terms and conditions are observed and complied with, have no application; and no person shall at any time make, cause, or suffer any default in the observance of or compliance with the said terms and conditions or any of them.

12. These by-laws shall apply to the whole district. They shall come into force upon their being gazetted.

13. If any person shall commit a breach of any of these by-laws he shall be liable to a fine not exceeding £5, and in case of a continuous breach to an additional fine not exceeding £5 for every day on which the breach is continued after the first day. The continued existence in a state contrary to any by-law of any work or thing shall be deemed a continuous breach within the meaning of this clause.

The above by-laws were made by special order of the Remuera Road Board, the resolution to make them having been passed at a special meeting of the Board held on the 28th day of August, 1911, and confirmed at a subsequent meeting thereof held on the 9th day of October, 1911.

The common seal of the Inhabitants of the Remuera Road Board District was affixed hereto at a meeting and by order of the Remuera Road Board held on the 9th day of October, 1911, in the presence of—

C. A. CAWKWELL,  
Chairman.  
PERCY SPENCER,  
Member.

I, Robert Haldane Makgill, the District Health Officer for the District of Auckland, approve of the foregoing by-law.

R. H. MAKGILL,  
District Health Officer.

I, Charles Sommers Wilson, Clerk of the Remuera Road Board, do hereby certify that the foregoing is a copy of a special order made by the Remuera Road Board, and that the same has been duly passed.

CHAS. S. WILSON,  
Clerk, Remuera Road Board.

*Resolution made by the Council of the Borough of Waimate.*

The Treasury,  
Wellington, 9th November, 1911.

THE following resolution, made by the Waimate Borough Council, is published in accordance with the provisions of the Local Bodies' Loans Act, 1908, and its amendment.

J. G. WARD,  
Minister of Finance.

BOROUGH OF WAIMATE.

*Certified Copy of Resolution.*

THAT, in pursuance and exercise of the powers vested in it in that behalf by the Local Bodies' Loans Act, 1908, and the Public Health Act, 1908, the Waimate Borough Council hereby resolves as follows: That, for the purpose of providing the interest and other charges on a loan of £3,000, authorized to be raised, under the above-mentioned Acts, for construction of drainage-works for portion of the Borough of Waimate, the said Waimate Borough Council hereby makes and levies a special rate of 3d. in the pound sterling upon the rateable value of all rateable property of the Borough of Waimate, comprising the whole of the Borough of Waimate; and that such special rate shall be an annually recurring rate during the currency of such loan, and be payable half-yearly on the 1st day of April and the 1st day of October in each year and every year during the currency of such loan, being a period of thirty-six years and a half, or until the loan is fully paid off.

I certify that the above is a true and correct copy of a resolution of the Waimate Borough Council passed on the 30th day of October, 1911, and that the same was passed subsequently to confirmation of special order authorizing loan to which above resolution relates.

C. DASH,  
Town Clerk.

*Resolution made by the Otautau River Board.*

The Treasury,  
Wellington, 10th November, 1911.

THE following resolution, made by the Otautau River Board, is published in accordance with the provisions of the Local Bodies' Loans Act, 1908.

J. G. WARD,  
Minister of Finance.

OTAUTAU RIVER BOARD.

At the monthly meeting of the Otautau River Board, duly convened, held on Monday, 6th November, 1911, the following resolution was passed:—

Moved by Mr. Salton, seconded by Mr. Ross, That, as the special order making special rate, adopted on 3rd April, 1911, and confirmed on 1st May, 1911, was not advertised in accordance with the provisions of section 60 of the River Boards Act, 1908, it is now resolved, in accordance with the provisions of section 4 of the Local Bodies' Loans Amendment Act, 1910, as follows: That, for the purpose of providing the interest and other charges on a loan of £500, authorized to be raised by the Otautau River Board, under the Local Bodies' Loans Act, 1908, for river-protective works on the Aparima River, in the vicinity of the Cabbage Tree Ford, also to pay the cost of the engineer's services in preparing plans and specifications, the costs incidental to raising the loan, and the first year's interest, the said Otautau River Board hereby makes and levies a special rate of 1/20 of a penny in the pound on the rateable value of all rateable value of the property in the Otautau River District as defined in the *New Zealand Gazette* of 29th September, 1886; and that such special rate shall be an annual-recurring rate during the currency of such loan, and be payable yearly on the 1st day of September in each and every year during the currency of such loan, being a period of thirty-six years and a half, or until the loan is fully paid off, as provided by the provisions of the New Zealand State-guaranteed Advances Act, 1909.

JOHN LINDSAY,  
Acting-Chairman, Otautau River Board.

*Resolution made by the Kaponga Town Board.*

The Treasury,  
Wellington, 14th November, 1911.

THE following resolution, made by the Kaponga Town Board, is published in accordance with the provisions of the Local Bodies' Loans Act, 1908, and its amendment.

J. G. WARD,  
Minister of Finance.

KAPONGA TOWN BOARD.

*Resolution of the Kaponga Town Board at a Special Meeting held Tuesday, 3rd October, 1911.*

Moved by the Chairman, Councillor A. H. Guy, seconded by Councillor Geo. Death, and carried unanimously:—

Resolved, That, in pursuance and exercise of the powers vested in it in that behalf by section 4 of the Local Bodies' Loans Amendment Act, 1910, the Kaponga Town Board hereby resolves as follows: That, for the purpose of providing the instalments in respect of principal and interest and also the other charges on a loan of £5,000, authorized to be raised by the Kaponga Town Board, under the Local Bodies' Loans Act, 1908, and its amendments, for the construction of water and drainage works within the Kaponga Town District, the said Kaponga Town Board hereby makes and levies a special rate of 1d. and 5/12 of a penny in the pound upon the rateable value of all rateable property of the Kaponga Town District; and that such special rate shall be an annual-recurring rate during the currency of such loan, and be payable yearly on the first day of January in each and every year during the currency of such loan, being a period of thirty-six years and a half, or until the loan is fully paid off.

A. H. GUY,  
Chairman.  
R. G. COOK,  
Clerk.

*Resolution made by the Council of the County of Hawera.*

The Treasury,  
Wellington, 14th November, 1911.

THE following resolution, made by the Hawera County Council, is published in accordance with the provisions of the Local Bodies' Loans Act, 1908, and its amendment.

J. G. WARD,  
Minister of Finance.

HAWERA COUNTY COUNCIL.

*Extract from the Minutes of Proceedings of the Hawera County Council at an Ordinary Meeting of such County Council held at the County Office, Hawera, on the 4th Day of November, 1911.*

RESOLUTION MAKING SPECIAL RATE.—PRINCES STREET  
EXTENSION LOAN, £350.

MOVED by Councillor Goodland, In pursuance and exercise of the powers vested in it in that behalf by the Local Bodies' Loans Act, 1908, and the Acts amending the same, the Hawera County Council hereby resolves as follows: That, for the purpose of providing the interest and other charges on a loan of £350, authorized to be raised by the Hawera County Council, under the above-mentioned Act, and the amendments thereof, for the purpose of the construction of Princes Street Extension in the Hawera Riding of the Hawera County—that is to say, from the main South Road to the Manawapou Road—the said Hawera County Council hereby makes and levies a special rate of 1d. and 1/16 of a penny in the pound upon the rateable value of all rateable property within the special-rating area, comprising Subdivisions 7, parts 8, 9, 10, 11, 19, 25, 26, 28, 30, 32, 34, 36, 38, 41, 44, 48, 49, 51, 53, 55, and 57, all of Section 190, Block 9, Hawera; and that such special rate shall be an annual-recurring rate during the currency of such loan and be payable yearly on the 5th day of July in each and every year during a period equal to the currency of such loan, being a period of thirty-six years and a half, or until the loan is fully paid off.—Seconded by Councillor Murdoch, and carried.

We hereby certify that the foregoing is a true copy of, and a correct extract from, the minutes of proceedings of the Hawera County Council at the meeting above mentioned.

WM. DUURS,  
Chairman.  
Geo. STRINGER,  
Acting County Clerk.

*Result of Poll for Proposed Loan.*

The Treasury,  
Wellington, 14th November, 1911.

THE following notice, received from the Mayor of the Borough of Kaiapoi, is published in accordance with the provisions of the Local Bodies' Loans Act, 1908.

J. G. WARD,  
Minister of Finance.

KAIAPOI BOROUGH COUNCIL.

PURSUANT to section 13 of the Local Bodies' Loans Act, 1908, I hereby give notice that at a poll of the ratepayers of the Borough of Kaiapoi taken on the 8th day of November, 1911, on the proposal of the Kaiapoi Borough Council to borrow the sum of £3,500 for—

Repairs and approaches to main traffic-bridge	£ 550
Fire-brigade buildings	2,000
Furniture and fittings	200
Drainage	15
Fencing, £15; belfry, £50	65
Repairs and new boiler, fire-engine	225
Interest for first year at 4½ per cent.	157
Sinking fund, 1 per cent.	35
Architect, and legal expenses	200
Contingencies	53
	£3,500

the number of votes recorded for the proposal was 226, and the number of votes recorded against the proposal was 63.

I therefore declare that the proposal was carried.

Dated this 9th day of November, 1911.

R. WYLIE,  
Mayor.

*Result of Poll for Proposed Loan.*

The Treasury,  
Wellington, 14th November, 1911.

THE following notice, received from the Mayor of the Borough of Gore, is published in accordance with the provisions of the Local Bodies' Loans Act, 1908.

J. G. WARD,  
Minister of Finance.

## BOROUGH OF GORE.

*Notice of Result of Poll on Proposal to raise a Loan.*

PURSUANT to section 13 of the Local Bodies' Loans Act, 1908, I hereby give notice that a poll of the ratepayers of the Borough of Gore was taken on the 7th day of November, 1911, on the proposal of the Gore Borough Council to borrow the sum of £6,000 for the following particular purposes, that is to say,—

Drainage extension in North, South, and East Wards	£ 3,000
Water extension in North, South, and East Wards	3,000
	£6,000

The number of votes recorded for the proposal was 214; the number of votes recorded against the proposal was 26.

I therefore declare that the proposal was carried.  
Dated at Gore, this 8th day of November, 1911.

D. L. POPPELWELL,  
Mayor.

*Result of Poll for Proposed Loan.*

The Treasury,  
Wellington, 14th November, 1911.

THE following notice, received from the Mayor of the Borough of Onslow, is published in accordance with the provisions of the Local Bodies' Loans Act, 1908, in substitution for that already gazetted on page 2436 of the *New Zealand Gazette*, 1911.

J. G. WARD,  
Minister of Finance.

## ONSLow BOROUGH COUNCIL.

*Notice of Result of Poll on Proposal to raise a Loan of £1,500 for and in respect of a Public Hall at Khandallah.*

PURSUANT to section 13 of the Local Bodies' Loans Act, 1908, I, the undersigned, Frank Holdsworth, Mayor of the Borough of Onslow, hereby give notice that a poll of the ratepayers of the Khandallah Ward of the Borough of Onslow was duly taken under the said statute on the 27th day of July, 1911, upon a proposal to raise a special loan of £1,500, under the said statute, for the purpose of the purchase of land for and the erection thereon and furnishing of a hall for the holding of public meetings and for purposes of enjoyment and recreation in and for the benefit of the Khandallah Ward of the Borough of Onslow, and for legal and other costs and incidental expenses of purchase and building and raising of loan, and also interest on loan for first year. Also that the number of votes recorded respectively for and against the said proposal was as follows: For the proposal, 68; against the proposal, 47; informal vote, 1.

And I therefore declare the said proposal to be carried.

F. HOLDSWORTH,  
Mayor of the Borough of Onslow.

*Results of Polls for Proposed Loans.*

The Treasury,  
Wellington, 15th November, 1911.

THE following notices, received from the Chairman of the Waitemata County Council, are published in accordance with the provisions of the Local Bodies' Loans Act, 1908.

J. G. WARD,  
Minister of Finance.

## COUNTY OF WAITEMATA.

*Notice of Result of Poll on Loan Proposal.*

PURSUANT to section 13 of the Local Bodies' Loans Act, 1908, I hereby give notice that a poll of the ratepayers of the Wainui Riding of the County of Waitemata was taken

on the 8th day of November, 1911, on the proposal of the Waitemata County Council to borrow the sum of £8,000 for the construction and improvement generally of the roads of the Wainui Riding of the County of Waitemata.

The number of votes recorded for the proposal was 55. The number of votes recorded against the proposal was 79. I therefore declare that the proposal was rejected.  
Dated this 9th day of November, 1911.

JAMES McLEOD,  
Chairman.

## COUNTY OF WAITEMATA.

*Notice of Result of Poll on Loan Proposal.*

PURSUANT to section 13 of the Local Bodies' Loans Act, 1908, I hereby give notice that a poll of the ratepayers of the Waikumete Riding of the County of Waitemata was taken on the 8th day of November, 1911, on the proposal of the Waitemata County Council to borrow the sum of £9,000 for the construction and improvement generally of the roads of the Waikumete Riding of the County of Waitemata.

The number of votes recorded for the proposal was 196. The number of votes recorded against the proposal was 37. I therefore declare that the proposal was carried.  
Dated this 9th day of November, 1911.

JAMES McLEOD,  
Chairman.

## COUNTY OF WAITEMATA.

*Notice of Result of Poll on Loan Proposal.*

PURSUANT to section 13 of the Local Bodies' Loans Act, 1908, I hereby give notice that a poll of the ratepayers of the Pukeatua Riding of the County of Waitemata was taken on the 8th day of November, 1911, on the proposal of the Waitemata County Council to borrow the sum of £4,000 for the construction and improvement generally of the roads of the Pukeatua Riding of the County of Waitemata.

The number of votes recorded for the proposal was 87. The number of votes recorded against the proposal was 32. I therefore declare that the proposal was carried.  
Dated this 9th day of November, 1911.

JAMES McLEOD,  
Chairman.

## COUNTY OF WAITEMATA.

*Notice of Result of Poll on Loan Proposal.*

PURSUANT to section 13 of the Local Bodies' Loans Act, 1908, I hereby give notice that a poll of the ratepayers of the Waitakerei Riding of the County of Waitemata was taken on the 8th day of November, 1911, on the proposal of the Waitemata County Council to borrow the sum of £10,000 for the construction and improvement generally of the roads of the Waitakerei Riding of the County of Waitemata.

The number of votes recorded for the proposal was 127. The number of votes recorded against the proposal was 17. I therefore declare that the proposal was carried.  
Dated this 9th day of November, 1911.

JAMES McLEOD,  
Chairman.

## COUNTY OF WAITEMATA.

*Notice of Result of Poll on Loan Proposal.*

PURSUANT to section 13 of the Local Bodies' Loans Act, 1908, I hereby give notice that a poll of the ratepayers of the Waipareira Riding of the County of Waitemata was taken on the 8th day of November, 1911, on the proposal of the Waitemata County Council to borrow the sum of £12,000 for the construction and improvement generally of the roads of the Waipareira Riding of the County of Waitemata.

The number of votes recorded for the proposal was 129. The number of votes recorded against the proposal was 45. I therefore declare that the proposal was carried.  
Dated this 9th day of November, 1911.

JAMES McLEOD,  
Chairman.

## COUNTY OF WAITEMATA.

*Notice of Result of Poll on Loan Proposal.*

PURSUANT to section 13 of the Local Bodies' Loans Act, 1908, I hereby give notice that a poll of the ratepayers of the Kumeu Riding of the County of Waitemata was taken

on the 8th day of November, 1911, on the proposal of the Waitemata County Council to borrow the sum of £10,000 for the construction and improvement generally of the roads of the Kumeu Riding of the County of Waitemata.

The number of votes recorded for the proposal was 52. The number of votes recorded against the proposal was 3.

I therefore declare that the proposal was carried.

Dated this 9th day of November, 1911.

JAMES McLEOD,  
Chairman.

COUNTY OF WAITEMATA.

*Notice of Result of Poll on Loan Proposal.*

PURSUANT to section 13 of the Local Bodies' Loans Act, 1908, I hereby give notice that a poll of the ratepayers of the Mairatahi Riding of the County of Waitemata was taken on the 8th day of November, 1911, on the proposal of the Waitemata County Council to borrow the sum of £7,000 for the construction and improvement generally of the roads of the Mairatahi Riding of the County of Waitemata.

The number of votes recorded for the proposal was 83. The number of votes recorded against the proposal was 5.

I therefore declare that the proposal was carried.

Dated this 9th day of November, 1911.

JAMES McLEOD,  
Chairman.

COUNTY OF WAITEMATA.

*Notice of Result of Poll on Loan Proposal.*

PURSUANT to section 13 of the Local Bodies' Loans Act, 1908, I hereby give notice that a poll of the ratepayers of the Titirangi Riding of the County of Waitemata was taken on the 8th day of November, 1911, on the proposal of the Waitemata County Council to borrow the sum of £3,000 for the construction and improvement generally of the roads of the Titirangi Riding of the County of Waitemata.

The number of votes recorded for the proposal was 32. The number of votes recorded against the proposal was 1.

I therefore declare that the proposal was carried.

Dated this 9th day of November, 1911.

JAMES McLEOD,  
Chairman.

COUNTY OF WAITEMATA.

*Notice of Result of Poll on Loan Proposal.*

PURSUANT to section 13 of the Local Bodies' Loans Act, 1908, I hereby give notice that a poll of the ratepayers of the Birkenhead Riding of the County of Waitemata was taken on the 8th day of November, 1911, on the proposal of the Waitemata County Council to borrow the sum of £3,000 for the construction and improvement generally of the roads of the Birkenhead Riding of the County of Waitemata.

The number of votes recorded for the proposal was 111. The number of votes recorded against the proposal was 50.

I therefore declare that the proposal was carried.

Dated this 9th day of November, 1911.

JAMES McLEOD,  
Chairman.

*Result of Poll for Proposed Loan.*

The Treasury,  
Wellington, 15th November, 1911.

THE following notice, received from the Chairman of the Waimarino County Council, is published in accordance with the provisions of the Local Bodies' Loans Act, 1908.

J. G. WARD,  
Minister of Finance.

WAIMARINO COUNTY COUNCIL.

*Notice of Result of Poll on Proposal to raise a Loan.*

PURSUANT to section 13 of the Local Bodies' Loans Act, 1908, I hereby give notice that a poll of the ratepayers of the Raetihi Riding of the County of Waimarino was taken on the 9th day of November, 1911, on the proposal of the

Waimarino County Council to borrow the sum of £1,250 for the purposes of—

- |   |       |
|---|-------|
| (1.) Stumping of Queen Street, King Street, Pitt Street, and Seddon Street ...  | £ 125 |
| (2.) Forming and metalling King Street from Duncan Street to Valley Road, and forming and gritting footpath on north side from Ward Street to Makotuku Valley Road ...  | 280   |
| (3.) Forming and metalling of Queen Street from Duncan Street to Parapara Road, and forming and gritting footpaths from Duncan Street to Ward Street on both sides, and from Ward Street to Parapara Road on south side ...   | 275   |
| (4.) Forming and metalling of Pitt Street from Duncan Street to Parapara Road, and metalling from Duncan Street to Balance Street, and forming and gritting footpaths from Ward Street to Parapara Road on the north side, and from Ward Street to Balance Street on both sides ... | 395   |
| (5.) Forming and metalling Plunket Street from Seddon Street to Bolton's section ...  | 130   |
| (6.) Formation of Ranfurly Terrace from Ward Street to Duncan Street ...  | 45    |

The number of votes recorded for the proposal was 22. The number of votes recorded against the proposal was nil.

I therefore declare that the proposal was carried.

Dated at Raetihi, this 9th day of November, 1911.

PETER BRASS,  
Chairman of the Waimarino County Council.

*Authorizing the Laying-off of Alexandra Street, Mary Street, Coronation Street, George Street, Edward Street, and Victoria Street, in the Town of Huntly Extension No. 9, of a Width of not less than 66 ft.*

Department of Lands,  
Wellington, 8th November, 1911.

IN pursuance of the power and authority conferred upon me by section 15 of the Land Act, 1908, I hereby authorize the laying-off of Alexandra Street, Mary Street, Coronation Street, George Street, Edward Street, and Victoria Street, in the Town of Huntly Extension No. 9, Auckland Land District, of a width of not less than 66 ft. instead of 99 ft.

J. CARROLL,  
For Minister of Lands.

*Authorizing the Laying-off of James Street, in the Town of Waipukurau Extension No. 16, of a Width of not less than 66 ft.*

Department of Lands,  
Wellington, 8th November, 1911.

IN pursuance of the power and authority conferred upon me by section 15 of the Land Act, 1908, I hereby authorize the laying-off of James Street, in the Town of Waipukurau Extension No. 16, Hawke's Bay Land District, of a width of not less than 66 ft. instead of 99 ft.

J. CARROLL,  
For Minister of Lands.

*Authorizing the Laying-off of Cornfort Street Extension, Mata Street Extension, Karaka Street Extension, and Karewa Street, in the Town of Castlecliff Extension No. 4, of a Width of not less than 66 ft.*

Department of Lands,  
Wellington, 8th November, 1911.

IN pursuance of the power and authority conferred upon me by section 15 of the Land Act, 1908, I hereby authorize the laying-off of Cornfort Street Extension, Mata Street Extension, Karaka Street Extension, and Karewa Street, in the Town of Castlecliff Extension No. 4, Wellington Land District, of a width of not less than 66 ft. instead of 99 ft.

J. CARROLL,  
For Minister of Lands.

*Amending Boundaries of Taumarunui Maori Village or Kainga.*

Native Department,  
Wellington, 11th November, 1911.

IT is hereby notified that His Excellency the Governor has approved, in terms of section 6 of the Maori Councils Amendment Act, 1903, of the boundaries of the village or kainga of Taumarunui as approved and published in the *New Zealand Gazette* of 20th October, 1904, page 2450, being amended by the addition of the following words: "All sections within these boundaries leased to Europeans are excluded."

J. CARROLL,  
Native Minister.

*Alterations to the Scale of Fares, Rates, and Charges in Force upon the New Zealand Government Railways.*

IN pursuance of all powers and authorities enabling me under the Government Railways Act, 1908, I, John Andrew Millar, Minister of Railways, do hereby make the following alterations in the scale of fares, rates, and charges in force on the New Zealand Government railways open for traffic, such alterations to come into force on and after the 27th day of November, 1911.

PART I.—PASSENGERS.

LOCAL FARES AND REGULATIONS, WELLINGTON DISTRICT.

Cancel—

The suburban fares appearing in the *New Zealand Gazette* of 5th November, 1908, will apply also as under:—

From or to—	To or from—
Wellington (Thorndon)	... Ngaio, Khandallah, and Johnsonville.

Insert—

The suburban fares appearing in the *New Zealand Gazette* of 5th November, 1908, will apply also as under:—

From or to—	To or from—
Wellington (Thorndon)	... Ngaio - Plimmerton and all intermediate stations.

As witness my hand, this fourteenth day of November, one thousand nine hundred and eleven.

J. A. MILLAR,  
Minister of Railways.

*Notice to Mariners No. 140 of 1911.*

Marine Department,  
Wellington, N.Z., 3rd November, 1911.

THE following Notices to Mariners, received from the Hydrographic Office, Washington, D.C., United States, America, are published for general information.

J. A. MILLAR.

OREGON.

COOS BAY.—LIGHTS TO BE ESTABLISHED.—About 1st October, 1911, the following lights will be established in Coos Bay, Oregon:—

*Jarvis Range Lights.*—On 14th August, 1911, Pony Bend light, Coos Bay, Oregon, was moved 5 yards north-eastward from its former position, without change in characteristic. This light will be the front light of the range.

The rear light will be a *fixed white* post-lantern light established 30 ft. above the water on a white cross-arm attached to a white post with black target about 600 yards 260° from the front light.

*Porter Light.*—A *fixed white* post-lantern light exhibited 15 ft. above the water from a red cross-arm attached to an unpainted pile dolphin erected in 10 ft. of water on the eastern side of the channel opposite Porter Mill Wharf.

Approx. position: Lat. 43° 23' N., long. 124° 13' W.  
Bearings will be published later.

WASHINGTON.

PUGET SOUND.—RICH PASSAGE.—ORCHARD ROCKS.—GAS-BUOY TO BE ESTABLISHED.—LIGHT AND BUOY TO BE DISCONTINUED.—About 1st October, 1911, Orchard Rocks gas-buoy No. 4, conical in shape, surmounted by a pyramidal lattice-work and lantern, and showing a *flashing white* light every 3 seconds—thus, flash 0.3 second, eclipsed 2.7 seconds—

will be established in the position now occupied by Orchard Rocks buoy 4, Rich Passage, Puget Sound, Washington.

On the same date Orchard Rocks buoy 4 and Orchard Point light will be permanently discontinued.

BRITISH COLUMBIA.

VANCOUVER ISLAND.—VICTORIA HARBOUR ENTRANCE.—BROTCHY LEDGE LIGHT REPORTED IRREGULAR.—Captain Rushforth, of the steamer "Candidate," reports that on 25th July, and again on 23rd August, 1911, when off the port of Victoria, British Columbia, he observed that the light on Brotsky Ledge was showing *intermittent white* every 10 seconds instead of every minute, as stated in the Light Lists and Sailing Directions. Captain Rushforth was informed by a local seaman that Brotsky Ledge light was very irregular, and sometimes showed *fixed white*.

Approx. position: Lat. 48° 24' 20" N., long. 123° 23' 40" W.

RED SEA.

PERIM ISLAND.—CHANGE IN CHARACTERISTIC OF LIGHT.—FURTHER INFORMATION.—Referring to Notice to Mariners No. 31 (2187) of 1911, further notice is given that the revolving light on the eastern end of Perim Island, Red Sea, is to be replaced by a *flashing* light, showing 1 group of 4 flashes.

During the work of transformation a *flashing white* light every minute is exhibited.

Approx. position: Lat. 12° 39' 14" N., long. 43° 25' 59" E.

BAY OF BENGAL.

GULF OF MARTABAN.—DOUBLE ISLAND LIGHT.—OBSCURED SECTOR DISCONTINUED.—Referring to Notice to Mariners No. 21 (1422) of 1911, further notice is given that the obscured sector in Double Island light, Gulf of Martaban, between the bearings of 155° and 164°, has been discontinued, the light now showing from 173° to 353°.

Approx. position: Lat. 15° 52' N., long. 97° 35' E.

CALIFORNIA.

SAN FRANCISCO BAY.—POINT BLUNT.—BUOY TO BE REPLACED BY BELL-BUOY.—About 15th October, 1911, Point Blunt bell-buoy, painted black and numbered 1, will be established off Point Blunt, San Francisco Bay, California, in place of Point Blunt buoy, a red and black horizontally striped can, which will be discontinued.

Approx. position: Lat. 37° 51' 5" N., long. 122° 25' W.

ARGENTINA.

BAHIA BLANCA (PORT BELGRANO) APPROACH.—SHOAL REPORTED.—Information has been received that on 31st May, 1911, the steamer "Santa Rita," drawing 25 ft., struck several times on a shoal southward of Asuncion Point, Argentina, in (approximately) latitude 39° 5' S., longitude 60° 41' W.

BRAZIL.

EAST COAST.—RIO DE JANEIRO BAY.—TABACI ISLET.—LIGHT ESTABLISHED.—LIGHT-BUOY WITHDRAWN.—The Brazilian Government has given notice that a *flashing red* light every 4 seconds has been established on the rocks west-north-westward of Tabaci Islet, Rio de Janeiro Bay, Brazil. The light is exhibited 32 ft. above high water from a red iron truss, and should be visible 10 miles.

Approx. position: Lat. 22° 46' S., long. 43° 6' 45" W.

The light-buoy marking Trinta Reis Rocks on the south-western side of Tabaci Islet has been discontinued.

SUMATRA.

EAST COAST.—DURIAN STRAIT.—MIDDLEBURG REEF.—LIGHT ESTABLISHED.—Referring to Notice to Mariners No. 35 (2543) of 1911, further notice is given that an *intermittent red* light has been established on the eastern side of Middleburg Reef, Durian Strait, east coast of Sumatra.

Further information will be given.

Approx. position: Lat. 0° 51' 18" N., long. 103° 34' 18" E.

HAWAIIAN ISLANDS.

MAUI ISLAND.—MAALAEA BAY.—KIHEI REEF.—DECREASED DEPTHS.—On 22nd August, 1911, careful soundings were taken on the 3-fathom spot on Kihei Reef, Maalaea Bay, south coast of Maui Island, and two spots having depths of 14 ft. 8 in. and 15 ft. respectively were found in the south-western quadrant of the circle indicating the shoal on the chart.

The whole shoal is about 200 ft. in diameter. Within 150 ft. of the Kihei Reef buoy the water deepens from 3½ fathoms to 7 fathoms.

A 2- to 3-knot current sets to the north-westward in the vicinity of Kihei Reef. Strangers should not attempt to pass between the buoy and the shore.

Approx. position: Lat. 20° 45' 46" N., long. 156° 28' 14" W.

*Notice to Mariners No. 142 of 1911.*

**NAPIER HARBOUR.—DREDGING OFF INNER HARBOUR.**

Marine Department,  
Wellington, N.Z., 11th November, 1911.

**T**HE Napier Harbour Board have notified that the dredge "Whakarire" will be employed dredging on a patch situated half-way between the inner harbour pier heads and the roadstead mooring-buoy.

The dredge will show *two black balls* or shapes in a vertical line one over the other during *daytime*, and *two red lights* in a vertical line one over the other, as well as the usual anchor lights, at night-time.

Vessels are warned to give the dredge a clearance of at least a cable.

Charts, &c., affected: Admiralty Chart No. 2513; "New Zealand Pilot," eighth edition, 1908, Chapter iv, page 134.

J. A. MILLAR.

*Notice to Mariners No. 144 of 1911.*

**AUCKLAND HARBOUR.—ERECTION OF DOLPHINS IN FREEMAN'S BAY.**

Marine Department,  
Wellington, N.Z., 15th November, 1911.

**T**HE Auckland Harbour Board have notified that three temporary timber dolphins are being erected as guides for the Board's dredges parallel with the north wall at Freeman's Bay. The most western one is 600 ft. eastward of the west end, and 400 ft. north of the wall, and the other two are in same line, 150 ft. between centres. The overall distance from the western to the eastern dolphin is 330 ft.

The following true bearings mark the position of eastern and western dolphins:—

*Eastern Dolphin.*

Stokes Point Trig. ....	N. 32° 7' W.
Mount Victoria Flagstaff ....	N. 69° 16' E.

*Western Dolphin.*

Stokes Point Trig. ....	N. 31° 6' W.
Mount Victoria Flagstaff ....	N. 69° 48' E.

Each dolphin is lighted at night with a *white fixed* light.

Charts, &c., affected: Admiralty Chart No. 1970; "New Zealand Pilot," eighth edition, 1908, Chapter ii, page 42.

J. A. MILLAR.

*Notice to Mariners No. 145 of 1911.*

**AUCKLAND HARBOUR.—BUOY TO BE PLACED IN MOTUIHI CHANNEL.**

Marine Department,  
Wellington, N.Z., 15th November, 1911.

**T**HE Auckland Harbour Board have notified that on or about 18th December the following buoys will be placed in the Motuihi Channel:—

(1.) A large red buoy to be moored over the mid. channel rock, with  $3\frac{1}{2}$  fathoms at L.W.S., mentioned in Notices Nos. 118 and 130 of 1911. West extreme of Brown's Island S. 31° W., south extreme Motu Tapu N. 65½° W.

(2.) A black buoy to be moored off the N.W. end of Motuihi, about 200 ft. outside the 5-fathom line, in 8½ fathoms of water L.W.S., the south point of Motu Tapu being S. 77° W., and west extreme Brown's Island S. 30° W.

(3.) A second black buoy to be moored in 7 fathoms approximately 500 ft. south from the black buoy now moored in the channel, which is to be removed. South point Motu Tapu bearing N. 81° W., west extreme Brown's Island S. 33° W. All bearings magnetic; variation used, 15° E. Correct position of buoys will be given when placed.

Charts, &c., affected: Admiralty Chart No. 1896; "New Zealand Pilot," eighth edition, 1908, Chapter ii, page 40; "New Zealand Nautical Almanac," 1912, page 323.

J. A. MILLAR.

*Despatch: Convention to amend Extradition Treaty with Belgium.*

Department of Justice,  
Wellington, 13th November, 1911.

**T**HE following despatch and enclosure, received from His Majesty's Principal Secretary of State for the Colonies, are published for general information.

JOHN G. FINDLAY,  
Minister of Justice.

(New Zealand.—No. 333.)

Downing Street, 22nd September, 1911.

MY LORD,—With reference to my despatch No. 310, of the 5th of September, I have the honour to transmit to you, for the information of your Ministers, copies of an Order of His Majesty in Council giving effect to the Convention which was concluded on the 3rd of March, 1911, between the United Kingdom and Belgium, amending Article 6 of the Extradition Treaty with Belgium of 29th October, 1901.

I have, &c.,

L. HARCOURT.

Governor the Right Honourable Lord Islington,  
K.C.M.G., D.S.O., &c.

**BELGIUM, EXTRADITION ORDER IN COUNCIL, 1911.**

At the Court at Buckingham Palace, the 8th day of August, 1911.

Present:

THE KING'S MOST EXCELLENT MAJESTY.

Lord President.

Lord Pentland.

Lord Chamberlain.

Mr. Charles Hobhouse.

WHEREAS by the Extradition Acts, 1870 to 1906, it was amongst other things enacted that, where an arrangement has been made with any foreign State with respect to the surrender to such State of any fugitive criminals, His Majesty may, by Order in Council, direct that the said Acts shall apply in the case of such foreign State; and that His Majesty may, by the same or any subsequent Order, limit the operation of the Order, and restrict the same to fugitive criminals who are in or suspected of being in the part of His Majesty's dominions specified in the Order, and render the operation thereof subject to such conditions, exceptions, and qualifications as may be deemed expedient:

And whereas a Treaty was concluded on the 29th day of October, 1901, between His late Majesty King Edward VII and His late Majesty the King of the Belgians, for the Extradition of Criminals, which Treaty was amended by a supplementary Convention concluded on the 5th day of March, 1907:

And whereas a further Convention was concluded on the 3rd day of March, 1911, between His Majesty and His Majesty the King of the Belgians, amending Article 6 of the aforesaid Treaty, which Convention is in the terms following:—

His Majesty the King of the United Kingdom of Great Britain and Ireland and of the British Dominions beyond the Seas, Emperor of India, and His Majesty the King of the Belgians, being desirous of amending the provisions of Article 6 of the Treaty between Belgium and Great Britain of the 29th October, 1901, for the mutual extradition of fugitive criminals, have named as their respective Plenipotentiaries, for this purpose, that is to say:

His Majesty the King of the United Kingdom of Great Britain and Ireland, the Right Honourable Sir Edward Grey, a Baronet of the United Kingdom, a Member of Parliament, His Majesty's Principal Secretary of State for Foreign Affairs;

And His Majesty the King of the Belgians, Count de Lalaing, His Majesty's Envoy Extraordinary and Minister Plenipotentiary at the Court of His Britannic Majesty;

Who, having reciprocally communicated their full powers, found to be in good and due form, have agreed as follows:—

ARTICLE 1.

The following article is substituted for Article 6 of the Extradition Treaty of the 29th October, 1901:—

When a person shall have been extradited by one of the High Contracting Parties, that person, until he has returned to the country from which he had been extradited, or until he has had opportunity of returning to it, shall not be detained or brought to justice in the State to which

he has been handed over for any crime or on any other charge whatever prior to the extradition, except those in respect of which the extradition has been accorded.

Neither shall that person, until he has had an opportunity of returning to the country from which he has been extradited, be handed over to a third State.

ARTICLE 2.

The present Convention shall be ratified, and the ratifications shall be exchanged at London, as soon as possible.

It shall come into force ten days after its publication in the manner prescribed by law in the respective countries, and shall have the same force and duration as the Treaty to which it relates.

In witness whereof the respective Plenipotentiaries have signed the present Convention, and have affixed thereto their seals.

Done in duplicate, at London, the 3rd March, 1911.

[L.S.] E. GREY.  
[L.S.] J. LAING.

And whereas the ratifications of the above Convention were exchanged at London on the 10th day of May, 1911 :

Now, therefore, His Majesty, by and with the advice of His Privy Council, and in virtue of the authority committed to Him by the said recited Acts, doth order, and it is hereby ordered, that from and after the 25th day of August, 1911, the said Acts shall apply in the case of Belgium under and in accordance with the said Treaty of the 29th October, 1901, and the supplementary Conventions of the 5th March, 1907, and 3rd March, 1911 :

Provided always that the operation of the said Acts shall be and remain suspended within the Dominion of Canada so long as an Act of the Parliament of Canada, being Part I of chapter 155 of "The Revised Statutes of Canada, 1906," and entitled "An Act respecting the Extradition of Fugitive Criminals," shall continue in force there, and no longer.

ALMERIC FITZROY.

[Extract from the London Gazette of Tuesday, 15th August, 1911.]

Revocation of Appointment of Bonding Warehouse.

CUSTOMS.—In exercise of the authority in me for this purpose vested, I, the Minister of Customs, do, by this order under my hand, revoke and annul the appointment of the undermentioned warehouse for the reception and security of goods entered to be warehoused without payment of duty upon the first entry thereof, namely :—

Port of Poverty Bay.

The warehouse known as

THE GISBORNE BOND,

as appointed and described in Minister's Order No. 830, of the 7th day of January, 1907.

Given under my hand, at Wellington, this ninth day of November, one thousand nine hundred and eleven.

R. MCKENZIE,  
Minister of Customs.

Minister's Order No. 981.]

Approving and appointing a Bonding Warehouse.

CUSTOMS.—In exercise of the powers in me for this purpose vested by the Customs Law Act, 1908, I, the Minister of Customs, do hereby approve and appoint the undermentioned warehouse to be a warehouse for the reception of goods under bond, namely :—

Port of Poverty Bay.

Portion of a brick building situated on Section 74, Gladstone Road, Borough of Gisborne, to be known as

THE GISBORNE BOND.

Given under my hand, at Wellington, this ninth day of November, one thousand nine hundred and eleven.

R. MCKENZIE,  
Minister of Customs.

Minister's Order No. 982.]

Notice of Intention to take Land in Blocks VIII and X, Awakino North, and I, II, and III, Awakino Survey Districts.

NOTICE is hereby given that it is proposed, under the provisions of the Public Works Act, 1908, the Scenery Preservation Act, 1908, and the Scenery Preservation Amendment Act, 1910, to take the land described in the Schedule hereto for scenery-preservation purposes. And notice is hereby further given that the plan of the land so required to be taken is deposited in the post-office at Awakino, and is there open for inspection; and that all persons affected by the taking of the said land should, if they have any well-grounded objections to the taking of such land, set forth the same in writing, and send such writing, within forty days from the first publication of this notice, to the Minister of Public Works, at Wellington.

SCHEDULE.

THE parcels of land required to be taken :—

Approximate Area of each of the Parcels of Land required to be taken.		Being	Situated in Blocks	Situated in Survey District of	Shown on Plan	Coloured on Plan
A.	R. P.	Mangoira No. 2 .. ..	VIII and X	Awakino North	P.W.D. 30349	Edged red.
2,690	0 0	" No. 1 .. ..	II and III	Awakino ..		
260	0 0	" Native land .. ..	II	Awakino ..		
94	2 16	" Section 12, Native reserve .. ..	"	" ..		
76	0 0	(16244, blue)	I	" ..	"	"

All in the Land District of Auckland; as the same are more particularly delineated on the plan marked and coloured as above mentioned, and deposited in the office of the Minister of Public Works, at Wellington, in the Wellington Provincial District.

As witness my hand, at Wellington, this eleventh day of November, one thousand nine hundred and eleven.

R. MCKENZIE,  
Minister of Public Works.

*Permits to import Opium.*

Department of Trade and Customs,  
Wellington, 13th November, 1911.

IT is hereby notified for public information that permits to import opium in forms which though not suitable for smoking may be made suitable have been granted to the following persons and firms, subject to the provisions of the Opium Act, 1908, the Opium Amendment Act, 1910, and the regulations made thereunder:—

Name.	District.
Auckland Drug Company .. .. .	Auckland.
De Castro, G. P. . . . .	Paeroa.
Fairbairn, Wright, and Co. . . . .	Auckland.
George, J. R. . . . .	"
Henderson, J. G. . . . .	"
Irwin, T. W. . . . .	"
Kempthorne, Prosser, and Co.'s New Zealand Drug Company (Limited)	"
Reed, F. W. . . . .	Whangarei.
Sharland and Co. (Limited) . . . . .	Auckland.
Mann, A. W. J. . . . .	Gisborne.
Townson, W. . . . .	"
Bates, J. W. . . . .	Hastings.
Fairbairn, Wright, and Co. . . . .	Wellington.
Kempthorne, Prosser, and Co.'s New Zealand Drug Company (Limited)	"
Sharland and Co. (Limited) . . . . .	"
Young's Chemical Company . . . . .	"
Tingey, J. S. . . . .	Feilding.
Bonnington, G. (Limited) . . . . .	Christchurch.
Cook and Ross . . . . .	"
Kempthorne, Prosser, and Co.'s New Zealand Drug Company (Limited)	"
Stevens, H. F. . . . .	"
United Friendly Societies' Dispensary	Lytelton.
White-Parsons, A. V. . . . .	"
Hayman, P., and Co. . . . .	Dunedin.
Kempthorne, Prosser, and Co.'s New Zealand Drug Company (Limited)	"
Stevens, H. F. . . . .	"
United Friendly Societies' Dispensary	Invercargill.
Williams, W. E. . . . .	Hokitika.

R. McKENZIE,  
Minister of Customs.

*Subsidies to Public Libraries.*

Education Department,  
Wellington, 8th November, 1911.

NOTICE is hereby given that the sum of £4,000 has been voted by Parliament for distribution to public libraries.

The distribution will take place on the 3rd February, 1912, and no claim will be entitled to consideration that shall not have been sent in in due form and received by the Secretary for Education, Wellington, on or before the 27th January, 1912.

1. A library to be entitled to a subsidy must be public in the sense of belonging to the public, and of not being under the control of an association, society, or club whose membership is composed of a section of the community only, and if within a borough it must be open to the public free of charge. The receipts for the year from subscriptions and donations must not have been less than £2, exclusive of moneys received from endowments, or from Government, or from Borough or County Councils, or for special building purposes, or as rent, hire, or consideration for the use of any room, or building, or land belonging to the institution, in respect of none of which will subsidy be allowed. The net proceeds of concerts, lectures, or other entertainments on behalf of the current expenses of the library will be regarded as voluntary contributions. A subsidy will not be given to more than one library in the same town.

2. In the division of the vote a nominal addition of £25 will be made to the amount of the income of each library derived from subscriptions, donations, and rates, and the vote will be divided according to the amounts thus augmented; but no library will receive credit for a larger income than £75—that is, in no case will the augmented amount on which distribution is based exceed £100.

3. The whole of the subsidy must be expended without delay in the purchase of books for the library.

4. Application to share in the distribution must be by means of a statutory declaration by the Chairman, or Secre-

tary, or Treasurer of the institution on behalf of which it is made, and must be accompanied by a statement of the receipts and expenditure of the institution for the year ending on the 31st day of December, 1911; and such declaration must be on the form provided for the purpose, which form shall be as follows:—

## DECLARATION.

I, [Name], of [Place of abode], [Occupation], do solemnly and sincerely declare that I am Chairman [or Secretary, or Treasurer] of the [Name of institution]; that during the year ending on the 31st day of December, 1911, the receipts of the aforesaid institution for the maintenance of the library only were as follows: From rates levied by a local governing body under Part I of the Libraries and Mechanics' Institutes Act, 1908, or the Municipal Corporations Act, 1908, pounds shillings and pence; from the subscriptions of members, pounds shillings and pence; and from voluntary contributions other than members' subscriptions, pounds shillings and pence; that the library is public in the sense of belonging to the public, and is not under the control of an association, society, or club whose membership is composed of a section of the community only; that the information hereinafter furnished by me in the appendix hereto is correct in every particular; that the abstract of accounts is a true statement of the receipts and expenditure of the institution for the year herein specified; that the whole of the subsidy received during the year was expended in the purchase of books for the library; and that by the rules of the library it is open to the public free of charge.

And I make this solemn declaration conscientiously believing the same to be true, and by virtue of the Justices of the Peace Act, 1908. (Signature.)

Declared at , this day of , 191 ,  
before me— , Justice of the Peace [or Solicitor, or Notary Public].

[Here affix and cancel a stamp at 2s. 6d.]

[NOTE.—The words relating to last year's subsidy and to free admission may be struck out if they are not applicable. The words in brackets are not part of the form, but indicate matter to be inserted or substituted.]

Copies of the form of application may be obtained from the Secretary for Education, Wellington, and from the Secretary of any Education Board.

THOS. MACKENZIE,  
Acting Minister of Education.

*Tenders for Rural Delivery from Waihao Forks through Allanholm Settlement.*

General Post Office,  
Wellington, 14th November, 1911.

TENDERS will be received at the Chief Post-office, Timaru, until 5 p.m. on Monday, the 27th November, 1911, for a three-weekly mail-service from Waihao Forks Post-office delivering and collecting correspondence through Allanholm Settlement.

The lowest or any tender will not necessarily be accepted. Forms of tender can be obtained at Waimate and Timaru Post-offices.

D. ROBERTSON,  
Secretary.

*Notice by the Public Trustee under the Public Trust Office Act, 1908 (Part II).*

To the owner or owners of a parcel of land containing by admeasurement 35 perches, more or less, being Section 10, Block XXI, Town of Gore, in the Provincial District of Otago. The last registered owners of the said land are William Stewart and William Robertson, both of Invercargill, contractors, who cannot now be traced.

WHEREAS the Public Trustee has instituted inquiries, and has not thereby ascertained who the owner or owners of the above-described land is or are, and believes that such owner is, or owners are, not in the Dominion:

Now, this notice calls upon such owner or owners, within six months of the date of the publication of this notice in this Gazette, to establish to the satisfaction of the Public Trustee his or their title to the land specified in this notice; and, if such owner does or owners do not, within the time limited, so establish his or their title, the Public Trustee will exercise the powers and authorities granted to him in and by the Public Trust Office Act, 1908 (Part II).

Dated this 15th day of November, 1911.

FRED. FITCHETT,  
Public Trustee.



Traffic Returns.

NEW ZEALAND RAILWAYS.—Traffic Returns for the period ending 14th October, 1911, and for the corresponding period, 1910:—

WHANGAREI-KAWAKAWA SECTION.

Table with 6 columns: Passengers, S., R., Total, S., R., Total. Rows include 1st Class, 2nd Class, Total, Season Tickets, PARCELS, ETC.,--.

Table with 2 columns: Goods, No., No. Rows include Drays, Cattle, Calves, Sheep, Pigs, Total.

Table with 2 columns: Chaff, Lime, &c., Tons., Tons. Rows include Wool, Firewood, Timber, Grain, Merchandise, Minerals, Total.

Table with 4 columns: Revenue, £ s. d., £ s. d. Rows include Passengers, Parcels, Luggage, & Mails, Goods, Miscellaneous, Rents and Commission, Total.

KAIHU SECTION.

Table with 6 columns: Passengers, S., R., Total, S., R., Total. Rows include 1st Class, 2nd Class, Total, Season Tickets.

Table with 2 columns: PARCELS, ETC.,-- No., No. Rows include Parcels, Horses, Carriages, Dogs, Total.

Table with 2 columns: Goods, No., No. Rows include Drays, Cattle, Calves, Sheep, Pigs, Total.

Table with 2 columns: Chaff, Lime, &c., Tons., Tons. Rows include Wool, Firewood, Timber, Grain, Merchandise, Minerals, Total.

Table with 4 columns: Revenue, £ s. d., £ s. d. Rows include Passengers, Parcels, Luggage, & Mails, Goods, Miscellaneous, Rents and Commission, Total.

GISBORNE SECTION.

Table with 6 columns: Passengers, S., R., Total, S., R., Total. Rows include 1st Class, 2nd Class, Total, Season Tickets.

GISBORNE SECTION—continued.

Table with 3 columns: PARCELS, ETC.,-- 1911, 1910. Rows include Parcels, Horses, Carriages, Dogs, Total.

Table with 2 columns: Goods, No., No. Rows include Drays, Cattle, Calves, Sheep, Pigs, Total.

Table with 2 columns: Chaff, Lime, &c., Tons., Tons. Rows include Wool, Firewood, Timber, Grain, Merchandise, Minerals, Total.

Table with 4 columns: Revenue, £ s. d., £ s. d. Rows include Passengers, Parcels, Luggage, & Mails, Goods, Miscellaneous, Rents and Commission, Total.

NORTH ISLAND MAIN LINES AND BRANCHES.

Table with 6 columns: Passengers, S., R., Total, S., R., Total. Rows include 1st Class, 2nd Class, Total, Season Tickets.

Table with 2 columns: PARCELS, ETC.,-- No., No. Rows include Parcels, Horses, Carriages, Dogs, Total.

Table with 2 columns: Goods, No., No. Rows include Drays, Cattle, Calves, Sheep, Pigs, Total.

Table with 2 columns: Chaff, Lime, &c., Tons., Tons. Rows include Wool, Firewood, Timber, Grain, Merchandise, Minerals, Total.

Table with 4 columns: Revenue, £ s. d., £ s. d. Rows include Passengers, Parcels, Luggage, & Mails, Goods, Miscellaneous, Rents and Commission, Total.

SOUTH ISLAND MAIN LINES AND BRANCHES.

Table with 6 columns: Passengers, S., R., Total, S., R., Total. Rows include 1st Class, 2nd Class, Total, Season Tickets.

Table with 2 columns: PARCELS, ETC.,-- No., No. Rows include Parcels, Horses, Carriages, Dogs, Total.

SOUTH ISLAND MAIN LINES AND BRANCHES—*ctd.*

	1911.	1910.
Goods,—	No.	No.
Drays .. ..	100	92
Cattle .. ..	4,186	4,834
Calves .. ..	571	493
Sheep .. ..	71,007	53,452
Pigs .. ..	2,388	3,707
<b>Total .. ..</b>	<b>78,252</b>	<b>62,578</b>

	Tons.	Tons.
Chaff, Lime, &c. ..	8,604	8,016
Wool .. ..	1,061	1,109
Firewood .. ..	2,624	2,850
Timber .. ..	18,398	16,510
Grain .. ..	44,195	50,810
Merchandise .. ..	28,911	33,369
Minerals .. ..	59,021	53,581
<b>Total .. ..</b>	<b>162,814</b>	<b>166,195</b>

REVENUE,—	£ s. d.	£ s. d.
Passengers .. ..	29,422 2 5	30,361 6 0
Parcels, Luggage, & Mails	6,426 16 10	6,313 2 4
Goods .. ..	55,505 4 5	53,727 10 6
Miscellaneous .. ..	2,205 1 11	1,665 12 9
Rents and Commission	3,437 18 9	3,088 7 0
<b>Total .. ..</b>	<b>£96,997 4 4</b>	<b>£95,155 18 7</b>

WESTLAND SECTION.

PASSENGERS,—	1911.			1910.		
	S.	R.	Total.	S.	R.	Total.
1st Class	1,089	1,572	2,661	996	1,894	2,890
2nd Class	8,441	13,748	22,189	8,864	16,690	25,554
<b>Total</b>	<b>9,530</b>	<b>15,320</b>	<b>24,850</b>	<b>9,860</b>	<b>18,584</b>	<b>28,444</b>

Season Tickets .. ..	470	547
<b>PARCELS, ETC.,—</b>	<b>No.</b>	<b>No.</b>
Parcels .. ..	2,157	2,148
Horses .. ..	27	40
Carriages .. ..	7	2
Dogs .. ..	84	51
<b>Total .. ..</b>	<b>2,275</b>	<b>2,241</b>

GOODS,—	No.	No.
Drays .. ..	5	2
Cattle .. ..	189	147
Calves .. ..	15	8
Sheep .. ..	1,070	959
Pigs .. ..	..	..
<b>Total .. ..</b>	<b>1,279</b>	<b>1,116</b>

	Tons.	Tons.
Chaff, Lime, &c. ..	156	150
Wool .. ..	1	1
Firewood .. ..	192	360
Timber .. ..	13,376	9,926
Grain .. ..	1,028	821
Merchandise .. ..	1,973	2,028
Minerals .. ..	31,127	29,626
<b>Total .. ..</b>	<b>47,853</b>	<b>42,912</b>

REVENUE,—	£ s. d.	£ s. d.
Passengers .. ..	1,879 19 2	2,020 14 2
Parcels, Luggage, & Mails	368 8 8	407 2 11
Goods .. ..	9,293 8 1	8,439 0 9
Miscellaneous .. ..	417 5 3	400 6 8
Rents and Commission	156 6 8	193 9 9
<b>Total .. ..</b>	<b>£12,115 7 10</b>	<b>£11,460 13 10</b>

WESTPORT SECTION.

PASSENGERS,—	1911.			1910.		
	S.	R.	Total.	S.	R.	Total.
1st Class	51	154	205	50	274	324
2nd Class	2,156	5,844	8,000	2,102	4,934	7,036
<b>Total</b>	<b>2,207</b>	<b>5,998</b>	<b>8,205</b>	<b>2,152</b>	<b>5,208</b>	<b>7,360</b>

Season Tickets .. ..	55	87
<b>PARCELS, ETC.,—</b>	<b>No.</b>	<b>No.</b>
Parcels .. ..	534	494
Horses .. ..	3	2
Carriages .. ..	1	..
Dogs .. ..	13	14
<b>Total .. ..</b>	<b>551</b>	<b>510</b>

GOODS,—	No.	No.
Drays .. ..	1	1
Cattle .. ..	..	3
Calves .. ..	..	19
Sheep .. ..	66	128
Pigs .. ..	10	..
<b>Total .. ..</b>	<b>77</b>	<b>151</b>

WESTPORT SECTION—*continued.*

GOODS— <i>continued.</i>	1911.	1910.
	Tons.	Tons.
Chaff, Lime, &c. ..	48	54
Wool .. ..	..	..
Firewood .. ..	736	480
Timber .. ..	293	284
Grain .. ..	264	219
Merchandise .. ..	369	419
Minerals .. ..	63,974	56,503
<b>Total .. ..</b>	<b>65,684</b>	<b>57,959</b>

REVENUE,—	£ s. d.	£ s. d.
Passengers .. ..	510 19 4	483 16 6
Parcels, Luggage, & Mails	77 8 2	61 9 7
Goods .. ..	8,620 1 9	7,787 19 4
Miscellaneous .. ..	494 0 3	384 1 2
Rents and Commission	62 17 5	65 9 5
<b>Total .. ..</b>	<b>£9,765 6 11</b>	<b>£8,782 16 0</b>

NELSON SECTION.

PASSENGERS,—	1911.			1910.		
	S.	R.	Total.	S.	R.	Total.
1st Class	157	306	463	145	282	427
2nd Class	2,512	3,544	6,056	2,494	3,672	6,166
<b>Total</b>	<b>2,669</b>	<b>3,850</b>	<b>6,519</b>	<b>2,639</b>	<b>3,954</b>	<b>6,593</b>

Season Tickets .. ..	42	47
<b>PARCELS, ETC.,—</b>	<b>No.</b>	<b>No.</b>
Parcels .. ..	396	408
Horses .. ..	7	7
Carriages .. ..	..	1
Dogs .. ..	30	22
<b>Total .. ..</b>	<b>433</b>	<b>438</b>

GOODS,—	No.	No.
Drays .. ..	2	4
Cattle .. ..	5	15
Calves .. ..	..	3
Sheep .. ..	10	270
Pigs .. ..	..	..
<b>Total .. ..</b>	<b>17</b>	<b>292</b>

	Tons.	Tons.
Chaff, Lime, &c. ..	168	162
Wool .. ..	3	8
Firewood .. ..	306	300
Timber .. ..	412	399
Grain .. ..	501	650
Merchandise .. ..	270	338
Minerals .. ..	642	782
<b>Total .. ..</b>	<b>2,302</b>	<b>2,639</b>

REVENUE,—	£ s. d.	£ s. d.
Passengers .. ..	445 11 11	426 16 8
Parcels, Luggage, & Mails	91 0 11	89 19 0
Goods .. ..	967 5 6	1,156 5 3
Miscellaneous .. ..	56 10 11	95 17 10
Rents and Commission	141 2 6	99 11 0
<b>Total .. ..</b>	<b>£1,701 11 9</b>	<b>£1,868 9 9</b>

PICTON SECTION.

PASSENGERS,—	1911.			1910.		
	S.	R.	Total.	S.	R.	Total.
1st Class	658	2,296	2,954	562	2,092	2,654
2nd Class	1,940	4,918	6,858	1,844	4,720	6,564
<b>Total</b>	<b>2,598</b>	<b>7,214</b>	<b>9,812</b>	<b>2,406</b>	<b>6,812</b>	<b>9,218</b>

Season Tickets .. ..	16	44
<b>PARCELS, ETC.,—</b>	<b>No.</b>	<b>No.</b>
Parcels .. ..	309	239
Horses .. ..	50	46
Carriages .. ..	2	1
Dogs .. ..	70	55
<b>Total .. ..</b>	<b>431</b>	<b>341</b>

GOODS,—	No.	No.
Drays .. ..	1	1
Cattle .. ..	12	13
Calves .. ..	16	..
Sheep .. ..	665	583
Pigs .. ..	..	..
<b>Total .. ..</b>	<b>694</b>	<b>597</b>

	Tons.	Tons.
Chaff, Lime, &c. ..	696	1,218
Wool .. ..	6	6
Firewood .. ..	168	144
Timber .. ..	188	259
Grain .. ..	641	712
Merchandise .. ..	603	467
Minerals .. ..	739	356
<b>Total .. ..</b>	<b>3,041</b>	<b>3,162</b>

PICTON SECTION—continued.

	1911.			1910.		
REVENUE,—	£	s.	d.	£	s.	d.
Passengers ..	713	5	1	596	1	11
Parcels, Luggage, & Mails	110	12	5	84	1	8
Goods ..	845	0	9	772	7	4
Miscellaneous ..	75	12	11	70	17	11
Rents and Commission	101	19	3	90	15	3
<b>Total ..</b>	<b>£1,846</b>	<b>10</b>	<b>5</b>	<b>£1,614</b>	<b>4</b>	<b>1</b>

LAKE WAKATIPU STEAMERS.

PASSENGERS,—	1911.			1910.		
	S.	R.	Total.	S.	R.	Total.
1st Class	102	166	268	114	128	242
2nd Class	163	132	295	197	118	315
<b>Total ..</b>	<b>265</b>	<b>298</b>	<b>563</b>	<b>311</b>	<b>246</b>	<b>557</b>
Season Tickets ..			0			0

PARCELS, ETC.,—	1911.		1910.	
	No.	No.	No.	No.
Parcels ..	379	430		
Horses ..	14	10		
Carriages ..	3	15		
Dogs ..	3	15		
<b>Total ..</b>	<b>399</b>	<b>455</b>		

Railway Department, 14th November, 1911.

LAKE WAKATIPU STEAMERS—continued.

Goods,—	1911.		1910.	
	No.	No.	No.	No.
Drays ..	2	..	..	..
Cattle ..	10	..	8	..
Calves ..	..	..	..	..
Sheep ..	108	..	130	..
Pigs ..	..	..	25	..
<b>Total ..</b>	<b>120</b>	<b>..</b>	<b>163</b>	<b>..</b>

	1911.		1910.	
	Tons.	Tons.	Tons.	Tons.
Chaff, Lime, &c. ..	36	24	..	..
Wool ..	13	4	..	..
Firewood ..	6	..	..	..
Timber ..	37	47	..	..
Grain ..	232	168	..	..
Merchandise ..	175	136	..	..
Minerals ..	66	119	..	..
<b>Total ..</b>	<b>565</b>	<b>498</b>	<b>..</b>	<b>..</b>

REVENUE,—	1911.			1910.		
	£	s.	d.	£	s.	d.
Passengers ..	90	2	3	145	2	6
Parcels, Luggage, & Mails	65	6	4	63	10	4
Goods ..	208	8	0	192	2	6
Miscellaneous ..	Cr. 0	0	7	Cr. 0	3	4
Rents and Commission	..	..	..	2	10	0
<b>Total ..</b>	<b>£363</b>	<b>16</b>	<b>0</b>	<b>£403</b>	<b>2</b>	<b>0</b>

H. DAVIDSON,  
Chief Accountant, New Zealand Railways.

N.Z.R.—FINANCIAL YEAR 1911-12.

RAILWAY WORKING ACCOUNT, showing the REVENUE and EXPENDITURE to the Termination of the Period ending 14th October, 1911.

Section.	Miles open for Traffic.	REVENUE.		EXPENDITURE.		FOR A TWELVE-MONTHLY PERIOD, AVERAGE TO DATE.		
		Four-weekly.	Total to Date.	Four-weekly.	Total to Date.	Per Cent. of Revenue.	Revenue per Mile of Railway.	Expenditure per Mile of Railway.
<b>NORTH ISLAND.—</b>								
Whangarei-Kawakawa	58	2,710 8 2	17,550 18 2	2,481 10 7	14,134 12 10	80.54	596 10 0	480 7 10
Kaihu ..	17	320 11 11	1,972 19 11	340 5 5	2,641 11 1	133.89	215 10 9	288 11 6
Gisborne ..	23	1,076 3 3	7,002 7 4	812 8 9	4,627 4 2	66.08	565 8 2	373 12 6
North Island Main Lines and Branches	1,075	131,625 15 2	927,352 12 2	91,769 18 6	623,612 10 2	67.25	1,602 1 5	1,077 6 10
<b>Total ..</b>	<b>1,173</b>	<b>135,732 18 6</b>	<b>953,878 17 7</b>	<b>95,404 3 3</b>	<b>645,015 18 3</b>	<b>67.62</b>		
<b>SOUTH ISLAND.—</b>								
South Island Main Lines and Branches	1,357	96,997 4 4	740,550 19 3	76,222 16 6	512,618 5 7	69.22	1,018 12 10	705 2 2
Westland ..	141	12,115 7 10	84,002 11 0	6,345 18 7	44,658 17 9	53.16	1,106 8 5	588 4 3
Westport ..	31	9,765 6 11	64,281 7 3	3,960 2 8	28,923 7 9	45.00	3,850 19 3	1,732 14 10
Nelson ..	48	1,701 11 9	12,575 8 6	1,413 8 3	10,930 12 11	86.92	486 11 0	422 18 3
Picton ..	48	1,846 10 5	13,352 10 8	2,303 10 7	13,770 19 0	103.13	527 12 2	544 2 10
Lake Wakatipu Steamers	..	363 16 0	2,913 11 3	532 3 10	2,734 6 10	93.85		
<b>Total ..</b>	<b>1,625</b>	<b>122,789 17 3</b>	<b>917,676 7 11</b>	<b>90,778 0 5</b>	<b>613,636 9 10</b>	<b>66.87</b>		
<b>Grand total ..</b>	<b>2,798</b>	<b>258,522 15 9</b>	<b>1,871,555 5 6</b>	<b>186,182 3 8</b>	<b>1,258,652 8 1</b>	<b>67.25</b>		

CORRESPONDING PERIOD LAST YEAR.

Section.	Miles open for Traffic.	REVENUE.		EXPENDITURE.		Per Cent. of Revenue.	Revenue per Mile of Railway.	Expenditure per Mile of Railway.
		£ s. d.	£ s. d.	£ s. d.	£ s. d.			
<b>NORTH ISLAND.—</b>								
Whangarei-Kawakawa	35	2,430 15 3	16,158 8 8	1,558 13 3	10,251 9 4	63.44	871 12 4	552 19 8
Kaihu ..	17	264 11 3	1,909 13 6	569 8 5	2,617 8 6	137.06	208 12 5	285 18 9
Gisborne ..	23	1,091 6 3	6,154 8 4	770 17 1	7,267 0 7	118.08	496 18 10	586 15 7
North Island Main Lines and Branches	1,075	121,371 19 4	854,133 18 10	83,973 6 7	581,484 19 6	68.08	1,480 11 0	1,007 18 10
<b>Total ..</b>	<b>1,150</b>	<b>125,158 12 1</b>	<b>878,356 9 4</b>	<b>86,872 5 4</b>	<b>601,620 17 11</b>	<b>68.49</b>		
<b>SOUTH ISLAND.—</b>								
South Island Main Lines and Branches	1,334	95,155 18 7	709,444 13 0	66,914 12 7	504,052 4 7	71.05	994 4 2	706 7 3
Westland ..	141	11,460 13 10	76,511 6 3	6,161 11 8	43,874 12 5	57.34	1,020 18 8	585 8 11
Westport ..	31	8,782 16 0	66,375 0 4	4,176 0 8	29,110 6 6	43.86	3,976 7 10	1,743 18 9
Nelson ..	48	1,868 9 9	12,343 5 7	1,439 1 3	10,702 18 5	86.71	477 11 4	414 2 0
Picton ..	34	1,614 4 1	12,941 8 8	1,837 10 2	13,417 11 2	103.68	706 17 8	732 17 10
Lake Wakatipu Steamers	..	403 2 0	2,668 12 4	523 17 10	2,628 18 1	98.51		
<b>Total ..</b>	<b>1,588</b>	<b>119,285 4 3</b>	<b>880,284 6 2</b>	<b>81,052 14 2</b>	<b>603,786 11 2</b>	<b>68.34</b>		
<b>Grand total ..</b>	<b>2,738</b>	<b>244,443 16 4</b>	<b>1,758,640 15 6</b>	<b>167,924 19 6</b>	<b>1,205,407 9 1</b>	<b>68.54</b>		

Railway Department, 14th November, 1911.

H. DAVIDSON,  
Chief Accountant, New Zealand Railways.

COMPARATIVE STATEMENT of TRAFFIC on ALL SECTIONS from 1st April, 1911, to 14th October, 1911.

All Sections.	Passengers.			Season Tickets.	Number.					Number.							
	First Class.	Second Class.	Total.		Total.	Parcels.	Horses.	Carriages.	Dogs.	Total.	Drays, &c.	Cattle.	Calves.	Sheep.	Pigs.	Total.	
1911	S. 238,631	R. 665,387	1,296,895	3,397,790	5,598,203	129,212	574,108	9,579	1,306	31,382	616,375	1481	103,055	12,338	2,270,139	62,217	2,449,230
1910	231,152	609,618	1,291,540	3,081,834	5,214,144	119,098	548,375	9,145	1,331	29,049	587,900	1216	108,986	9,534	2,422,148	71,376	2,613,260
Inc.	7,479	55,769	4,855	315,956	384,059	10,114	25,733	434	..	2,333	28,475	265	..	2,804	..	..	..
Dec.	..	..	..	..	..	..	..	..	25	..	..	..	5,931	..	152,009	9,159	164,030

All Sections.	Tons.													
	Chaff, Lime, &c.		Wool.		Firewood.		Timber.		Grain.		Merchandise.	Minerals.	Total.	
1911 ..	Tons	c. qr.	Tons	c. qr.	Tons	c. qr.	Tons	c. qr.	Tons	c. qr.	Tons	c. qr.	Tons	c. qr.
1910 ..	117,534	0 0	25,181	8 0	66,746	0 0	394,596	7 0	542,795	14 0	426,223	14 0	1,466,975	14 0
Increase	..	..	..	..	3,463	0 0	67,866	12 0	..	..	..	..	..	2,672
Decrease	854	0 0	245	8 0	..	..	..	..	17,429	0 0	941	5 0	49,187	16 0

ESTIMATED COST of CONSTRUCTION of RAILWAYS, ROLLING-STOCK, &amp;c., to 31st March, 1911, as furnished by Public Works Department and by Greymouth and Westport Harbour Boards respectively.

Section.	Cost of Opened Lines.		Cost of Unopened Lines.	
	£	s. d.	£	s. d.
Kawakawa .. .. .	93,290	0 0	105,321	0 0
Whangarei .. .. .	223,998	0 0	141,432	0 0
Kaibu .. .. .	67,918	0 0	2,327	0 0
Gisborne .. .. .	197,322	0 0	181,346	0 0
North Island Main Lines and Branches .. .. .	12,903,629	0 0	312,458	0 0
South Island Main Lines and Branches .. .. .	13,045,004	0 0	276,835	0 0
Westland .. .. .	1,694,783	0 0	440,024	0 0
Westport .. .. .	518,014	0 0	76,758	0 0
Nelson .. .. .	404,030	0 0	87,923	0 0
Picton .. .. .	390,032	0 0	149,819	0 0
Lake Wakatipu Steamer Service .. .. .	16,436	0 0	..	..
In Suspense—				
Surveys, North Island .. .. .	..	..	32,424	0 0
Miscellaneous, North Island .. .. .	..	..	5,169	0 0
Surveys, South Island .. .. .	..	..	8,472	0 0
Miscellaneous, South Island .. .. .	..	..	5,168	0 0
F.W.D. Stock of Permanent-way .. .. .	..	..	77,938	0 0
W.R.D. Stock of A.O.L. Stores .. .. .	..	..	..	..
W.R.D. Deposit Account for Permanent-way Material .. .. .	27,090	0 0	..	..
W.R.D. Deposit Account for Permanent-way Material .. .. .	25,000	0 0	..	..
Totals .. .. .	£29,606,546	0 0	£1,903,414	0 0

H. DAVIDSON,  
Chief Accountant, New Zealand Railways.

Railway Department, 14th November, 1911.

Population of the Dominion.

RETURN of the Estimated Population of the Dominion of New Zealand on the 30th September, 1911.

	Males.	Females.	Total.
Population (excluding Maoris and residents of Cook and other Pacific islands), 30th June, 1911 .. .. .	531,662	477,830	1,009,492
Increase during September quarter, 1911—			
	Males.	Females.	Total.
By Births .. .. .	3,413	3,208	6,621
„ Arrivals .. .. .	5,719	3,466	9,185
	9,132	6,674	15,806
Decrease during September quarter, 1911—			
	Males.	Females.	Total.
By Deaths .. .. .	1,584	1,118	2,702
„ Departures .. .. .	5,500	2,835	8,335
	7,084	3,953	11,037
Net increase during September quarter, 1911 .. .. .	2,048	2,721	4,769
Estimated population (exclusive of Maoris, &c.) on 30th September, 1911 .. .. .	533,710	480,551	1,014,261
Maori population, Census, 1911 .. .. .	26,475	23,369	49,844
Population of Cook and other Pacific islands, Census, 1906 (1911 figures not yet available) ..	6,224	6,116	*12,340
Total estimated population of the Dominion on 30th September, 1911 .. .. .	566,409	410,036	1,076,445

\* Excluding 776 Natives of South Sea Islands at labour abroad.

Registrar-General's Office,  
Wellington, 13th November, 1911.

M. FRASER,  
Government Statistician.

Immigration and Emigration Returns.

RETURN of IMMIGRATION to and EMIGRATION from the DOMINION of NEW ZEALAND during the MONTH of SEPTEMBER, 1911, showing the Places from which Persons arrived and to which they departed, and the Ports of Arrival and Departure.

ARRIVALS AND DEPARTURES FROM AND TO DIFFERENT PLACES.

Countries.	ARRIVALS.					DEPARTURES.				
	Adults.		Children.		Total Persons.	Adults.		Children.		Total Persons.
	M.	F.	M.	F.		M.	F.	M.	F.	
United Kingdom .. .. .	451	307	99	90	937	28	15	5	5	53
Queensland .. .. .	..	..	..	..	..	3	1	..	1	5
Victoria .. .. .	144	73	11	7	235	149	73	12	8	242
New South Wales .. .. .	989	587	75	72	1,723	1,181	650	101	85	2,017
Western Australia .. .. .	..	..	..	..	..	..	..	..	..	..
South Australia .. .. .	..	..	..	..	..	..	..	..	..	..
Tasmania .. .. .	52	19	4	1	76	22	9	1	..	32
Fiji .. .. .	40	41	4	5	90	85	7	2	..	94
Other British possessions .. .. .	226	65	12	10	313*	182	94	17	17	310†
Pacific Islands .. .. .	26	16	2	1	45‡	61	36	4	1	102§
Other foreign ports .. .. .	49	11	5	1	66	53	6	1	..	60¶
Totals, September, 1911 .. .. .	1,977	1,119	212	177	3,485	1,764	891	143	117	2,915
Totals, September, 1910 .. .. .	1,515	824	113	139	2,591	1,362	699	103	95	2,259

\* From Bengal, 61; Singapore, 26; British Columbia, 217; Cape Town, 9. † For British Columbia, 300; Norfolk Island, 9; Calcutta, 1.  
‡ From Friendly Islands, 15; Society Islands, 8; Sandwich Islands, 22. § For Friendly Islands, 9; Society Islands, 27; Sandwich Islands, 61; Navigator Islands, 5. || From San Francisco, 64; Tenerife, 2. ¶ For San Francisco, 29; Monte Video, 31.

ARRIVALS AT AND DEPARTURES FROM DIFFERENT NEW ZEALAND PORTS.\*

Ports.	ARRIVALS.					DEPARTURES.				
	Adults.	Children.	Males.	Females.	Total Persons.	Adults.	Children.	Males.	Females.	Total Persons.
Auckland .. .. .	1,253	121	879	495	1,374	1,274	124	918	480	1,398
Wellington .. .. .	1,561	248	1,106	703	1,809	1,123	113	800	436	1,236
Dunedin .. .. .	33	..	24	9	33	1	..	..	1	1
Invercargill .. .. .	249	20	180	89	269	257	23	189	91	280
Totals, September, 1911 .. .. .	3,096	389	2,189	1,296	3,485	2,665	260	1,907	1,008	2,915
Totals, September, 1910 .. .. .	2,339	252	1,628	963	2,591	2,061	198	1,465	794	2,259
Chinese: Arrivals—					Chinese: Departures—					
			Males.	Females.				Males.	Females.	
At Auckland .. .. .	..	..	23	1	From Auckland .. .. .	..	..	24	1	
„ Wellington .. .. .	..	..	14	2	„ Wellington .. .. .	..	..	16	..	
Total arrivals .. .. .	..	..	37	3	Total departures .. .. .	..	..	40	1	

\* It is important to mention that, in the returns from which this table is made up, immigrants to the Dominion are all counted at the first port of arrival, and emigrants at the final port of departure.

Registrar-General's Office,  
Wellington, 13th November, 1911.

M. FRASER,  
Government Statistician.

## Census, 1911.

Registrar-General's Office, Wellington, 15th November, 1911.

THE accompanying table, showing the result of the Census taken in April, 1911, as regards poultry and bee-keeping, is published for general information.

M. FRASER,  
Government Statistician.

TABLE showing the NUMBER of POULTRY of Various Kinds in New Zealand, also the NUMBER of BEE-KEEPERS and HIVES, with the QUANTITY of HONEY and WAX produced during the Year, as ascertained at the Census of 2nd April, 1911.

Provincial District.	Geese.	Ducks.	Fowls.	Turkeys.	Other Poultry.	Total Poultry.	No. of Persons keeping Bees.	No. of Bee-hives.	Honey produced during Year.	Beeswax produced during Year.
									Lb.	Lb.
Auckland..	5,044	107,177	783,363	40,103	2,295	937,982	2,441	17,455	399,703	9,022
Taranaki ..	3,014	21,332	158,450	6,750	429	189,975	782	4,556	122,189	1,989
Hawke's Bay ..	2,157	18,760	171,009	7,798	707	200,431	554	3,456	37,170	958
Wellington ..	10,406	65,684	504,090	17,025	690	597,895	1,561	13,228	358,710	4,436
Marlborough ..	1,941	5,583	64,846	2,413	58	74,841	354	1,482	22,023	325
Nelson ..	2,971	15,431	184,636	3,053	326	206,417	644	2,887	71,186	1,610
Westland ..	990	4,369	36,186	84	25	41,654	121	531	8,495	113
Canterbury ..	8,529	48,957	679,835	9,719	793	747,833	2,351	15,014	237,844	5,087
Otago—										
Otago portion ..	6,210	25,698	428,899	9,289	218	470,314	1,269	7,583	114,912	2,038
Southland portion ..	4,049	16,172	202,731	1,650	13	224,615	925	5,392	85,040	2,483
Totals ..	45,311	329,163	3,214,045	97,884	5,554*	3,691,957	11,002	71,584	1,457,272	28,061
Census, 1906 ..	44,300	281,999	2,784,269	77,101	3,935	3,191,604	15,396	74,341	1,003,940	31,682

\* 3,772 guinea-fowls, 915 pheasants, 29 ostriches, 3 emus, and 835 not specified.

NOTE.—Taking 5d. per lb. for the honey and 1s. 3d. per lb. for the wax, the value of the output for the year would amount to £32,113 12s. 11d.—viz., £30,359 16s. 8d. for honey, and £1,753 16s. 3d. for wax.

Officiating Ministers for 1911.—Notice No. 37.

Registrar-General's Office,  
Wellington, 15th November, 1911.

PURSUANT to the provisions of an Act of the General Assembly of New Zealand passed in the eighth year of the reign of His late Majesty King Edward VII, and intitled the Marriage Act, 1908, the following name of an Officiating Minister within the meaning of the said Act is published for general information:—

*Baptists.*

The Reverend WILLIAM BARNETT.

[Erratum.—In Notice No. 16, Officiating Ministers for 1911, on page 1364 of Gazette of 20th April, 1911, Methodist Church of Australasia in New Zealand, for "Mr. A. Parsons" read "Mr. J. E. Parsons."]

W. W. COOK,  
Deputy Registrar-General.

Notice to Persons in whom is vested Ecclesiastical Authority over Religious Bodies.

Registrar-General's Office,  
Wellington, 11th November, 1911.

THE attention of the persons or person within the Dominion of New Zealand in whom is vested ecclesiastical authority over any of the religious bodies enumerated in the Third Schedule annexed to an Act of the General Assembly of New Zealand intitled the Marriage Act, 1908, and of all other persons concerned, is directed to the 11th section of the above-mentioned Act, requiring the several ecclesiastical authorities as aforesaid to send in to the Registrar-General, in the month of December in every year, a correct list of their Officiating Ministers within the meaning of the Marriage Act, 1908, of each of the said religious bodies.

The following are the religious bodies above referred to:—

- The Church of the Province of New Zealand, commonly called the Church of England.
- The Presbyterian Church of New Zealand.
- The Roman Catholic Church.
- The Methodist Church of Australasia in New Zealand.
- All Congregational Independents.

*Baptists.*

The Primitive Methodist Connexion.  
The Lutheran Church.  
All Hebrew Congregations.  
The Society of Friends.

In default of any person having ecclesiastical authority over any of the religious bodies named above, the name of the Officiating Minister of any congregation of such religious body may be certified to by two recognized office-bearers thereof.

A minister of religion not connected with any of the aforesaid bodies must send to the Registrar-General in the month of December in each year a certificate signed—

- (a.) By the recognized head in New Zealand of the religious body to which he belongs; or
- (b.) By two duly recognized ministers of such religious body; or
- (c.) By ten adult members thereof, who append their signatures their description as being such members, declaring that such minister is their Officiating Minister, the said signatures and descriptions being attested by some person who shall verify the signatures to the certificate as the genuine signatures of the persons whose they purport to be, by a statutory declaration signed by such person and appended to the certificate.

Neglect in sending the certificate will deprive the minister of his status as an Officiating Minister under the Marriage Act.

N.B.—It is requested that the *Christian names* and the *addresses* of the several ministers may be specified in the lists sent in to the Registrar-General.

W. W. COOK,  
Deputy Registrar-General.

*Friendly Society registered.*

The Treasury, New Zealand,  
Friendly Societies Office,  
Wellington, 8th November, 1911.

THE Grey Valley Coal-miners' Medical Fund Society, situated at Brunnerton, is registered as a friendly society under the Friendly Societies Act, 1909, this 8th day of November, 1911.

ROBT. E. HAYES,  
Registrar of Friendly Societies.

CROWN LANDS NOTICES.

Lands in Auckland Land District forfeited.

Department of Lands, Wellington, 14th November, 1911.

NOTICE is hereby given that, the leases and licenses of the undermentioned lands having been forfeited by resolution of the Auckland Land Board, the said lands have thereby reverted to the Crown under the provisions of the Land Act, 1908.

SCHEDULE.

AUCKLAND LAND DISTRICT.

Tenure.	Lease or License No.	Section.	Block.	District.	Formerly held by	Reason for Forfeiture.
R.L.	259	1	I	Lichfield Village ..	J. B. Maunder ..	Selector's request.
M.D.L.O.	90	3	VIII	Tairua ..	R. Hepetema ..	Arrears of rent.
O.R.P.	3581	54	II	Whangape ..	W. Hume ..	Abandoned.
"	3725	39	III	" ..	J. B. Brown ..	"
"	2493	8	V	Opuawhanga ..	T. H. Roxburgh ..	Deficient improvements and arrears of rent.
"	3801	30	X	Thames ..	S. B. Povey ..	Deficient improvements.
"	3726	1	"	Tutamoe ..	C. A. Mills and T. Meggitt	Abandoned.
"	3820	3	I	Waihou ..	Jno. Williams ..	"
"	3844	1	V	" ..	H. Clark ..	Selector's request.
"	3997	84	Parish	Ruakaka ..	M. Jurakovich ..	Abandoned.
"	2754	87	"	Mangonui East ..	S. Wrathall ..	Deficient improvements.
"	3937	8	XVI	Waoku ..	J. H. Sheehan ..	Selector's request.
"	3694	N.W. 25	Parish	Omanaia ..	S. A. Janett ..	Deficient improvements and non-residence.

D. BUDDO,  
For Minister of Lands.

Land in Taranaki Land District for Sale by Public Auction.

District Lands Office,  
New Plymouth, 15th November, 1911.

NOTICE is hereby given that the undermentioned land will be offered for sale by public auction, for cash, at this office, at 11 o'clock a.m., on Wednesday, the 20th day of December, 1911, under the provisions of the Land Act, 1908.

SCHEDULE.

TARANAKI LAND DISTRICT.—OHURA COUNTY.—OHURA SURVEY DISTRICT.

Rural Land.

Section.	Block.	Area.	Upset Price.
3	XV	A. R. P. 358 0 0	£ s. d. 1,408 10 0

The improvements, which are included in the upset price, consist of the following: 55 acres felled only, £68 15s.; 105 acres felled and grassed, £52 10s.; 5 chains wire netting on posts, 12s. 6d.; 101 chains fencing, £84 7s.; 58 chains fencing-wire on posts at homestead, £4 7s.; house, £90; whare, £15; pataka, £5: total, £320 11s. 6d.

The section is situated on the Aorangi Road, about a mile and three-quarters by good horse-track from Aukopae Landing, Wanganui River, which is about sixteen miles from Taumarunui by the river. There is also access from Taumarunui by a good horse-track, about twenty miles.

The section comprises flat, easy sloping, and rather steep country. The soil is of good quality generally, on papa formation. The forest is varied, ranging from fern and manuka to heavy bush consisting of rata, tawa, totara, rimu, miro, matai, white-pine, hinau, tawhero, &c., with a fairly dense undergrowth of supplejack, raureka, punga, and other soft woods and ferns. The section is well watered. Elevation ranges from 600 ft. to 1,200 ft. above sea-level.

WILLIAM ARMSTRONG,  
Commissioner of Crown Lands.

Reserves in Canterbury Land District for Lease by Public Tender.

District Lands Office,  
Christchurch, 11th November, 1911.

NOTICE is hereby given that written tenders will be received at this office up to 4 o'clock p.m. on Tuesday, the 19th day of December, 1911, for leases of the undermentioned reserves under the provisions of the Public Reserves and Domains Act, 1908.

SCHEDULE.

CANTERBURY LAND DISTRICT.

Reserve.	Block.	Survey District.	Area.	Minimum Annual Rental.	Term of Lease.
1264A	VIII	Burke ..	14 3 3	£ s. d. 6 0 0	7 years.
Part 394	..	Bealey ..	7 0 0*	20 0 0	3 years.

Reserve 1264A is situated at Burke's Pass, and known as the Police Reserve, and comprises land of good quality, and well sheltered on the west and south-west sides.

Part Reserve 394 is situated at Bealey, known as a Police Reserve, and bounds the Post-office Reserve, and is situated a few chains to the eastward of the Bealey Hotel, fronting the main road. There are some old buildings on the reserve.

\* About.

TERMS AND CONDITIONS OF LEASE.

- Tenders should be addressed to the Commissioner of Crown Lands, Christchurch, and indorsed on the outside "Tender for Lease of Reserve." One year's rent at the rate offered, together with £1 ls. lease fee, must accompany each tender.
- Possession will be given on acceptance of tender.
- Possession of the land comprised in the lease, or any portion thereof, may be resumed at any time by giving to the lessee twelve months' notice of intention so to do.
- The lessee shall have no right to compensation either for any improvements that may be placed upon the land, or on account of the aforesaid resumption, or for any other

cause; but he will be allowed, on the expiration of his lease, or in the event of the land being resumed as hereinbefore provided, to remove any fencing or buildings erected by him upon the land.

5. The lessee shall have no right to sublet, transfer, or otherwise dispose of the whole or any portion of the land comprised in the lease, without consent.

6. The land shall be used for grazing purposes only, and shall not be broken up or cropped without the written consent of the Commissioner of Crown Lands first had and obtained.

7. The lessee shall destroy all rabbits on the land, and shall prevent their increase or spread, to the satisfaction of the Commissioner of Crown Lands.

8. The lessee shall prevent the growth and spread of gorse, broom, and sweetbriar on the land comprised in the lease; and he shall with all reasonable despatch remove, or cause to be removed, all gorse, sweetbriar, broom, or other noxious weeds or plants as may be directed by the Commissioner of Crown Lands.

9. The lessee will be required, during each of the first three years of the term, to thoroughly clear of gorse and other noxious weeds not less than one-third of the area comprised in his lease, so that the whole of the area shall be thoroughly cleared at the expiration of the third year of the term, and thereafter be kept clear during the remainder of the term.

10. The rent shall be payable half-yearly in advance, free from all deductions whatsoever.

11. The lease shall be liable to forfeiture in case the lessee shall fail to fulfil any of the conditions of the said lease within thirty days after the date on which the same ought to be fulfilled.

T. N. BRODRICK,  
Commissioner of Crown Lands.

*Lands in Southland Land District open for Selection on Renewable Lease.*

District Lands Office,  
Invercargill, 14th November, 1911.

NOTICE is hereby given, in pursuance of section 326 of the Land Act, 1908, that the undermentioned lands are open for selection on renewable lease; and applications will be received at this office up to 4 o'clock p.m. on Wednesday, the 21st day of February, 1912.

SCHEDULE.

SOUTHLAND LAND DISTRICT.—WALLACE COUNTY.—LONGWOOD SURVEY DISTRICT.—OTAGO MINING DISTRICT.  
*Second-class Land.*

Section.	Block.	Area.			Capital Value.		Half-yearly Rental.			
		A.	R.	P.	£	s.	d.	£	s.	d.
5	XII	246	0	0	160	0	0	3	4	0
6	"	203	3	0	160	0	0	3	4	0
7	"	227	2	0	120	0	0	2	8	0

H. M. SKEET,  
Commissioner of Crown Lands.

*Land in Marlborough Land District for Disposal under Section 129 of the Land Act, 1908.*

District Lands Office,  
Blenheim, 9th October, 1911.

NOTICE is hereby given, in pursuance of section 326 of the Land Act, 1908, that the undermentioned land will be disposed of under section 129 of the said Act on or after Friday, the 12th day of January, 1912.

SCHEDULE.

MARLBOROUGH LAND DISTRICT.—WAKAMARINA SURVEY DISTRICT.

Section.	Block.	Area.		
		A.	R.	P.
21	IX	549	0	0
25	"	310	0	0

W. H. SKINNER,  
Commissioner of Crown Lands.

*Lands in Auckland Land District open for Selection on Renewable Lease.*

District Lands Office,  
Auckland, 21st September, 1911.

NOTICE is hereby given, in pursuance of section 326 of the Land Act, 1908, that the undermentioned lands are open for selection on renewable lease; and applications will be received at this office up to 4 o'clock p.m. on Monday, the 18th day of December, 1911.

SCHEDULE.

AUCKLAND LAND DISTRICT.—HOKIANGA COUNTY.—WAKOBU SURVEY DISTRICT.

*Second-class Unsurveyed Land.*

National Endowment.

Section.	Block.	Area.			Capital Value		Half-yearly Rental.			
		A.	R.	P.	£	s.	d.	£	s.	d.
2	V	660	0	0	620	0	0	12	8	0
3	"	783	0	0	580	0	0	11	12	0
1	VI	755	0	0	620	0	0	12	8	0
87	IX	560	0	0	320	0	0	6	8	0
88	"	570	0	0	530	0	0	10	12	0
21	X	594	0	0	440	0	0	8	16	0
22	"	350	0	0	270	0	0	5	8	0
23	"	730	0	0	540	0	0	10	16	0
24	"	765	0	0	570	0	0	11	8	0
25	"	772	0	0	570	0	0	11	8	0

ERIC C. GOLD SMITH,  
Commissioner of Crown Lands.

*Lands in Hawke's Bay Land District open for Sale or Selection.*

District Lands Office,  
Napier, 4th September, 1911.

NOTICE is hereby given, in pursuance of section 326 of the Land Act, 1908, that the undermentioned lands are open for sale or selection; and applications will be received at this office and at the local Lands Office, Gisborne, up to 4 o'clock p.m. on Thursday, the 7th day of December, 1911.

SCHEDULE.

HAWKE'S BAY LAND DISTRICT.

*Second-class Land.*

Section.	Block.	Area.	Cash Purchase: Total Price.	Occupation with Right of Purchase: Half-yearly Rent.	Renewable Lease: Half-yearly Rent.

WAIKAWA COUNTY.—MAKARETU SURVEY DISTRICT.

Section.	Block.	Area.			Cash Purchase: Total Price.		Occupation with Right of Purchase: Half-yearly Rent.		Renewable Lease: Half-yearly Rent.				
		A.	R.	P.	£	s.	d.	£	s.	d.			
6	III	93	3	20	600	0	0	15	0	0	12	0	0

WAIKOHU COUNTY.—WAIKOHU SURVEY DISTRICT.

Section.	Block.	Area.			Cash Purchase: Total Price.		Occupation with Right of Purchase: Half-yearly Rent.		Renewable Lease: Half-yearly Rent.				
		A.	R.	P.	£	s.	d.	£	s.	d.			
2	I	128	0	0	770	0	0	19	5	0	15	8	0

C. R. POLLEN,  
Commissioner of Crown Lands.

*Land in Wellington Land District for Disposal under Section 128 of the Land Act, 1908.*

District Lands Office,  
Wellington, 17th October, 1911.

NOTICE is hereby given in pursuance of section 326 of the Land Act, 1908, that Section 23, Block II, Maungakaretu Survey District, Wellington Land District, containing 25 acres, will be disposed of, under section 128 of the said Act, to the holder of adjoining land, on or after Thursday, the 18th day of January, 1912.

JAMES MACKENZIE,  
Commissioner of Crown Lands.



*Lands in Otago Land District open for Sale or Selection.*

District Lands Office,  
Dunedin, 27th September, 1911.

NOTICE is hereby given, in pursuance of section 326 of the Land Act, 1908, that the undermentioned lands are open for sale or selection; and applications will be received at this office up to 4 o'clock p.m. on Tuesday, the 9th day of January, 1912.

SCHEDULE.

OTAGO LAND DISTRICT.—CLUTHA COUNTY.—TAUTUKU SURVEY DISTRICT.

*Second-class Land.*

Section.	Block.	Area.	Cash Purchase: Total Price.	Occupation with Right of Purchase: Half-yearly Rent.	Renewable Lease: Half-yearly Rent.
		A. R. P.	£ s. d.	£ s. d.	£ s. d.
17	XI	84 2 7	50 0 0	1 5 0	1 0 0
18	"	51 2 32	30 0 0	0 15 0	0 12 0
19	"	88 1 0	50 0 0	1 5 0	1 0 0
20	"	84 2 0	50 0 0	1 5 0	1 0 0
21	"	89 2 31	50 0 0	1 5 0	1 0 0
22	"	54 2 0	30 0 0	0 15 0	0 12 0
23	"	86 1 14	50 0 0	1 5 0	1 0 0
24	"	89 0 15	50 0 0	1 5 0	1 0 0

E. H. WILMOT,  
Commissioner of Crown Lands.

*Milling-timber in Nelson Land District for Sale by Public Tender.*

District Lands Office,  
Nelson, 24th October, 1911.

NOTICE is hereby given, in terms of the Land Act, 1908, and regulations thereunder, that written tenders will be received at the District Lands Office, Nelson, up till 12 o'clock noon on Tuesday, the 28th day of November, 1911, for the purchase of the undermentioned timber.

SCHEDULE.

NELSON LAND DISTRICT.

*Section 27, Block VI, Wai-iti Survey District.*

	£	s.	d.
108,240 sup. ft. of matai, at 1s. per 100 feet ...	54	2	6
236,320 ,, birch, at 1s. ,, ...	118	3	3
80,200 ,, miro, at 6d. ,, ...	20	1	0
648,000 ,, rimu, at 6d. ,, ...	162	0	0
1,072,760 sup. ft.	Minimum price : £354 6 9		

CONDITIONS OF SALE.

(1.) The right to cut and remove the timber will be generally in accordance with the provisions of the Land Act, 1908, the Timber Regulations made thereunder, and the following conditions :—

- (a.) The tender must be accompanied by a deposit of 5 per cent. of the amount of such tender, together with £1 1s. license fee.
- (b.) The successful tenderer shall pay the purchase-money in three instalments: 10 per cent. on the acceptance of his tender; half of the balance at the end of three months, and the other half at the end of six months, from date of acceptance of tender.

(2.) The successful tenderer shall have the right to cut the timber during the period of one year from date of acceptance of tender.

(3.) The successful tenderer shall not put, throw, or place, or allow to be put, thrown, or placed, in any river, stream, or watercourse, or into any place where it may be washed into a stream, river, or watercourse, any sawdust or any refuse.

(4.) If no tender is received for the timber, the right to cut it at the upset price quoted in the Schedule above will remain open for application until further notice.

(5.) No compensation will be given, nor shall any be claimed, for any error, discrepancy, or misdescription whatsoever in respect to the lot or in these conditions.

(6.) The attention of intending purchasers is directed particularly to clauses 9, 17, 18, 22, and 27 of the "Timber Regulations," copies of which may be obtained on application.

ROBT. T. SADD,  
Commissioner of Crown Lands.

*Milling-timber in Nelson Land District for Sale by Public Tender.*

District Lands Office,  
Nelson, 24th October, 1911.

NOTICE is hereby given, in terms of the Land Act, 1908, and regulations thereunder, that written tenders will be received at the District Lands Office, Nelson, up till 12 o'clock noon on Tuesday, the 28th day of November, 1911, for the purchase of the undermentioned timber.

SCHEDULE.

NELSON LAND DISTRICT.

*Section 34, Block X, Wai-iti Survey District.*

	£	s.	d.
4,590 sup. ft. of matai, at 1s. per 100 feet ...	2	6	0
1,350 ,, matai, at 2s. ,, ...	1	7	0
96,440 ,, rimu, at 6d. ,, ...	24	2	3
5,280 ,, miro, at 6d. ,, ...	1	6	6
11,310 ,, birch, at 1s. ,, ...	5	13	0

118,970 sup. ft. Minimum price : £34 14 9

CONDITIONS OF SALE.

(1.) The right to cut and remove the timber will be generally in accordance with the provisions of the Land Act, 1908, the Timber Regulations made thereunder, and the following conditions :—

- (a.) The tender must be accompanied by a deposit of 5 per cent. of the amount of such tender, together with £1 1s. license fee.
- (b.) The successful tenderer shall pay the purchase-money in two instalments: 25 per cent. on the acceptance of tender, balance at the end of three months from date of acceptance of tender.

(2.) The successful tenderer shall have the right to cut the timber during a period of six months from date of acceptance of tender.

(3.) The successful tenderer shall not put, throw, or place, or allow to be put, thrown, or placed, in any river, stream, or watercourse, or into any place where it may be washed into a stream, river, or watercourse, any sawdust or any refuse.

(4.) If no tender is received for the timber, the right to cut it at the upset price quoted in the Schedule above will remain open for application until further notice.

(5.) No compensation will be given, nor shall any be claimed, for any error, discrepancy, or misdescription whatsoever in respect to the lot or in these conditions.

(6.) The attention of intending purchasers is directed particularly to clauses 9, 17, 18, 22, and 27 of the "Timber Regulations," copies of which may be obtained on application.

ROBT. T. SADD,  
Commissioner of Crown Lands.

*Land in Taranaki Land District for Disposal under Section 131 of the Land Act, 1908.*

District Lands Office,  
New Plymouth, 18th October, 1911.

NOTICE is hereby given, in pursuance of section 326 of the Land Act, 1908, that part of Section 8, Block VII, Waro Survey District, Taranaki Land District, containing about 7 acres 2 roods 21 perches, will be disposed of to the holder of adjoining land, under section 131 of the said Act, on or after Friday, the 26th day of January, 1912.

WILLIAM ARMSTRONG,  
Commissioner of Crown Lands.

*Reserves in Taranaki Land District for Lease by Public Tender.*

District Lands Office,  
New Plymouth, 9th October, 1911.

NOTICE is hereby given that written tenders for leases of the undermentioned lands will be received at the District Lands Office, New Plymouth, up to 4 o'clock p.m. on Wednesday, the 29th November, 1911, under the provisions of the Public Reserves and Domains Act, 1908.

SCHEDULE.

TARANAKI LAND DISTRICT.

Section.	Area.	Minimum Annual Rental.	Term of Lease.
<i>Block XV, Ngatimaru Survey District.</i>			
	A. R. P.	£ s. d.	
28	40 1 33	5 0 0	10 years.
<i>Block II, Heao Survey District.</i>			
1	101 1 0	5 1 0	Year to year.
<i>Block XIII, Ohura Survey District.</i>			
5	83 2 1	4 3 6	Year to year.

TERMS AND CONDITIONS OF LEASE.

1. Six months' rent at the rate offered, together with £1 ls. lease fee, must accompany each tender.

2. There are no restrictions or limitations as to the number of sections which one person may lease, and no declaration is required. Residence is not compulsory. No compensation shall be claimed by the lessee, nor shall any be allowed by the Government, on account of any improvements effected by the lessee, nor for any other cause.

3. The lease shall be subject to termination by twelve months' notice in the event of the land being required by the Government.

4. The rent shall be payable half-yearly in advance.

5. The lessee shall have no right to sublet, transfer, or otherwise dispose of the land comprised in the lease without consent.

6. The land shall not be cropped nor broken up, except with the written consent of the Commissioner of Crown Lands first had and obtained.

7. The lessee shall prevent the growth and spread of gorse, broom, and sweetbriar on the land comprised in the lease; and he shall with all reasonable despatch remove, or cause to be removed, all gorse, sweetbriar, broom, or other noxious weeds or plants, as may be directed by the Commissioner of Crown Lands.

8. The lease shall be liable to forfeiture if the lessee fails to fulfil any of the conditions of the said lease within thirty days after the date on which the same ought to be fulfilled.

9. The lessee of Section 28, Block XV, Ngatimaru Survey District, must, within six months from acceptance of tender, securely enclose with a cattle-proof fence the piece of native bush, containing about 5 acres, in the south-eastern corner of the section.

Full particulars may be ascertained and plans obtained at this office.

WILLIAM ARMSTRONG,  
Commissioner of Crown Lands.

*Part of Clifton Domain, Taranaki Land District, for Lease by Public Auction.*

District Lands Office,  
New Plymouth, 29th October, 1911.

NOTICE is hereby given that the undermentioned domain will be offered for lease by public auction, under the provisions of the Public Reserves and Domains Act, 1908, at the District Lands Office, New Plymouth, on Wednesday, the 29th day of November, 1911, at 11 o'clock a.m.

SCHEDULE.

TARANAKI LAND DISTRICT.—BLOCK VII, WAITARA SURVEY DISTRICT.—PART OF CLIFTON DOMAIN.

Section.	Area.	Upset Annual Rental.	Term.
Part 71	20 acres (approx.)	£ s. d. 10 0 0	14 years.

*Terms and Conditions of Lease.*

1. Lease fee, £1 ls., and half-year's rent shall be paid upon the fall of the hammer.

2. Possession will be given on day of sale.

3. The lease shall be for the term specified, but shall be subject to termination by twelve months' notice in the event of the land being required by the Government.

4. The rent shall be paid half-yearly in advance.

5. The lessee shall have no right to sublet, transfer, or otherwise dispose of the land comprised in the lease, except with the written consent of the Commissioner of Crown Lands first had and obtained.

6. The lessee will not be allowed to fell, cut down, or destroy in any way any tree or shrub that may be upon the reserve, and he must prevent stock from trespassing on the portion of the reserve containing bush.

7. A substantial fence of four wires, and five posts to the chain, with two battens between the posts, shall be erected by the lessee within six months from date of lease so as to sufficiently protect the native bush, in such manner and of such material as may be approved by the Commissioner of Crown Lands, and before any stock is turned into clearing. The exact boundary to be fenced will be pointed out by an officer of the Survey Department.

8. The lessee will at all times during the said term keep in good repair and condition, to the satisfaction of the Commissioner of Crown Lands, all hedges, fences, and gates in, upon, and about the said land, and shall so yield them up at the expiration of the term.

9. The lessee shall prevent the growth and spread of gorse, broom, and sweetbriar on the land comprised in the lease; and he shall with all reasonable despatch remove, or cause to be removed, all gorse, sweetbriar, broom, or other noxious weeds or plants, as may be directed by the Commissioner of Crown Lands.

10. The lease shall be liable to forfeiture in case the lessee should fail to fulfil any of the conditions of the said lease within thirty days after the date on which the same ought to be fulfilled.

11. The public shall at all times have the free right of ingress and egress over the land comprised in the lease for *bona fide* recreation, but no person shall trespass with dog or firearms on the said land.

12. No buildings shall be erected on any portion of the domain.

Full particulars may be ascertained at this office.

WILLIAM ARMSTRONG,  
Commissioner of Crown Lands.

*Land in Otago Land District for Disposal under Section 138 of the Land Act, 1908.*

District Lands Office,  
Dunedin, 6th November, 1911.

NOTICE is hereby given, in pursuance of section 326 of the Land Act, 1908, that the undermentioned land will be disposed of to the holder of the adjoining land, under section 138 of the said Act, on or after Friday, the 9th day of February, 1912.

SCHEDULE.

OTAGO LAND DISTRICT.

SECTION 22, Block III, Tautuku Survey District, containing 149 acres 3 roods 4 perches.

E. H. WILMOT,  
Commissioner of Crown Lands.

*Milling-timber in Auckland Land District for Sale by Public Tender.*

District Lands Office,  
Auckland, 28th October, 1911.

NOTICE is hereby given, in terms of the Land Act, 1908, and the State Forests Act, 1908, and regulations thereunder, that written tenders will be received at the District Lands Office, Auckland, from the proprietors of existing sawmills and logging contractors, up till 12 o'clock noon on Monday, 27th November, 1911, for the purchase of the kauri and other milling-timbers standing on the undermentioned lots.

SCHEDULE.

AUCKLAND LAND DISTRICT.—HOBSON COUNTY.

Lot 1.

*Part Block XIV, Mangakahia Survey District.—Section 3, Pekapekarau State Forest.*

2,062 GREEN and dry kauri-trees, containing approximately 5,487,101 sup. ft. (standing measurement).

3,681 rimu-trees, containing approximately 2,576,570 sup. ft. (standing measurement).

864 totara-trees, containing approximately 972,864 sup. ft. (standing measurement).

3,989 kahikatea-trees, containing approximately 6,447,292 sup. ft. (standing measurement).

463 matai-trees, containing approximately 416,211 sup. ft. (standing measurement).

Distinguishing brands, thus : III and X<sup>F</sup>Λ.

Time for removal : Six years.

Upset prices : Kauri 2s. 6d., rimu 7d., totara 1s. 6d., kahikatea 7d., and matai 1s. per 100 sup. ft.

Terms : One-fifth in cash within fourteen days after acceptance of tender, one-fifth in nine months, one-fifth in eighteen months, one-fifth in twenty-seven months, and one-fifth in thirty-six months thereafter.

Defective and undersized trees not included in this sale.

Lot 2.

*Part Blocks XIII and XIV, Mangakahia Survey District.—Section 4, Pekapekarau State Forest.*

2,137 green and dry kauri-trees, containing approximately 4,946,921 sup. ft. (standing measurement).

4,292 rimu-trees, containing approximately 3,120,136 sup. ft. (standing measurement).

656 totara-trees, containing approximately 544,806 sup. ft. (standing measurement).

3,842 kahikatea-trees, containing approximately 5,584,829 sup. ft. (standing measurement).

319 matai-trees, containing approximately 182,625 sup. ft. (standing measurement).

Distinguishing brand, thus : A.

Time for removal : Six years.

Upset prices : Kauri 2s. 6d., rimu 7d., totara 1s. 6d., kahikatea 7d., and matai 1s. per 100 sup. ft.

Terms : One-fifth in cash within fourteen days after acceptance of tender, one-fifth in nine months, one-fifth in eighteen months, one-fifth in twenty-seven months, and one-fifth in thirty-six months thereafter.

Defective and undersized trees not included in this sale.

Lot 3.

*Part State Forest Reserve, Block XIII, Mangakahia Survey District.*

12 green kauri-rickers, containing approximately 4,893 sup. ft. (standing measurement).

361 green and scorched rimu-trees, containing approximately 242,572 sup. ft. (standing measurement).

327 green and scorched kahikatea-trees, containing approximately 463,624 sup. ft. (standing measurement).

Distinguishing brand, thus : A.

Time for removal : One year.

Upset prices : Kauri 1s., rimu and kahikatea 6d. per 100 sup. ft.

Terms : Half in cash within fourteen days after acceptance of tender, and half in six months thereafter.

49 totara-trees, branded FR, not included in this sale.

Lot 4.

*Crown Land, Part Block IV, Kaihu Survey District.*

8 kauri-trees, containing approximately 6,332 sup. ft. (standing measurement).

723 rimu-trees, containing approximately 525,987 sup. ft. (standing measurement).

374 totara-trees, containing approximately 345,391 sup. ft. (standing measurement).

2,898 kahikatea-trees, containing approximately 3,743,656 sup. ft. (standing measurement).

Distinguishing brands, thus : I : II and V<sup>Λ</sup>.

Time for removal : Three years.

Upset prices : Kauri and totara 1s., rimu and kahikatea 7d. per 100 sup. ft.

Terms : One-fifth in cash within fourteen days after acceptance of tender, one-fifth in seven months, one-fifth in fourteen months, one-fifth in twenty-one months, and one-fifth in twenty-eight months thereafter.

19 rimu-trees and 97 kahikatea-trees (defective), branded FR, not included in this sale; also 169 matai-trees, branded FR, reserved for settlement purposes.

Lot 5.

*Crown Land, Part Block XVI, Tutamoe Survey District, and Block IV, Kaihu Survey District.—Tangawahine Watershed.*

200 green and dry kauri-trees, containing approximately 478,731 sup. ft. (standing measurement).

Distinguishing brand, thus : V.

Time for removal : One year.

Upset price : 2s. per 100 sup. ft.

Terms : Cash within fourteen days after acceptance of tender.

20 faulty and undersized trees, branded FR, not included in this sale.

CONDITIONS.

1. Intending tenderers are expected to visit the locality and to satisfy themselves in every particular on all matters relating to their tender.

2. The aforementioned quantities, qualities, and kind as to the said timber shall be taken as sufficiently accurate for the purpose of this sale, and no contract for purchase shall be voidable, nor shall the successful tenderer be entitled to any abatement in price, by reason of the said timber being of less quantity, quality, and kind than as stated herein or in any advertisement having reference to the said timber, nor shall any extra sum be claimed by the Crown if for any reason the quantity of timber is found to be in excess of that stated herein.

3. No tender will be considered wherein a less royalty is offered than the upset prices as stated in terms of each lot.

4. All timber on each lot, whether standing, felled, or in logs, shall remain the property of the Crown until all the instalments are paid.

5. Offers from the successful tenders will be considered for the purchase of the undersized and defective timber mentioned herein.

6. In all lots the quantities stated are standing measurements, and only those trees bearing the special distinguishing brand shown in each lot are included in this sale.

7. Should any dispute arise as to boundaries, the decision of the Commissioner of Crown Lands shall be final.

8. In the event of any of the above lots not being disposed of, applications may be received and dealt with at any time within six months from the above date of closing of tenders (unless previously formally withdrawn), providing, however, that the amount offered is not less than the upset prices stated herein.

9. No extension of time for removal of timber will be allowed successful tenderers who bleed, or permit bleeding of, kauri-trees included in this sale, unless full payment of purchase-money is first made.

10. All tenders must be submitted on forms which will be supplied on application to the above office, and envelopes enclosing same to be marked "Tender for Timber," and addressed to the Commissioner of Crown Lands, Auckland.

11. In lots where terms of payment may have been arranged, any breach of the foregoing conditions of sale will render the "on demand" promissory notes liable to be presented for immediate payment.

12. The highest or any tender not necessarily accepted.

TERMS.

Separate tenders for the various lots of timber must be accompanied by a deposit of 5 per cent. on the amount of tender, in cash, marked cheque, or post-office order; the balance to be paid, if tender accepted, as specified in the terms of each lot, together with the timber-cutting license fee of £1 ls.

All such instalment payments shall bear interest at the rate of 5 per cent. per annum as from the date of acceptance of tender, and, with the interest added, shall be secured by "on demand" promissory notes made and indorsed to the satisfaction of the Commissioner of Crown Lands.

ERIC C. GOLD SMITH,  
Commissioner of Crown Lands.

## NATIVE LAND COURT NOTICES.

*Sitting of the Native Land Court at Auckland.*

Registrar's Office, Auckland, 13th November, 1911.

NOTICE is hereby given that the Chief Judge of the Native Land Court will hold a sitting at Auckland on the 4th day of December, 1911, to inquire into the several matters mentioned in the Schedule hereunder written, in respect of which applications have been received by the Registrar, and all such other matters as may be lawfully brought before it.

[Auckland, 1911-57.]

E. P. EARLE, Registrar.

## SCHEDULE.

## APPLICATIONS UNDER SECTION 50 OF THE NATIVE LAND ACT, 1909.

No.	Name of Applicant.	Name of Land.	Decision in respect of which Application is made.
1	Taipari Mere Maeau and Huapiri (Parr and Blomfield)	Te Akau B No. 15B and B No. 16	Judgment of the Native Land Court, dated 4th August, 1910, appointing a successor to Karaka te Au, deceased.
2	Maraea Kamira .. ..	Awaroa Nos. 1A and 2B ..	Judgment of the Native Land Court, dated 9th April, 1908, appointing successors to Rewi Paparangi, deceased.
3	Waata Hohepa and others ..	Te Karae .. ..	Judgment of the Tokerau Maori Council, dated 15th November, 1905, on investigation of title.
4	Tua Hotene and others ..	Kiwitahi No. 3A ..	Judgment of the Native Land Court, dated 7th November, 1868, on investigation of title.
5	Ngawai Rupene .. ..	Mataitai No. 1A ..	Judgment of the Native Land Court, dated 20th February, 1911, appointing successors for Mere Horohinu.
6	Wiremu Hohaia .. ..	Matauri No. 1 ..	Judgment of the Native Land Court, dated 19th September, 1910, on investigation of title.
7	Anaha Kingi and others ..	„ No. 2 ..	Judgment of the Tokerau Maori Council on investigation of title.
8	Paremoari Haimona Rewa ..	Moerangi .. ..	Judgment of the Native Land Court, dated 7th May, 1910, on investigation of title.
9	Wiriwiri Pikia and others ..	„ .. ..	Judgment of the Native Land Court, dated 3rd June, 1911, partitioning the land.
10	Remana Kiwikiwi .. ..	Motatau No. 5 ..	Judgment of the Appellate Court, dated 17th September, 1910, on investigation of title.
11	Otene Paora and others ..	Orakei Native Reserve ..	The judgment on investigation of title.
12	Hemi Taurua .. ..	Oromahoe .. ..	Judgment of the Tokerau Maori Council, dated 13th August, 1906, on investigation of title.
13	Wiri Henare Toka and others ..	Otamatea and Hanerau ..	Judgment of the Tokerau Maori Council, dated 23rd June, 1905, on investigation of title.
14	Rena Wharewaka and others ..	Paihia Nos. 1 and 3 ..	Judgment of the Native Land Court, dated 20th October, 1897, on investigation of title.
15	Raiha Hone and others (Parr and Blomfield) ..	Parish of Pepepe, Lot 81 ..	Judgment of the Native Land Court, dated 31st May, 1910, appointing successors to Piri Takotokino, deceased.
16	Kuratau te Aku and others (T. A. Moresby)	Pouarua Pipiroa Nos. 3B, 2A, 2B, and 2C	Judgment of the Native Land Court, dated 19th December, 1910, cancelling partition orders.
17	Poutana Maihi and others (Earl and Kent)	Te Puna, Lot 154 ..	Judgment of the Appellate Court, dated 7th November, 1910, under subsection (3) of section 50 of the Native Land Act, 1909.
18	Rihi Kahurereawai .. ..	Te Raetepapa North A ..	Judgment of the Native Land Court, dated 14th December, 1910, partitioning the land.
19	Hone Hamiora Hau .. ..	Rangaunu Nos. 6 and 13 ..	Judgment of the Native Land Court, dated 6th December, 1894, partitioning the land.
20	Toheriri Tawhana and others ..	Rangitoto-Tuhua No. 64F	Judgment of the Native Land Court, dated 21st February, 1901, on investigation of title.
21	Poihaere Tuhoro .. ..	No. 66B ..	Judgment of the Native Land Court appointing successors to Rangiterewai Nuitone.
22	Wi Poutu .. ..	Ruapekapeka 6B No. 2 ..	Judgment of the Native Land Court, dated 8th November, 1910, partitioning the land.
23	Te Awarutu te Awaitaia ..	Takapaunui and Ohiapoko	Judgment of the Native Land Court, dated 16th June, 1908, on investigation of title.
24	Tupakihi Kaniira .. ..	Wairoa .. ..	Judgment of the Tokerau Maori Council, dated 23rd June, 1905, on investigation of title.
25	Makere Hoete .. ..	Waitakaruru No. 2 ..	Judgment of the Native Land Court, dated 29th April and 27th July, 1898, on investigation of title.
26	Rena Wharewaka and others ..	Whakarapa .. ..	Judgment of the Appellate Court affirming order of the Native Land Court on investigation of title.
27	Here Kotukutuku and another	Whangape, Lot 32B ..	Judgment of the Native Land Court, dated 25th July, 1910, appointing successors to Ihaka Taitau, deceased.
28	Hore Paerimu .. ..	Orakei .. ..	Judgment of the Native Land Court partitioning the land.
29	Hohua Taimona and others ..	Kokohuia B .. ..	Judgment of the Native Land Court, dated 14th April, 1904, appointing successors to Taimona Pita.
30	Te Reweti Paengahuru and others	Purupuru .. ..	Decision of the Native Land Court, given 23rd August, 1901, on investigation of title.
31	Atareria Tikitiki and others ..	Hanerau .. ..	Decision of the Tokerau Maori Council, given 23rd June, 1905, determining owners.
32	Tamati Tangihia and others ..	Ruawahia .. ..	Decision of the Native Land Court, given 13th June, 1899, appointing successors to Meretaka Tangihia, deceased.
33	Maera Kuao and another ..	Motatau No. 5 ..	Decision of the Native Land Court on partition.
34	Hori Wharerarauhe .. ..	Lot 2, Parish of Opuatia ..	Decision of the Native Land Court, given the 30th November, 1892, appointing successors to Eraihia Makomako, deceased.

## Sitting of the Native Land Court at Te Kuiti.

Registrar's Office, Auckland, 11th November, 1911.

NOTICE is hereby given that the several matters mentioned in the Schedule hereunder written will be heard by the Native Land Court sitting at Te Kuiti on the 24th day of November, 1911, or as soon thereafter as the business of the Court will allow.

[Auckland, 1911-58.]

E. P. EARLE, Registrar.

SCHEDULE.  
APPLICATIONS FOR PARTITION.

No.	Name of Applicant.	Name of Land.
700	Kuratu te Aku (T. A. Moresby)	Aorangi B.
701	Hone Pohe Hemoata	Hauturu West No. 2B.
702	Hana Amohia	Kakepuku 9B No. 3.
703	Hemera te Uru and another (A. H. Howarth)	Karuotewhenua 1c No. 4.
704	Te Tata Henare	" B 5c No. 5.
705	Te Araroa Huiao and another (Earl, Kent, and Howarth)	Kinohaku East No. 2, Section 1.
706	Tokoroa Poihipi (Earl, Kent, and Howarth)	" No. 3D, Section 3.
707	Tira Hinewai (Earl, Kent, and Howarth)	Kinohaku West K, Section 1.
708	Ereni Ngatai	Kuiti 2B No. 3.
709	Rawiri Heneri (Earl, Kent, and Howarth)	Marokopa No. 5B.
710	Te Hinurewa Turaki	Ohura South F 2B No. 2.
711	Makere te Uruweherua (Earl, Kent, and Howarth)	" G No. 4L, Section 1.
712	Te Waka Waiora	" K No. 2B.
713	Turaki Maikuku	" K No. 2, Section 2B No. 1.
714	Te Wherowhero Tawhiao	Orahiri No. 3B.
715	Te Huia Kingi (Earl, Kent, and Howarth)	Otorohanga 1F No. 1.
716	Te Huia Kingi	" 1F, Section 4D.
717	Tamihana te Huirau (Earl, Kent, and Howarth)	Piha No. 1A.
718	Tira Hinewai and others (Earl, Kent, and Howarth)	" 1B No. 3.
719	Te Maanu Mahuki (Endean and Holloway)	Pukeroa-Hangatiki No. 2c, Section 4A.
720	Pouhau Matuira (Endean and Holloway)	" 2c No. 4B.
721	Koroheke Parinui and others	" 4c No. 2.
722	Tukahui Aperahama	Puketarata 19L No. 2.
723	Tutahanga te Wano (Earl, Kent, and Howarth)	Rangitoto-Tuhua No. 52c, Section 2.
724	Waeroa Matena (Earl, Kent, and Howarth)	" No. 60A, Section 3B.
725	Arapata te Rangituataka (Earl, Kent, and Howarth)	" No. 61F, Section 3.
726	Poihaere Tuhoro (Earl, Kent, and Howarth)	" No. 64s.
727	Hohepa Petera	" No. 77B, Section 1.
728	Tomika Kereti (Endean and Holloway)	" 77D No. 3B.
729	Kaharoa Tawhana (Earl, Kent, and Howarth)	" No. 80B, Section 4.
730	Tangihare Tawhana (Earl, Kent, and Howarth)	Umukaimata 1A No. 2B.

## APPLICATIONS FOR SURVEY CHARGING ORDERS.

No.	Name of Applicant.	Name of Land.	Amount due.
731	Chief Surveyor, Auckland	Kinohaku East Nos. 3D, 8A, and 3	£ s. d. 6 16 1
732	" "	" Nos. 3D, 8A, and 6	31 5 0
733	Percy Ward	Maraeroa C	247 11 6
734	Chief Surveyor, Auckland	Orahiri No. 2, Section 6B No. 1	2 12 11
735	" "	Otorohanga 1F No. 5B	3 0 7
736	" "	" 1F No. 5C	8 10 11
737	" "	" 1F No. 5D	3 11 11
738	" "	" 1F No. 5E	8 5 3
739	" "	" 1F No. 5F	7 5 8
740	" "	" 1F No. 5G	27 12 1
741	" "	" 1F No. 3B	2 16 7
742	" "	Ouruwhere 3G No. 1	1 1 10
743	" "	" 3G No. 2	1 1 10
744	" "	" 3G No. 3	1 1 10
745	" "	" 3G No. 4	1 1 10
746	" "	" 3G No. 5	1 1 10
747	" "	" 3G No. 6	1 1 10
748	" "	" 3G No. 7	1 2 0
749	" "	" 3G No. 8	1 1 10
750	" "	" 3G No. 9	1 1 10
751	" "	" 3G No. 10	1 2 0
752	" "	" 3G No. 11	1 1 10
753	" "	" 3G No. 12	1 1 10
754	" "	" 3G No. 13	1 1 10
755	" "	" 3G No. 14	1 1 10
756	" "	" 3G No. 15	1 2 0
757	" "	" 3G No. 16	1 1 10
758	" "	" 3G No. 17	1 1 10
759	" "	" 3G No. 18	1 1 10
760	" "	" 3G No. 19	1 2 0
761	" "	" 3G No. 20	1 2 0
762	" "	" 3G No. 21	1 2 0
763	" "	" 3G No. 22	1 2 0
764	" "	Pukenui 2F No. 3	24 5 5
765	" "	Pukeroa-Hangatiki 2B No. 1	6 8 2
766	" "	" 2B No. 2	15 9 9
767	" "	" 4c No. 2A	18 0 0
768	" "	Rangitoto-Tuhua 52F Nos. 1, 2, and 3	219 11 6

## MATTER REFERRED BACK BY THE NATIVE APPELLATE COURT TO THE NATIVE LAND COURT FOR ADJUDICATION.

No.	Name of Land.	Nature of Reference.
769	Kinohaku West E, Section 1, Nos. 1D, E, and F	The partition of the land.

## APPLICATIONS TO ASSESS THE AMOUNT OF COMPENSATION PAYABLE TO NATIVE OWNERS FOR LAND TAKEN UNDER THE PUBLIC WORKS ACT, 1908.

No.	Name of Applicant.	Name of Land.	Area taken.	Purpose for which taken.
770	H. Hine, Borough Solicitor, Te Kuiti	Te Kuiti Township, Lots 8 and 19, Block VI	A. R. P. .. ..	Borough buildings site.
771	Ditto .. .. .	Te Kuiti 2B No. 10	.. ..	A quarry.
772	" .. .. .	Pukenui 2D No. 3g	.. ..	A public pound.

## APPLICATIONS UNDER SECTION 182 OF THE NATIVE LAND ACT, 1909.

No.	Name of Applicant.	Name of Land.	Nature of Application.
773	Hariwhenua Herangi and others (trustees for the minors in the block)	Kakepuku No. 1B	For leave to borrow from the New Zealand State-guaranteed Advances Office the sum of one hundred and twenty-three pounds (£123) for the purposes of the trust.
774	Ditto .. .. .	" No. 2C, Section 11	For leave to borrow from the New Zealand State-guaranteed Advances Office the sum of two hundred and thirty one pounds (£231) for the purposes of the trust.

## APPLICATIONS FOR EXCHANGE.

No.	Name of Applicant.	Name of Land proposed to be exchanged.
775	(Te Manu Hakopa .. .. . Waimatuna Moerua (Endean and Holloway)	Te Kumi No. 7D, Section 2. Rangitoto A12B and Turoto D2, Section 2B.
776	Ditto .. .. .	Ditto.

*Sitting of the Native Land Court at Shortland, Thames.*

Registrar's Office, Auckland, 6th November, 1911.

NOTICE is hereby given that a sitting of the Native Land Court will be held at Shortland, Thames, on the 4th day of December, 1911, to hear and determine the several matters mentioned in the Schedule hereunder written, in respect of which applications have been received by the Registrar, and all such other matters as may be lawfully brought before it.

[Auckland, 1911-56.]

E. P. EARLE, Registrar.

## SCHEDULE.

## APPLICATIONS FOR PARTITION.

No.	Name of Applicant.	Name of Land.
42	Karurua Ngakaho .. .. .	Aorangi A.
43	Mereana Iheihe .. .. .	" D.
44	Taumaha Aperaha .. .. .	" No. 4.
45	Hohepa Tauhou and others (Earl and Kent)	Aroha, Block V, Section 5A No. 1.
46	Hutana Karapuha .. .. .	" Block IX, Section 30.
47	" .. .. .	" Block IX, Section 31.
48	Paora Tuinga and Tana Whanau	Awaiti No. 1A.
49	Paora Tuinga .. .. .	" 1B No. 2.
50	Tiriora Tiora .. .. .	" 1H No. 2A.
51	Waana Matene .. .. .	Hautekamakama.
52	T. A. Moresby (solicitor for Hoani Pahau)	Hikutaia 1A No. 2.
53	Parepumi te Whetuiti .. .. .	Hoetainui No. 6A.
54	Haimona Hikahaere .. .. .	" No. 6B.
55	Pohutuhutu and others .. .. .	" North 6B No. 2.
56	Parepumi te Whetuiti .. .. .	" North 6B No. 2.
57	Kahukoti te Amo .. .. .	" South No. 1B.
58	Haroira Taupo .. .. .	Horahia Opou.
59	Paora Tuinga .. .. .	" No. 4B.
60	Ngawiki Potae .. .. .	Kaikahu No. 1.
61	Pani Paura Pereniki (Porritt and Mueller)	Komata South 1c No. 2.
62	Rata Hohepa .. .. .	Mako B, Section 2.
63	" (Edwin Clendon) .. .. .	" B, Section 2B.

APPLICATIONS FOR PARTITION—continued.

No.	Name of Applicant.	Name of Land.
64	Tawhi Maketu and others .. .. .	Manaiā 1B No. 2B.
65	Herewini Tamaiwhiua and Ngahuia Hohepa .. .. .	Marutuahu.
66	Arepata Tineia and others .. .. .	Moehau 1K.
67	" .. .. .	" 3A.
68	Poata Makuini and Wahu Peke .. .. .	" 3D No. 3.
69	Mereaina Iheihe .. .. .	Ngatitamatera Reserve B.
70	Tira Horomona .. .. .	Pakirarahi No. 2.
71	" .. .. .	" No. 1.
72	Miriama Kipa .. .. .	Parehuia No. 2c.
73	Te Rare Pukeroa (Edwin Clendon) .. .. .	Patate.
74	Wiremu Taurua .. .. .	Papaaroha No. 5A, Section 2.
75	Tamawhiua Rawiri, Hekori Amomai, and others .. .. .	Peka o Hawaiki.
76	Ngawiki Potae .. .. .	Puketeawainui No. 1.
77	Paora Tuinga and others .. .. .	Pururuwai No. 3.
78	Waru Mita te Puku and Eparaima Poori .. .. .	Rawhitiroa.
79	Rawiri te Ua (Edwin Clendon) .. .. .	Tarakewhatai No. 2B.
80	Hakere Paraone .. .. .	Taurarahi.
81	Paora Tuinga and others .. .. .	Tiritiri No. 2B.
82	Hori More and Mare Teretiu .. .. .	Totara.
83	Ngawiki Potae, alias Ngawiki te Pora, and others .. .. .	Uriwha Reserve A.
84	Arepata Tineia and others .. .. .	Waikanae No. 4.
85	Kerei Piahana and Matehaere Honana .. .. .	" No. 4.
86	Merea Wikiriwhi and Tame Matehaere .. .. .	Wairau No. 2.
87	Herewini Tamaiwhiua and Ngahuia Hohepa .. .. .	Waitotara.
88	Tamaiwhiua Rawiri and others .. .. .	Whangamata No. 4.

APPLICATIONS FOR EXCHANGE.

No	Name of Applicant.	Name of Land proposed to be exchanged.
89	(Tukukino Hunia .. .. . (Rangi Kiniwe .. .. .	Puru Reserve, Section 4B No. 2. Komata South 1A No. 2.

APPLICATION FOR PROBATE.

No.	Name of Applicant.	Name of Deceased.
90	Paretaiko te Ipumanga .. .. .	Ripeka te Pea.

APPLICATIONS TO ASSESS THE AMOUNT OF COMPENSATION PAYABLE TO OWNERS OF NATIVE LAND TAKEN BY PROCLAMATION UNDER THE PUBLIC WORKS ACT, 1908.

No.	Name of Applicant.	Name of Land.	Area taken.	Purpose for which taken.
91	The Minister of Public Works .. .. .	Kopuarahi No. 1B .. .. . " 3D No. 2 .. .. . " 3C No. 2 .. .. . Horahia Apou No. 5B .. .. . " No. 3B .. .. . Kopururuwai No. 1B .. .. . " No. 4B .. .. . Tiritiri 4B No. 2 .. .. . Makumaku No. 2 .. .. .	A. R. P. 484 0 10 101 0 18 69 0 10 53 0 37 19 3 2 95 0 21 38 3 22 31 1 31 125 0 0	For the more effective carrying-out of drainage and other works. Hauraki Plains (Piako).

APPLICATIONS FOR SURVEY CHARGING ORDERS.

No.	Name of Applicant.	Name of Land.	Amount due.
92	The Chief Surveyor, Auckland .. .. .	Te Aroha, Block V, Section 5A No. 3 .. .. .	£ s. d. 26 8 1
93	" .. .. .	" IX, Lot 2A, Section 28 .. .. .	3 3 3
94	" .. .. .	" XI, Lot 1 of southern portion of Section 5 .. .. .	8 16 3
95	" .. .. .	" XI, Lot 2 of southern portion of Section 5 .. .. .	6 17 8
96	" .. .. .	" XI, Lot 3 of southern portion of Sections 6 and 7c .. .. .	20 0 2
97	" .. .. .	Herekahi-o-Kumara .. .. .	33 19 8
98	" .. .. .	Motu Oruhe .. .. .	10 10 0
99	" .. .. .	Papaaroha 5D Nos. 1 and 2 .. .. .	8 7 0
100	" .. .. .	Pukemaukuku .. .. .	16 4 4
101	" .. .. .	Pututu .. .. .	16 16 10

*Sitting of the Native Land Court at Wanganui.*

Registrar's Office, Wanganui, 8th November, 1911.

NOTICE is hereby given that the Chief Judge of the Native Land Court will hold a sitting at Wanganui on the 23rd day of November, 1911, to inquire into the several matters mentioned in the Schedule hereunder written, in respect of which applications have been received by the Registrar, and all such other matters as may be lawfully brought before it.

(Wanganui, 1911-21.)

A. H. MACKAY, Registrar.

## SCHEDULE.

## APPLICATIONS UNDER SUBSECTION (1) OF SECTION 50 OF THE NATIVE LAND ACT, 1909.

No.	Name of Applicant.	Name of Land.	Decision in respect of which Application is made.
1	Merita Ngarori .. ..	Taurewa No. 4 West ..	Application under section 50/09, for leave to appeal from decision on the determination of the relative interests.
2	Rangipahoka Pakau .. ..		Ditto.
3	Inia Ranginui .. ..	Taurewa East .. ..	"
4	Henare Tumango .. ..	Kahakaha No. 1 .. ..	Application under section 50/09 for leave to appeal from decision given on partition and definition of relative interests.
5	Turaki Maikuku .. ..	Koiro No. 5 .. ..	Application under section 50/09 for leave to appeal from decision given on succession to interests of Wereta Whiutahi, deceased.
6	Wiripo Tohiraukura .. ..	Taurewa No. 4 East; Taurewa No. 4 West	Application under section 50/09 for leave to appeal from decision given on the definition of the relative interests, for inclusion of other names.
7	Perata Maikuku .. ..	Waimarino No. 3 .. ..	Application under section 50/09 for leave to appeal from decision given on succession to Waitaruna te Opetini, deceased.
8	Te Aonui Poumua .. ..	Section 95, Block I, Op- nake, Orimupiko, Nga- titu, and other lands	Application under section 50/09 for leave to appeal from decisions on succession to Matiu Wharematangi, deceased.
9	Harata Tuhakararo .. ..	Orimupiko .. ..	Ditto.
10	Taehuri Katerina .. ..	Oeo, Block I, Section 66, and Orimupiko	Application under section 50/09 for leave to appeal from decision on succession to Hakaraia Tangaika, deceased.
11	Wi Pukere .. ..	Section 12, Block I, Upper Waitara	Decision of the Native Land Court, given 2nd June, 1909, appointing successors to the interest of Harawira Mokena, deceased.

## APPLICATION UNDER SUBSECTION (3) OF SECTION 50 OF THE NATIVE LAND ACT, 1909.

No.	Name of Applicant.	Name of Land.	Decision in respect of which Application is made.
12	Wi Pukere .. ..	Upper Waitara, Section 10, Block I, and other lands	Decision of the Native Appellate Court, given on the 24th December, 1908, appointing successors to the interests of Harawira Mokena, deceased.

*Sitting of the Native Land Court at Masterton.*

Registrar's Office, Wellington, 15th November, 1911.

NOTICE is hereby given that a sitting of the Native Land Court will be held at Masterton on the 1st day of December, 1911, to hear and determine the several matters mentioned in the Schedule hereunder written.

(Wellington, 1911-56.)

E. A. WELCH, Registrar.

## SCHEDULE.

## REFERENCE BY THE CHIEF JUDGE TO THE NATIVE LAND COURT FOR INQUIRY AND REPORT.

No.	Name of Land.	Nature of Inquiry.
1	Paehuia and Oruatamere Blocks .. ..	To inquire as to correctness or otherwise of the plan and survey of the subdivisions of the blocks, and to ascertain if there are any objections to the said plan and survey.

*The Native Land Court Act, 1894.*IN THE NATIVE LAND COURT OF NEW ZEALAND,  
GISBORNE DISTRICT.

In the matter of section 34 of the Maori Land Claims Adjustment and Laws Amendment Act, 1907, and of the Native Land Court Act, 1894; and in the matter of the block of land known as Te Kopuni.

WHEREAS, pursuant to section 34 aforesaid, the Chief Judge of this honourable Court referred to the Native Land Court for inquiry and report the issue as to "whether or not Karauria Pahura or Arapera Pahura intended at any time to admit other persons as owners in the above-mentioned block";

And whereas, after due inquiry, the said Court, on the 16th day of June, 1910, reported that neither Karauria Pahura nor Arapera Pahura ever intended to admit others in the title, and that there was no evidence of fraud:

And whereas the said report was appealed against, and the Native Appellate Court, after due hearing, dismissed the appeals and upheld the said report:

Now, therefore, I, Jackson Palmer, the Chief Judge of the Native Land Court, do hereby order that no amendment of the Crown grant or title to the said land is necessary.

As witness my hand, this 20th day of October, 1911.

JACKSON PALMER,  
Chief Judge.



## MAORI LAND ADMINISTRATION NOTICES.

*Meeting of the Ikaroa District Maori Land Board.*

Wellington, 14th November, 1911.

NOTICE is hereby given that the several matters mentioned in the Schedule hereunder written will be considered at a meeting of the Ikaroa District Maori Land Board to be held at Wellington on Tuesday, the 28th day of November, 1911, at 10.30 o'clock a.m., or as soon thereafter as the business of the Board will allow. At the conclusion of local business the Board will adjourn to Masterton.

J. B. JACK, President.

## SCHEDULE.

## APPLICATIONS FOR CONFIRMATION OF ALIENATIONS.

No.	Record No.	Nature of Alienation.	Date.	Name of Land.	Names of Parties.
1	I. 1911/571	Transfer ..	23 September, 1911 ..	Taonui - Ahuaturanga No. 2B, Subdivision 8 ..	Tura Mereti to Herbert Smith (Chapman, Skerrett, Wylie, and Tripp).
2	I. 1911/573	Lease ..	2 October, 1911 ..	Parangarahu No. 7 ..	Karena Kotuku and others to John Harold Morrison (McGrath and Willis).
3	I. 1911/574	Transfer ..	2 ,, 1911 ..	..	Karena Kotuku and others to John Harold Morrison (McGrath and Willis).
4	I. 1911/575	Lease ..	30 September, 1911 ..	Parangarahu No. 3 ..	Matiria Hohua and others to William Thomas James Morrison (McGrath and Willis).
5	I. 1911/576	Transfer ..	30 ,, 1911 ..	..	Ditto.
6	I. 1911/580	..	..	Uruokakite North No. 2B	Takana Kingi and another to Alice Burch (A. J. Bathgate).
7	I. 1911/581	Lease ..	9 October, 1911 ..	Takapuahia A No. 2 ..	Matiu Teieti and others to Ringi Horomona (H. T. McOtonare).
8	I. 1911/582	Conveyance ..	14 ,, 1911 ..	Carnarvon, Section 385 (part)	Karauria te Tihi to Richard Joseph Harper (John Graham).
9	I. 1911/584	Transfer ..	21 ,, 1911 ..	Mangawhero No. 1 ..	Rewanui te Mokena to Edward Philip Levien (Bell, Gully, Bell, and Myers).
10	I. 1911/585	..	21 ,, 1911 ..	.. No. 3A ..	Emiri Paki to Edward Philip Levien (Bell, Gully, Bell, and Myers).
11	I. 1911/586	..	12 ,, 1911 ..	Otaki, Sections 177, 178, 179, 186, and 187 (part)	Ngawehenga Keremihana and another to Hamiona Ranapiri (Bell, Gully, Bell, and Myers).
12	I. 1911/587	..	4 August, 1911 ..	Ngapuketurua No. 5B ..	Taiawhio te Tau to Ani Waaka (Robinson and Hand-Newton).
13	I. 1911/588	..	..	Waikopiro 1B, Section 2B No. 2	Tungane Hori and others to Morgan Morgan (Blakiston and Blakiston).
14	I. 1911/589	..	14 October, 1911 ..	Otaki, Section 185 ..	Mirika Hawea and another to Haimona Ranapiri (R. J. Staveley).
15	I. 1911/591	..	19 August, 1911 ..	Paekakariki No. 1D ..	Turama Mohi Nopera and others to Hugh Stewart Pollen (Field and Luckie).
16	I. 1911/592	..	16 September, 1911 ..	Tahitiki Reserve (part) ..	Ani Ratima and others to Arthur William Akers (Loughnan and Jacobs).
17	I. 1911/593	..	13 ,, 1911 ..	Opiki Block (part) ..	Amiria Nepe to Arthur William Akers (Loughnan and Jacobs).
18	I. 1911/594	..	27 October, 1911 ..	Tuwahakatupua 1G No. 2 (part)	Ereni te Aweawe to Arthur William Akers (Loughnan and Jacobs).
19	I. 1911/595	Conveyance ..	3 November, 1911 ..	Carnarvon, Section 356B	Ratima Pekamu and others to Marjorie Fraser (John Graham).
20	I. 1911/596	Transfer ..	17 October, 1911 ..	Makuratawhiti 1B No. 1..	Anihaera Rikihana to Mere Poro-koru (G. H. Harper).
21	I. 1911/597	..	27 ,, 1911 ..	Muhunoa 1B No. 2D (part)	Oriwa te Waru and others to Joseph Henry D'Ath (G. H. Harper).
22	I. 1911/598	Lease ..	23 September, 1911 ..	Ngakaroro 3C, Section 5B	Karepa Kapukai and others to Reginald Michael Burdett D'Ath (G. H. Harper).
23	I. 1911/599	..	4 November, 1911 ..	Muhunoa 3A No. 1E No. 1, Subdivision 12A	Tauhu Roera and another to Puaia Whiley (Bell, Gully, Bell, and Myers).
24	I. 1911/600	Conveyance ..	..	Te Whiti South No. 5 ..	Pane Hemi to Eleanora Louisa Wardell (C. A. Pownall).
25	I. 1911/604	Agreement to lease	4 July, 1911 ..	Te Maipi 7C No. 5 and part 3	Piripi Waaka to Alexander Reside, jun. (A. R. Bunny).
26	I. 1911/605	Lease ..	7 November, 1911 ..	Te Maipi No. 6B ..	Hori te Huki and others to James and Charles Reside (A. R. Bunny).
27	I. 1911/606	Transfer ..	..	Ngarara West A, Section 32D (part)	Ngapera Wi Parata to Nota Whitu Stewart (Moorhouse, Hadfield, and Newman).

APPLICATIONS FOR CONFIRMATION OF ALIENATIONS—*continued.*

No.	Record No.	Nature of Alienation.	Date.	Name of Land.	Names of Parties.
28	I. 1911/607	Transfer ..	14 September, 1911 ..	Tamaki No. 2A, Sub-division 1A	Katipo Eriata to Alice Louisa Hartgill (Fitzherbert and Robertshawe).
29	I. 1911/608	.. ..	10 November, 1911 ..	Pahianui A No. 2A ..	Kipa te Whatanui to Susannah Brown (G. H. Harper).
30	I. 1911/609	.. ..	16 October, 1911 ..	Pahaoa No. 7A (part) ..	Riwai Hemi to Donald William McLaren (R. Ward Tate).
31	I. 1911/610	.. ..	7 ,, 1911 ..	Okoura No. 1 (part) ..	Te One Henare Kingi to Hoani te Whaiti (R. Ward Tate).
32	I. 1911/611	.. ..	14 November, 1911 ..	.. ..	Maota Henare Kingi to Hoani te Whaiti (R. Ward Tate).
33	I. 1911/612	Lease ..	9 ,, 1911 ..	Township of Sandon, part Section 6 of Section 153	Te One Himiona and another to David Whisker (John Graham).
34	I. 1911/613	Transfer ..	8 ,, 1911 ..	Ngawhaka-a-kupe B Block (part)	Horiana Natanahira to Frank Rutherford Bladen (W. G. Beard).
35	I. 1911/614	.. ..	8 ,, 1911 ..	Ditto .. ..	Horiana Natanahira to Henry Featherston Toogood (W. G. Beard).
36	I. 1911/615	.. ..	8 ,, 1911 ..	.. ..	Horiana Natanahira to Alexander James Toogood (W. G. Beard).
37	I. 1911/616	.. ..	31 October, 1911 ..	Ika-a-rua Block ..	Hinewakaemia to George Charles Summerell (W. G. Beard).
38	I. 1911/617	.. ..	9 ,, 1911 ..	Waipuna Block ..	Taiawhio te Tau and others to Thomas Robert Barrer (M. Lavery).
39	I. 1911/618	.. ..	28 August, 1911 ..	Paehuia, Subdivision 2 ..	Hape Renata and others to Thomas Robert Barrer (M. Lavery).
40	I. 1911/619	.. ..	.. ..	Manawatu-Kukutaauaki 4c 5A No. 1D (part)	Rawinia Karehana te Whena and others to Charles Nees (McGrath and Willis).
41	I. 1911/620	.. ..	.. ..	Okoura No. 1 (part) ..	Maata Kingi and others to Ann Sinclair (A. J. Bathgate).
42	I. 1911/621	.. ..	16 October, 1911 ..	Kakotea No. 1D, Section 1	Horomona Wi Parata and others to Herbert John Jillett (Menteath and Ward).
43	I. 1911/622	.. ..	21 September, 1911 ..	Takapuwahia, Subdivision G, Section 1	Rewi Maaka to Herbert John Jillett (Menteath and Ward).
44	I. 1911/623	.. ..	— November, 1911 ..	Aorangi No. 2B ..	Rangimarie to Herbert Gifford Moore and James Bruce Beale (Gifford Moore and Beale).
45	I. 1911/625	.. ..	23 October, 1911 ..	Waikekeno No. 3c ..	Eruha Piripi to Mary Eliza Cameron (Robinson and Hand-Newton).
46	I. 1911/626	.. ..	31 July, 1911 ..	Ngarara West A, Section 78, Lot 38	Hira Parata to the Public Trustee (as administrator of the estate of George Gapes).
47	I. 1911/627	.. ..	.. ..	Papawai No. 5 (part) ..	Rehu Matini to Ramari te Marau (W. H. Manihera).

## APPLICATION FOR PRECEDENT CONSENT TO ALIENATION UNDER SECTION 209 OF THE NATIVE LAND ACT, 1909.

No	Record No.	Nature of Alienation	Name of Land.	Names of Parties.
48	I. 1911/602	Sale .. ..	Pukerua 3c No. 1B .. ..	Winara Parata and others to Elizabeth Laing Gray (Field and Luckie).

## APPLICATIONS IN TERMS OF SECTION 341 OF THE NATIVE LAND ACT, 1909, THAT MEETINGS OF ASSEMBLED OWNERS BE SUMMONED.

No	Record No.	Nature of Proposed Alienation.	Name of Land.	Proposed Resolution for Consideration.
49	I. 1911/583	Sale .. ..	Subsections 1 and 2 of Section 16, Hutt	That the said land be sold to McEwen, Carter, and Co. (Limited) at a price to be not less than the value of the owners' interests in the said land as fixed by the Government valuation (O. and R. Beere).
50	I. 1911/624	Lease .. ..	Akura 3c No. 1A ..	That the said land be leased to Elizabeth Isabella Buick (W. G. Beard).

APPLICATION TO RECOMMEND HIS EXCELLENCY THE GOVERNOR TO CONSENT TO MORTGAGE UNDER SECTION 230 OF THE NATIVE LAND ACT, 1909.

No.	Record No.	Name of Land.	Names of Parties.
51	1911/601	Pukehou 4G No. 12 .. .. .	George Bevan to Arthur Butler France (Sir Kenneth Douglas).

*Notice of Meeting of Owners under Part XVIII of the Native Land Act, 1909.*

REGULATION No. 48.

THE Maori Land Board for the Tokerau Maori Land District hereby notifies that a meeting of the owners of Waima North A No. 5 will be held, in pursuance of Part XVIII of the Native Land Act, 1909, at Kaikohe, on Friday, the 1st day of December, 1911, at 10 o'clock in the forenoon, for the purpose of considering the following proposed resolution:—

“That the said land be sold to R. H. Blennerhasset for the sum of £1 5s. per acre.”

Dated at Auckland, this 13th day of November, 1911.

W. DINNIE,  
President.

*Notice of Meeting of Owners under Part XVIII of the Native Land Act, 1909.*

REGULATION No. 48.

THE Maori Land Board for the Tokerau Maori Land District hereby notifies that a meeting of the owners of Waima North A No. 6A will be held, in pursuance of Part XVIII of the Native Land Act, 1909, at Kaikohe, on Friday, the 1st day of December, 1911, at 10 o'clock in the forenoon, for the purpose of considering the following proposed resolution:—

“That the said land be sold to R. H. Blennerhasset for the sum of £1 5s. per acre.”

Dated at Auckland, this 13th day of November, 1911.

W. DINNIE,  
President.

*Notice of Meeting of Owners under Part XVIII of the Native Land Act, 1909.*

REGULATION No. 48.

THE Maori Land Board for the Tokerau Maori Land District hereby notifies that a meeting of the owners of Waima North A No. 6B will be held, in pursuance of Part XVIII of the Native Land Act, 1909, at Kaikohe, on Friday, the 1st day of December, 1911, at 10 o'clock in the forenoon, for the purpose of considering the following proposed resolution:—

“That the said land be sold to R. H. Blennerhasset for the sum of £1 5s. per acre.”

Dated at Auckland, this 13th day of November, 1911.

W. DINNIE,  
President.

*Notice of Meeting of Owners under Part XVIII of the Native Land Act, 1909.*

REGULATION No. 48.

THE Maori Land Board for the Tokerau Maori Land District hereby notifies that a meeting of the owners of Waima North A No. 13 will be held, in pursuance of Part XVIII of the Native Land Act, 1909, at Kaikohe, on Friday, the 1st day of December, 1911, at 10 o'clock in the forenoon, for the purpose of considering the following proposed resolution:—

“That the timber rights be sold to the Union Box and Packing-case Company (Limited) at a royalty of 6d. per 100 sup. ft. for kahikatea, rimu, and matai. Time for removal, ten years.”

Dated at Auckland, this 13th day of November, 1911.

W. DINNIE,  
President.

*Notice of Meeting of Owners under Part XVIII of the Native Land Act, 1909.*

REGULATION No. 48.

THE Maori Land Board for the Tokerau Maori Land District hereby notifies that a meeting of the owners of Waima North A No. 15 will be held, in pursuance of Part XVIII of the Native Land Act, 1909, at Kaikohe, on Friday, the 1st day of December, 1911, at 10 o'clock in the forenoon, for the purpose of considering the following proposed resolution:—

“That the timber rights be sold to the Union Box and Packing-case Company (Limited) at a royalty of 6d. per 100 sup. ft. for kahikatea, rimu, and matai. Time for removal, ten years.”

Dated at Auckland, this 13th day of November, 1911.

W. DINNIE,  
President.

*Notice of Meeting of Owners under Part XVIII of the Native Land Act, 1909.*

REGULATION No. 48.

THE Maori Land Board for the Tokerau Maori Land District hereby notifies that a meeting of the owners of Waima South A will be held, in pursuance of Part XVIII of the Native Land Act, 1909, at Kaikohe, on Friday, the 1st day of December, 1911, at 2 o'clock in the afternoon, for the purpose of considering the following proposed resolutions:—

“1. That the said land be sold to Annie Nichol森, wife of Oliver Nichol森, of Auckland, for the sum of £1 2s. per acre; or, in the alternative, that the said land be leased to the said applicant for a term of fifty years, at a rental of 5 per centum on the Government valuation for the first twenty-five years, and 5 per centum on the then unimproved value for the remaining twenty-five years, and

a royalty of 6d. per 100 sup. ft. on all timber of a girth of 5 ft. and upwards.

"2. That the said land be sold to George James Crawford for the sum of £1 per acre; or, in the alternative, that the said land be leased to the said applicant for a term of fifty years, at a rental of 1s. per acre per annum for the first twenty-five years, and 5 per centum on the then unimproved value for the balance of the term, and a payment of a royalty of 6d. per 100 sup. ft. on all timber of a girth of 5 ft. and over."

Dated at Auckland, this 13th day of November, 1911.

W. DINNIE,  
President.

*Notice of Meeting of Owners under Part XVIII of the Native Land Act, 1909.*

REGULATION No. 48.

**T**HE Maori Land Board for the Tokerau Maori Land District hereby notifies that a meeting of the owners of Waima South A No. 1 will be held, in pursuance of Part XVIII of the Native Land Act, 1909, at Kaikohe, on Friday, the 1st day of December, 1911, at 2 o'clock in the afternoon, for the purpose of considering the following proposed resolution:—

"That the said land be sold to Edward Henry Davies for the sum of £1 per acre; or, in the alternative, that the said land be leased to the said applicant for a term of fifty years, at a rental of 1s. per acre per annum for the first twenty-five years, and 5 per centum on the then unimproved value for the balance of the term, and a payment of a royalty of 6d. per 100 sup. ft. on all timber of a girth of 5 ft. and over."

Dated at Auckland, this 13th day of November, 1911.

W. DINNIE,  
President.

*Notice of Meeting of Owners under Part XVIII of the Native Land Act, 1909.*

REGULATION No. 48.

**T**HE Maori Land Board for the Tokerau Maori Land District hereby notifies that a meeting of the owners of Waima South A No. 1A will be held, in pursuance of Part XVIII of the Native Land Act, 1909, at Kaikohe, on Friday, the 1st day of December, 1911, at 2 o'clock in the afternoon, for the purpose of considering the following proposed resolution:—

"That the said land be sold to George James Crawford for the sum of £1 per acre; or, in the alternative, that the said land be leased to the said applicant for a term of fifty years, at a rental of 1s. per acre per annum for the first twenty-five years, and 5 per centum on the then unimproved value for the balance of the term, and a payment of a royalty of 6d. per 100 sup. ft. on all timber of a girth of 5 ft. and over."

Dated at Auckland, this 13th day of November, 1911.

W. DINNIE,  
President.

*Notice of Meeting of Owners under Part XVIII of the Native Land Act, 1909.*

REGULATION No. 48.

**T**HE Maori Land Board for the Tokerau Maori Land District hereby notifies that a meeting of the owners of Waima South B will be held, in pursuance of Part XVIII of the Native Land Act, 1909, at Kaikohe, on Friday, the 1st day of December, 1911, at 2 o'clock in the afternoon, for the purpose of considering the following proposed resolutions:—

"1. That the said land be sold to Margaret Lerner, wife of Victor John Lerner, of Auckland, for the sum of £1 2s. per acre; or, in the alternative, that the said land be leased to the said applicant for a term of fifty years, at a rental of 5 per centum on the Government valuation for the first twenty-five years, and 5 per centum on the unimproved value for the remaining twenty-five years, and a royalty of 6d. per 100 sup. ft. on all timber of a girth of 5 ft. and upwards.

"2. That the said land be sold to Edward Henry Davies for the sum of £1 per acre; or, in the alternative, that the said land be leased to the said applicant for a term of fifty years, at a rental of 1s. per acre per annum for the first twenty-five years and 5 per centum on the then unimproved value for the balance of the term, and a payment of a royalty of 6d. per 100 sup. ft. on all timber of a girth of 5 ft. and over."

Dated at Auckland, this 13th day of November, 1911.

W. DINNIE,  
President.

*Notice of Meeting of Owners under Part XVIII of the Native Land Act, 1909.*

REGULATION No. 48.

**T**HE Maori Land Board for the Tokerau Maori Land District hereby notifies that a meeting of the owners of Waima South C will be held, in pursuance of Part XVIII of the Native Land Act, 1909, at Kaikohe, on Friday, the 1st day of December, 1911, at 2 o'clock in the afternoon, for the purpose of considering the following proposed resolution:—

"That the said land be sold to Margaret Lerner, wife of Victor John Lerner, of Auckland, for the sum of £1 2s. per acre; or, in the alternative, that the said land be leased to the said applicant for a term of fifty years, at a rental of 5 per centum on the Government valuation for the first twenty-five years, and 5 per centum on the unimproved value for the remaining twenty-five years, and a royalty of 6d. per 100 sup. ft. on all timber of a girth of 5 ft. and upwards."

Dated at Auckland, this 13th day of November, 1911.

W. DINNIE,  
President.

*Notice of Meeting of Owners under Part XVIII of the Native Land Act, 1909.*

REGULATION No. 48.

**T**HE Maori Land Board for the Tokerau Maori Land District hereby notifies that a meeting of the owners of Waima South C No. 2 will be held, in pursuance of Part XVIII of the Native Land Act, 1909, at Kaikohe, on Friday, the 1st day of December, 1911, at 2 o'clock in the afternoon, for the purpose of considering the following proposed resolution:—

"That the said land be sold to George James Crawford for the sum of £1 per acre; or, in the alternative, that the said land be leased to the said applicant for a term of fifty years, at a rental of 1s. per acre per annum for the first twenty-five years, and 5 per centum on the then unimproved value for the balance of the term, and a payment of a royalty of 6d. per 100 sup. ft. on all timber of a girth of 5 ft. and over."

Dated at Auckland, this 13th day of November, 1911.

W. DINNIE,  
President.

*Notice of Meeting of Owners under Part XVIII of the Native Land Act, 1909.*

REGULATION No. 48.

**T**HE Maori Land Board for the Tokerau Maori Land District hereby notifies that a meeting of the owners of Waima South D will be held, in pursuance of Part XVIII of the Native Land Act, 1909, at Kaikohe, on Friday, the 1st day of December, 1911, at 2 o'clock in the afternoon, for the purpose of considering the following proposed resolutions:—

"1. That the said land be sold to Margaret Lerner, wife of Victor John Lerner, of Auckland, for the sum of £1 2s. per acre; or, in the alternative, that the said land be leased to the said applicant for a term of fifty years, at a rental of 5 per centum on the Government valuation for the first twenty-five years, and 5 per centum on the then unimproved value for the remaining twenty-five years, and a royalty of 6d. per 100 sup. ft. on all timber of a girth of 5 ft. and upwards.

"2. That the said land be sold to John Scott for the sum of £1 per acre; or, in the alternative, that the said land be leased to the said applicant for a term of fifty years, at a rental of 1s. per acre per annum for the first twenty-five years and 5 per centum on the then unimproved value for the balance of the term, and a payment of a royalty of 6d. per 100 sup. ft. on all timber of a girth of 5 ft. and over."

Dated at Auckland, this 13th day of November, 1911.

W. DINNIE,  
President.

*Notice of Meeting of Owners under Part XVIII of the Native Land Act, 1909.*

REGULATION No. 48.

**T**HE Maori Land Board for the Tokerau Maori Land District hereby notifies that a meeting of the owners of Waima South D No. 1 will be held, in pursuance of Part XVIII of the Native Land Act, 1909, at Kaikohe, on Friday, the 1st day of December, 1911, at 2 o'clock in the afternoon, for the purpose of considering the following proposed resolution:—

"That the said land be sold to Margaret Larnar, wife of Victor John Larnar, for the sum of £1 2s. per acre; or, in the alternative, that the said land be leased to the said applicant for a term of fifty years, at a rental of 5 per centum on the Government valuation for the first twenty-five years, and a royalty of 6d. per 100 sup. ft. on all timber of a girth of 5 ft. and upwards."

Dated at Auckland, this 13th day of November, 1911.

W. DINNIE,  
President.

*Notice of Meeting of Owners under Part XVIII of the Native Land Act, 1909.*

REGULATION No. 48.

**T**HE Maori Land Board for the Tokerau Maori Land District hereby notifies that a meeting of the owners of Waima South E will be held, in pursuance of Part XVIII of the Native Land Act, 1909, at Kaikohe, on Friday, the 1st day of December, 1911, at 2 o'clock in the afternoon, for the purpose of considering the following proposed resolution:—

"That the said land be sold to Robert Henry Stewart, of Onehunga, settler, for the sum of £1 2s. per acre; or, in the alternative, that the said land be leased to the said applicant for a term of fifty years, at a rental of 5 per centum on the Government valuation for the first twenty-five years, and 5 per centum on the unimproved value for the remaining twenty-five years, and a royalty of 6d. per 100 sup. ft. on all timber of a girth of 5 ft. and upwards."

Dated at Auckland, this 13th day of November, 1911.

W. DINNIE,  
President.

*Notice of Meeting of Owners under Part XVIII of the Native Land Act, 1909.*

REGULATION No. 48.

**T**HE Maori Land Board for the Tokerau Maori Land District hereby notifies that a meeting of the owners of Waima South F will be held, in pursuance of Part XVIII of the Native Land Act, 1909, at Kaikohe, on Friday, the 1st day of December, 1911, at 2 o'clock in the afternoon, for the purpose of considering the following proposed resolutions:—

"1. That the said land be sold to Robert Henry Stewart, of Onehunga, settler, for the sum of £1 2s. per acre; or, in the alternative, that the said land be leased to the said applicant for a term of fifty years, at a rental of 5 per centum on the Government valuation for the first twenty-five years, and 5 per centum on the unimproved value for the remaining twenty-five years, and a royalty of 6d. per 100 sup. ft. on all timber of a girth of 5 ft. and upwards.

"2. That the said land be sold to Edward Henry Davies for the sum of £1 per acre; or, in the alternative, that the said land be leased to the said applicant for a term of fifty years, at a rental of 1s. per acre per annum for the first twenty-five years, and 5 per centum on the then unimproved value for the balance of the term, and a

payment of a royalty of 6d. per 100 sup. ft. on all timber of a girth of 5 ft. and over."

Dated at Auckland, this 13th day of November, 1911.

W. DINNIE,  
President.

*Notice of Meeting of Owners under Part XVIII of the Native Land Act, 1909.*

REGULATION No. 48.

**T**HE Maori Land Board for the Tokerau Maori Land District hereby notifies that a meeting of the owners of Waima South G will be held, in pursuance of Part XVIII of the Native Land Act, 1909, at Kaikohe, on Friday, the 1st day of December, 1911, at 2 o'clock in the afternoon, for the purpose of considering the following proposed resolutions:—

"1. That the said land be sold to Mary Stewart, wife of R. H. Stewart, of Onehunga, for the sum of £1 2s. per acre; or, in the alternative, that the said land be leased to the said applicant for a term of fifty years, at a rental of 5 per centum on the Government valuation for the first twenty-five years, and 5 per centum on the then unimproved value for the remaining twenty-five years, and a royalty of 6d. per 100 sup. ft. on all timber of a girth of 5 ft. and upwards.

"2. That the said land be sold to William John Hill for the sum of £1 per acre; or, in the alternative, that the said land be leased to the said applicant for a term of fifty years, at a rental of 1s. per acre per annum for the first twenty-five years, and 5 per centum on the then unimproved value for the balance of the term, and a payment of a royalty of 6d. per 100 sup. ft. on all timber of a girth of 5 ft. and over."

Dated at Auckland, this 13th day of November, 1911.

W. DINNIE,  
President.

*Notice of Meeting of Owners under Part XVIII of the Native Land Act, 1909.*

REGULATION No. 48.

**T**HE Maori Land Board for the Tokerau Maori Land District hereby notifies that a meeting of the owners of Whakatere Manawakaia Block will be held, in pursuance of Part XVIII of the Native Land Act, 1909, at Kaikohe, on Friday, the 1st day of December, 1911, at 10 o'clock in the forenoon, for the purpose of considering the following proposed resolution:—

"That the said land be sold to Thomas Forester Buddle, Ivy Emmeline Cooke, and H. Rowley, all of Auckland, for the sum of £1 5s. per acre; or, in the alternative, that the said land be leased to the said applicants for a term of fifty years, at a rental of 1s. 3d. per acre per annum for the first twenty-five years, and 5 per centum on the then unimproved value for the balance of the term."

Dated at Auckland, this 13th day of November, 1911.

W. DINNIE,  
President.

*Notice of Meeting of Owners under Part XVIII of the Native Land Act, 1909.*

REGULATION No. 48.

**T**HE Maori Land Board for the Tokerau Maori Land District hereby notifies that a meeting of the owners of Whawharu No. 1A will be held, in pursuance of Part XVIII of the Native Land Act, 1909, at Kaikohe, on Friday, the 1st day of December, 1911, at 2 o'clock in the afternoon, for the purpose of considering the following proposed resolutions:—

"1. That the said land be sold to Mary Stewart, wife of R. H. Stewart, of Onehunga, for the sum of £1 2s. per acre; or, in the alternative, that the said land be leased to the said applicant for a term of fifty years, at a rental of 5 per centum on the Government valuation for the first twenty-five years, and a royalty of 6d. per 100 sup. ft. on all timber of a girth of 5 ft. and upwards.

"2. That the said land be sold to Thomas Hopa for the sum of £1 per acre."

Dated at Auckland, this 13th day of November, 1911.

W. DINNIE,  
President.

*Notice of Meeting of Owners under Part XVIII of the Native Land Act, 1909.*

## REGULATION No. 48.

**T**HE Maori Land Board for the Aotea Maori Land District hereby notifies that a meeting of the owners of Ohotu 6c Block (341 acres) will be held, in pursuance of Part XVIII of the Native Land Act, 1909, at Wanganui, on Tuesday, the 5th day of December, 1911, at 3 o'clock in the afternoon, for the purpose of considering the following proposed resolution:—

“That the said block of land be sold to Agnes O'Neil, of Palmerston North, for the sum of £515.”

Dated at Wanganui, this 14th day of November, 1911.

J. B. JACK,  
President.

*Notice of Meeting of Owners under Part XVIII of the Native Land Act, 1909.*

## REGULATION No. 48.

**T**HE Maori Land Board for the Aotea Maori Land District hereby notifies that a meeting of the owners of Oruamatua-Kaimanawa will be held, in pursuance of Part XVIII of the Native Land Act, 1909, at Taihape, on Wednesday, the 6th day of December, 1911, at 1.30 o'clock in the afternoon, for the purpose of considering the following proposed resolution:—

“That the said land be vested in the Board, under Part XIV of the Native Land Act, 1909, for the purposes of sale.”

Dated at Wanganui, this 14th day of November, 1911.

J. B. JACK,  
President.

*Notice of Meeting of Owners under Part XVIII of the Native Land Act, 1909.*

## REGULATION No. 48.

**T**HE Maori Land Board for the Aotea Maori Land District hereby notifies that a meeting of the owners of Te Oahurangi Block will be held, in pursuance of Part XVIII of the Native Land Act, 1909, at Wanganui, on Tuesday, the 5th day of December, 1911, at 2.30 o'clock in the afternoon, for the purpose of considering the following proposed resolution:—

“That the said block of land be sold to Agnes O'Neil, of Palmerston North, spinster, at the present Government valuation.”

Dated at Wanganui, this 14th day of November, 1911.

J. B. JACK,  
President.

*Notice of Meeting of Owners under Part XVIII of the Native Land Act, 1909.*

## REGULATION No. 48.

**T**HE Maori Land Board for the Aotea Maori Land District hereby notifies that a meeting of the owners of Parapara 2b2 I Block (78 acres) will be held, in pursuance of Part XVIII of the Native Land Act, 1909, at Wanganui, on Tuesday, the 5th day of December, 1911, at 2 o'clock in the afternoon, for the purpose of considering the following proposed resolution:—

“That the said land be sold to Thomas O'Neil, of Wanganui, for the sum of £258.”

Dated at Wanganui, this 14th day of November, 1911.

J. B. JACK,  
President.

*Notice of Meeting of Owners under Part XVIII of the Native Land Act, 1909.*

## REGULATION No. 48.

**T**HE Maori Land Board for the Aotea Maori Land District hereby notifies that a meeting of the owners of Maraetana 1r will be held, in pursuance of Part XVIII of the Native Land Act, 1909, at Wanganui, on Tuesday, the 12th day of December, 1911, at 11 o'clock in the forenoon, for the purpose of considering the following proposed resolution:—

“That the said land be sold to Nora Josephine Craig for £480.”

Dated at Wanganui, this 14th day of November, 1911.

J. B. JACK,  
President.

*Notice of Meeting of Owners under Part XVIII of the Native Land Act, 1909.*

## REGULATION No. 48.

**T**HE Maori Land Board for the Aotea Maori Land District hereby notifies that a meeting of the owners of Mangaohane No. 1 will be held, in pursuance of Part XVIII of the Native Land Act, 1909, at Wanganui, on Monday, the 4th day of December, 1911, at 2 o'clock in the afternoon, for the purpose of considering the following proposed resolution:—

“That the balance of the block known as Mangaohane No. 1A, containing about 120 acres, be leased to Frederick Geo. Williams, of Mataroa, Farmer, for a term of eleven years, at a yearly rental of 6s. per acre.”

Dated at Wanganui, this 14th day of November, 1911.

J. B. JACK,  
President.

*Notice of Meeting of Owners under Part XVIII of the Native Land Act, 1909.*

## REGULATION No. 48.

**T**HE Maori Land Board for the Aotea Maori Land District hereby notifies that a meeting of the owners of Taumatamahoe 2b2b No. 14 will be held, in pursuance of Part XVIII of the Native Land Act, 1909, at Wanganui, on Monday, the 11th day of December, 1911, at 2 o'clock in the afternoon, for the purpose of considering the following proposed resolution:—

“That the owners of the land known as Taumatamahoe 2b2b No. 14 agree to lease such land to John William Ashwell and James William Clark for a term of forty-two years from the 1st day of October, 1911, at an annual rental for the first twenty-one years of the term for a sum of £125 16s. per annum, and for the second twenty-one years of the term for a sum equivalent to £5 per cent. on the unimproved value of the land at the end of the first period of twenty-one years.”

Dated at Wanganui, this 14th day of November, 1911.

J. B. JACK,  
President.

*Notice of Meeting of Owners under Part XVIII of the Native Land Act, 1909.*

## REGULATION No. 48.

**T**HE Maori Land Board for the Aotea Maori Land District hereby notifies that a meeting of the owners of Maraetana 2b (56 acres) will be held, in pursuance of Part XVIII of the Native Land Act, 1909, at Wanganui, on Tuesday, the 5th day of December, 1911, at 11 o'clock in the forenoon, for the purpose of considering the following proposed resolution:—

“That the above land be sold to Nora Josephine Craig for £42.”

Dated at Wanganui, this 14th day of November, 1911.

J. B. JACK,  
President.

Maori Lands for Sale and Lease by Public Auction.

Office of the Waikato-Maniapoto District  
Maori Land Board,

Auckland, 13th October, 1911.

NOTICE is hereby given, in terms of the Native Land Act, 1909, and the regulations thereunder, that the several lands named in the First and Second Schedules hereto will be offered for sale and lease respectively by public auction, at Otorohanga, at 11.30 o'clock, on Wednesday, 20th December, 1911.  
Term of lease: Twenty-three years, with right of renewal for a further term of twenty-three years.

SCHEDULES.

FIRST SCHEDULE.—LAND FOR SALE.

Lot.	Block.	Survey District.	Area.	Upset Price per Acre.
------	--------	------------------	-------	-----------------------

WAITOMO COUNTY.—AUCKLAND LAND DISTRICT.

*Kinohaku East No. 2, Section 25B No. 2B.*

THIRD-CLASS LAND.

..	I	Otanake	..	A. R. P.	£ s. d.
				156 3 26	1 10 0

Heavy mixed bush, principally tawa and rimu. Three-fourths of section rough and broken. Good soil, on limestone formation; well watered. Access from Te Kumi-Mairoa Road, via Koropupu Road.

*Kinohaku East No. 2, Section 13B No. 2.*

13B	XVI	Kawhia South		197 3 3	1 15 0
-----	-----	--------------	--	---------	--------

About 100 acres good bush, balance tea-tree, scrub, and fern. Undulating land. Fair soil, limestone formation; well watered. Access from Hauturu Road, via Kokakoroa Road, and Mangapohue Road.

*Kinohaku East No. 2, Section 6B No. 2.*

13	XVI	Kawhia South		522 0 0	1 5 0
----	-----	--------------	--	---------	-------

Undulating land. About 300 acres tea-tree, balance light bush. Soil of rather poor quality, on sandstone formation; well watered. Access from Mangapohue and Hauturu Roads, via Mangarere and Kokakoroa Roads.

14	XVI	Kawhia South		536 0 0	1 7 6
----	-----	--------------	--	---------	-------

Undulating land; small tea-tree; half ploughable. About 30 acres mixed bush. Poor soil, on sandstone formation; well watered. Access from Mangapohue and Hauturu Roads.

SECOND-CLASS LAND.

16	XVI	Kawhia South		431 2 0	2 5 0
----	-----	--------------	--	---------	-------

Good rich land; mostly heavy bush. Soil very good, on limestone formation; well watered. Access from Mangapohue and Hauturu Roads.

*Kinohaku West No. 3B.*

15	XVI	Kawhia South		365 0 0	2 0 0
----	-----	--------------	--	---------	-------

Easy to broken country. Half mixed bush, balance small tea-tree. Good soil, on limestone formation; well watered. Access from Mangapohue Road.

*Kinohaku West No. 1.*

THIRD-CLASS LAND.

2	XV	Kawhia South		337 2 20	1 5 0
---	----	--------------	--	----------	-------

Flat and undulating land. About 30 acres heavy bush, 60 acres light bush, and balance small tea-tree and gorse, with rich raupo swamp. Soil poor, on limestone and sandstone formation; well watered. Access from Mangapohue Road.

KAWHIA COUNTY.—AUCKLAND LAND DISTRICT.

*Aotea South No. 1 Block.*

SECOND-CLASS LAND.

1	I, II, V, and VI	Kawhia North		380 0 0	3 0 0
---	------------------	--------------	--	---------	-------

Situated on the southern side of the Aotea Harbour. All open country, steep in parts. About a mile and a half from Raglan-Kawhia Road. Access by beach. Loaded with £400 for improvements.

SECOND SCHEDULE.—LAND FOR LEASE.

Lot.	Block.	Survey District.	Area.	Upset Rental per Acre.
------	--------	------------------	-------	------------------------

WAITOMO COUNTY.—AUCKLAND LAND DISTRICT.

*Rangitoto-Tuhua Nos. 26A2, 26A3, 26B, 26D2, 35B2, and 35D, and Rangitoto A No. 42B.*

SECOND-CLASS LAND.

			A. R. P.	£ s. d.
24	IX	Mangaorongo	413 0 0	0 2 3

Undulating to easy fern land. Fair soil. Access from Otorohanga, seven miles, by formed road; also from Hangatiki, six miles.

25	IX	Mangaorongo	379 0 0	0 2 3
26	"	"	392 0 0	0 2 0

Undulating to easy fern land. Fair soil. Access from Otorohanga, eight miles; also from Hangatiki, about seven miles.

27	IX	Mangaorongo	473 1 0	0 2 0
----	----	-------------	---------	-------

Undulating to easy hilly fern land. Fair soil. Access from Otorohanga, twelve miles; also from Hangatiki, about eleven miles.

9	XIII	Mangaorongo	573 0 0	0 2 0
---	------	-------------	---------	-------

Undulating to easy hilly fern land. Fair soil. Access from Otorohanga, eight miles; also from Hangatiki, about seven miles.

THIRD-CLASS LAND.

10	XIII	Mangaorongo	343 0 0	0 1 9
----	------	-------------	---------	-------

Undulating to fair hilly fern land. Fair soil. About 100 acres mixed bush. Coal-bearing country. Access from Otorohanga, fourteen miles; also from Hangatiki, about thirteen miles.

11	XIII	Mangaorongo	292 0 0	0 1 9
----	------	-------------	---------	-------

Undulating to easy hilly fern land. Fair soil. Limestone in south-eastern end. About 80 acres mixed bush. Coal-bearing country. Access from Otorohanga, ten miles; from Hangatiki, about nine miles; and also from the Otewa-Ahuroa Road.

12	XIII	Mangaorongo	295 0 0	0 1 9
----	------	-------------	---------	-------

Easy hilly fern land. Fair soil. About 10 acres mixed bush, and probably 40 acres silver-wattles. Similar access to last section.

13	XIII	Mangaorongo	467 0 0	0 1 9
----	------	-------------	---------	-------

Fair hilly fern land. Fair soil. About 30 acres light bush. Access from Otorohanga, sixteen miles; and from Te Kuiti, about eight miles.

SECOND-CLASS LAND.

32B	X	Mangaorongo	908 2 7	0 2 3
-----	---	-------------	---------	-------

Undulating to hilly fern land. Fair soil. Access from Otorohanga, seven miles, by formed road and Native wagon-track.

42B	X	Mangaorongo	467 0 16	0 3 6
-----	---	-------------	----------	-------

Good section; partly improved river-flats. Rich soil. Fern flats, undulating fern hills, with some steep faces. Soil fair to very good. Right to remove Maori whares reserved. Grave to be kept fenced by lessee. Access from Otorohanga, about eight miles, by formed road and Native wagon-track. This section is loaded with £100 for improvements.

GENERAL DESCRIPTION.

The above sections adjoin the Rangitoto Improved-farm Settlement. The soil generally is fair to good, on a sandstone formation. All the sections are well watered.

ABSTRACT OF CONDITIONS.

Land for Sale.

1. Successful purchaser, on fall of hammer, to deposit a sum equal to 10 per cent of the price bid, and a fee of £3 3s. to meet costs and expenses incidental to the purchase, together with the amount with which the section is loaded for improvements (if any). The balance of the purchase-money to be paid in twenty equal half-yearly instalments.

2. The purchaser to pay interest on unpaid purchase-money at the rate of 5 per cent. per annum. Interest to be payable on the 1st July and 1st January of each year, and to date from the signing of contract of sale.

3. Purchaser shall, at the end of five years, upon payment of balance of purchase-money, be entitled to a transfer of the fee-simple of the land.

4. Residence and improvements to conform with sections 250 to 257 of the Native Land Act, 1909.

*Land for Lease.—Conditions of Lease (abridged).*

1. The term of the lease shall be twenty-three years from the 1st July, 1911, at the rental bid, with right of renewal for one further term of twenty-three years, at a rental assessed at 5 per cent. on the unimproved value of the land at the time of the renewal, such valuation, in the event of dispute, to be determined by arbitration. Compensation for substantial improvements shall be allowed to the lessee at the expiration of the second term of the lease, as provided in section 263 of the Native Land Act, 1909. Lessee shall be entitled to a rebate of rent for the period intervening between the date on which the section is allotted to him and the 1st January, 1912.

2. Residence to commence within four years in bush lands or swamp lands, and within one year in open or partly open lands, and to be continuous for six years.

3. Lessee has no right to minerals without license, but he may use on the land any minerals for any agricultural, pastoral, household, road-making, or building purposes.

4. Every lessee shall bring into cultivation,—

- (a.) Within one year from the date of his lease, not less than one-twentieth of the land leased by him;
- (b.) Within two years from the date of his lease, not less than one-tenth of the land leased by him;
- (c.) Within four years from the date of his lease, not less than one-fifth of the land leased by him;

and shall, within six years from the date of his lease, in addition to the cultivation of one-fifth of the land, have put substantial improvements of a permanent character (as defined by the Land Act, 1908) on first-class land to the value of £1 for every acre of such land, and on second-class land to an amount equal to the net price of every acre of such land: Provided that in no case shall the additional improvements required on second-class land be more than 10s. per acre, or 2s. 6d. on third-class land.

5. (a.) Rent shall be payable half-yearly in advance.

(b.) Lessee will not assign the lease without the consent of the Board.

(c.) Lessee will cultivate the land in a husbandlike manner, and keep it free from noxious weeds.

(d.) Lessee will keep fences and buildings in repair.

(e.) Lessee will fence without any right of resort to the Board for contribution on account of the Board owning or occupying adjacent land; but this provision shall not deprive the lessee of any rights he may have against any subsequent occupier other than the Board of such adjacent land.

(f.) A copy of the form of lease can be inspected at the office of the Under-Secretary of Native Affairs, Wellington, or the office of the Board.

**GENERAL INSTRUCTIONS TO SELECTORS.**

1. The lands to be sold or leased subject to reserve price or rental specified in each case.

2. Successful lessees, on fall of hammer, to deposit six months' rent, lease fee (£3 3s.), an amount sufficient to cover stamp duty and registration fee, and the amount with which the section is loaded for improvements (if any). NOTE.—Stamp duty will be 5s. if rent under £50 per annum, with an additional 2s. 6d. for each further £50 or fraction thereof; registration fee is uniformly 10s.

3. The highest bidder to be declared the purchaser or lessee, but the Board reserves to itself the right to decline to accept any bid.

4. The successful purchaser or lessee will require to make declaration of qualification under the Native Land Act, within thirty days, to the effect that he is not the owner or occupier of 3,000 acres of third-class land, or its equivalent in other classes of land.

5. The lands are offered under the Native Land Act, 1909, and the regulations made thereunder, and purchasers and lessees shall be deemed to be acquainted with the provisions thereof, and be bound thereby as effectually as if such provisions were embodied herein.

The lands are described for the general information of intending selectors, who are recommended, nevertheless, to make a personal inspection, as the Board is not responsible for the absolute accuracy of any description.

Full particulars may be obtained at the office of the Under-Secretary for Native Affairs, Wellington, and at the office of the Waikato-Maniapoto District Maori Land Board, Auckland.

W. H. BOWLER,  
President, Waikato-Maniapoto District  
Maori Land Board.

**BANKRUPTCY NOTICES.**

*In Bankruptcy.*

NOTICE is hereby given that dividends are now payable in the undermentioned estates on all proved claims. Promissory notes (if any) to be produced for indorsement prior to receiving dividend.

Johnson, Bros., of Waitekauri, Fruiterers, &c.: Supplementary, 2s. 6d. in the pound.

Coutts, A., late of Tauranga, Brewer: First, 2s. in the pound.

Elliott, R., of Whangarei, Baker: Second, 7s. 6d. in the pound.

Bishara, S., of Whangamomona, Storekeeper: First and final, 2s. 0½d. in the pound.

Borne, D., of Auckland, Builder: Supplementary, 6s. 9d. in the pound.

W. S. FISHER,  
Official Assignee.

Auckland, 1st November, 1911.

*In Bankruptcy.—In the Supreme Court, holden at Auckland.*

NOTICE is hereby given that WILLIAM WHITBREAD, of Ponsonby, Auckland, Grocer and Fruiterer, was this day adjudged bankrupt; and I hereby summon a meeting of creditors, to be holden at my office, on Friday, the 17th day of November, 1911, at 11 a.m.

W. S. FISHER,  
Official Assignee.

Auckland, 11th November, 1911.

*In Bankruptcy.—In the Supreme Court, holden at Gisborne.*

NOTICE is hereby given that FREDERICK JAMES PARSONS, of Ormond, Labourer, was this day adjudged bankrupt; and I hereby summon a meeting of creditors, to be holden at my office, on Tuesday, the 14th day of November, 1911, at 2.30 o'clock.

JOHN COLEMAN,  
Deputy Official Assignee.

Gisborne, 6th November, 1911.

*In Bankruptcy.*

In the estate of GEORGE WILLIAM LAWRENCE, of New Plymouth, a bankrupt.

NOTICE is hereby given that a first and final dividend, on all proved and accepted claims, of 4s. 1d. in the pound is now payable at my office, New Plymouth. Promissory notes (if any) must be produced for indorsement.

J. S. S. MEDLEY,  
Deputy Official Assignee.

New Plymouth, 10th November, 1911.

*In Bankruptcy.—In the Supreme Court, holden at New Plymouth.*

NOTICE is hereby given that the following dividends are now payable, on all proved and accepted claims, at my office, Stratford. Promissory notes (if any) to be produced for indorsement prior to payment of dividend.

Estate of Elias Fredrick Franzen, of Midhirst, Grocer: Second and final of 1s. in the pound, making a total of 14s. 11d. in all.

Estate of John Joseph Bourke, Baker, of Stratford: First and final dividend of 4d. in the pound.

ALFRED COLEMAN,  
Deputy Official Assignee.

Stratford, 14th November, 1911.



*In Bankruptcy.—In the Supreme Court, holden at Wellington.*

NOTICE is hereby given that statements of accounts and balance-sheets in respect of the undermentioned estates, together with the report of the Audit Office thereon, have been duly filed in the above Court; and I hereby further give notice that at the sitting of the said Court to be holden on Monday, the 4th day of December, 1911, I intend to apply for an order releasing me from the administration of the said estates.

Dated this 14th day of November, 1911.

644. Oakley, Henry Josiah.  
659. Fear, George.  
673. Edmonds, Arthur Edward.  
677. Low, Robert.  
681. Walden, Jane.  
683. Smith, William.  
693. Newson, Charles Sebastian.  
698. Crawford, William Gore.  
706. Guest, Henry.  
725. Howan, Samuel, jun.  
726. Orsborn, Garrod.  
744. Josephs, Philip.  
751. Pacey, William.  
758. Taylor, John Henry.  
761. Wilton, Clarence Arthur.  
762. Harvey, George Willis.  
766. Yarrow, Robert.  
774. Clark, Thomas Matthew.  
783. Adams, Matthew.  
783. Adams, Matthew and Mary.  
783. Adams, Mary Alice.  
786. Botterill, Thomas George.  
787. Rider, John Neil.  
791. Morris, George.  
792. Petty, Fanny.  
799. Johnston, Richard Owen.  
804. Gelhor, Israel.  
806. Imrie, William Matthew.  
810. Hawley, Cecil Luscombe.  
813. Hutchings, William Bishop Black.  
817. White, John.  
824. Cullen, Caroline.  
832. Matthews, Frank C.  
843. Bell, Reginald.  
849. Holmes, John.  
855. Bateman, William Edwin.  
856. O'Sullivan, Daniel Frances.  
868. Turner, Donald Langley.  
869. Stevens, Charles Douglas.  
874. Olivecrona, Charles John.  
879. Brady, William Joseph.  
883. White, Abraham.  
890. Murdoch, John Hardie.

ALEX. SIMPSON,  
Official Assignee.

*In Bankruptcy.—In the Supreme Court, holden at Christchurch.*

NOTICE is hereby given that statements of accounts and balance-sheets in respect of the undermentioned estates, together with the report of the Audit Office thereon, have been duly filed in the above Court; and I hereby further give notice that at the sitting of the said Court to be holden on Tuesday, the 28th day of November, 1911, I intend to apply for an order releasing me from the administration of the said estates.

Dated this 13th day of November, 1911.

Ovenden, W. H.	Humm, S.
Willa, George.	Anderson, D.
Lunt, Fred.	Walker, L.
Weston, James.	Beaumont, A. W.
Barker, B.	Withers, Wm.
Lyttelton Steam Laundry Company (in liquidation).	Webb, G. C.
Lamb, C. G.	Thompson and Paterson.
Horneman, J. E.	Thompson, Jas.
Ring, P. A.	Paterson, A.
Thompson, Hy.	Ramsay, W. E.
Chapman, E. A.	Cairns, A. J.
Parry, T. G. A.	Aitken, T. H.
Cotton, T. W.	Matthews, J. W.
	Bevins, Geo.

J. EVANS,  
Official Assignee.

*In Bankruptcy.—In the Supreme Court, holden at Greymouth.*

NOTICE is hereby given that EDGAR JAMES LOW and ETHELBERT WILLIAM LOW, carrying on business in co-partnership as "Low Brothers," of Kokiri, Storekeepers, were this day adjudged bankrupt; and I hereby summon a meeting of creditors, to be holden at my office, on Friday, the 17th day of November, 1911, at 2.30 o'clock p.m.

C. W. COOKE,  
6th November, 1911. Deputy Official Assignee.

### LAND TRANSFER ACT NOTICES.

NOTICE is hereby given that the several parcels of land hereinafter described will be brought under the provisions of the Land Transfer Act, 1908, unless caveat be lodged forbidding the same within one month from the date of the *Gazette* containing this notice.

5183. EDWIN CHARLES MARTIN.—Allotment 60 and part Allotment 59, Parish of Koheroa, containing 130 acres and 7 perches. Occupied by J. Tichloff.

5200. HENRY JEFFRIES.—Parts of Allotments 5, 102, and 125A, Parish of Waipipi, containing 107 acres and 19.4 perches. Occupied by Applicant.

5204. JAMES WILLIAM RAWNSLEY.—Part Lot 12, Section 1, of Allotments 20 and 21, Section 10, Suburbs of Auckland, containing 2 roods 16.5 perches. Occupied by Applicant.

Diagrams may be inspected at this office.

Dated this 13th day of November, 1911, at the Lands Registry Office, Auckland.

THOS. HALL,  
District Land Registrar.

NOTICE is hereby given that the parcel of land hereinafter described will be brought under the provisions of the Land Transfer Act, 1908, unless caveat be lodged forbidding the same on or before the 21st day of December, 1911.

FELIX TEMPLEMAN BELLINGER.—Section 1316, Town of New Plymouth. Occupied by Applicant. No. 1249.

Diagram may be inspected at this office.

Dated this 12th day of November, 1911, at the Lands Registry Office, New Plymouth.

A. V. STURTEVANT,  
Assistant Land Registrar.

NOTICE is hereby given that the parcel of land hereinafter described will be brought under the provisions of the Land Transfer Act, 1908, unless caveat be lodged forbidding the same on or before the 16th day of December, 1911.

Application 4452 (Plan A/2949). THE WESTPORT COAL COMPANY (LIMITED).—1 rood 7.5 perches, part Section 727, Wellington. Occupied by Applicant.

Diagram may be inspected at this office.

Dated this 15th day of November, 1911, at the Lands Registry Office, Wellington.

G. G. BRIDGES,  
District Land Registrar.

APPLICATION having been made to me to register a re-entry by CHARLES UDY, of Hukanui, Farmer, as lessor under Memorandum of Lease No. 6873, affecting 205 acres 2 roods 18 perches, being Sections 11 and 12 of Block III, Mangahao Survey District, comprised in certificates of title Vol. 77, folio 180, and Vol. 89, folio 54, of which JOHN STOBIE, of Tokomaru, Farmer, is the registered lessee, I hereby give notice that I will register the re-entry as requested, unless caveat be lodged forbidding the same on or before the 16th day of December, 1911.

Dated this 15th day of November, 1911, at the Lands Registry Office, Wellington.

G. G. BRIDGES,  
District Land Registrar.

**N**OTICE is hereby given that the parcel of land herein after described will be brought under the provisions of the Land Transfer Act, 1908, unless caveat be lodged forbidding the same on or before the 15th day of December, 1911.

No. 670. RICHARD McCALLUM and ARCHIBALD McCALLUM.—21 acres 2 roods 10'6 perches, parts of Section 50, District of Omaka (Borough of Blenheim). Occupied by Applicants.

Diagram may be inspected at this office. D.P. 538.

Dated this 13th day of November, 1911, at the Lands Registry Office, Blenheim.

R. STONE FLORANCE,  
District Land Registrar.

**N**OTICE is hereby given that the several parcels of land hereinafter described will be brought under the provisions of the Land Transfer Act, 1908, unless caveat be lodged forbidding the same within one month from the date of the *Gazette* containing this notice.

10892. SAMUEL GREEN.—33 acres 3 roods 5 perches, part of Rural Section 13950, Block XVI, Pareora Survey District. Occupied by Applicant.

11519. JOHN WESLEY TOPHAM.—218 acres 1 rood 8 perches, part of Rural Section 4225, Block VI, Arowhenua Survey District. Occupied by Applicant.

11521. WILFRID STUART GODFREY.—1 rood 32 perches, part of Rural Section 325, Block XI, Christchurch Survey District. Occupied by Applicant.

Diagrams may be inspected at this office.

Dated this 14th day of November, 1911, at the Lands Registry Office, Christchurch.

W. WYINKS,  
District Land Registrar.

**E**VIDENCE having been furnished of the loss of certificate of title, Vol. 80, folio 114, for Section 5, Block XV, Waihola District, whereof ARCHIBALD CARRICK, of Waihola, Farmer, is the registered proprietor, and application having been made to me to issue a provisional certificate of title for the said land, I hereby give notice of my intention to issue such provisional certificate at the expiration of fourteen days from the date of the publication hereof.

Dated at the Lands Registry Office, Dunedin, this 10th day of November, 1911.

C. E. NALDER,  
District Land Registrar.

**N**OTICE is hereby given that the several parcels of land hereinafter described will be brought under the provisions of the Land Transfer Act, 1908, unless caveat be lodged forbidding the same within one month from the publication hereof.

ARCHIBALD MILLER.—Sections 15 and 16, Upper Harbour West District. Unoccupied. No. 5031.

WILLIAM PICKWORTH.—Allotment 1, Block X, subdivision of part of Section 5, Block XXXV, Clutha District. Occupied by Alexander Noble. No. 5032.

Diagrams may be inspected at this office.

Dated this 10th day of November, 1911, at the Lands Registry Office, Dunedin.

C. E. NALDER,  
District Land Registrar.

**N**OTICE is hereby given that the parcel of land herein after described will be brought under the provisions of the Land Transfer Act, 1908, unless caveat be lodged forbidding the same on or before the 18th day of December, 1911.

2954. EMMA WOHLERS.—1 acre 1 rood 36 perches, part Section 33, Block XIX, Invercargill Hundred. Occupied by Florinda Jane Harper and Joseph William Harper.

Diagram may be inspected at this office.

Dated this 8th day of November, 1911, at the Lands Registry Office, Invercargill.

L. PAULING,  
District Land Registrar.

## MINING NOTICES.

**N**OTICE is hereby given that the following resolution has been carried by the shareholders of the Tararu Mines (Limited) at a meeting held on the 31st August, 1911:—

“That it is proved to the satisfaction of the meeting that the company cannot, by reason of its liabilities, continue its business, and that it is advisable to wind up the same under the provisions of the Companies Act, 1908; and that WILLIAM GRAY, of Auckland, Company Secretary, be appointed Liquidator.”

691

WM. GRAY, Liquidator.

In the matter of the SKIPPERS SLUICING COMPANY (LIMITED).

**A**T an extraordinary general meeting of the above-named company duly convened and held at the registered office of the company at No. 11 Crawford Street, Dunedin, on Tuesday, the 26th day of September, 1911, the following resolutions, of which notice had been given, were duly proposed and carried:—

1. “That it has been proved to the satisfaction of this meeting that the company, by reason of its liabilities, cannot continue its business, and that it is advisable to wind up the same; and that accordingly the company be wound up voluntarily.”
2. “That Mr. WILLIAM THOMSON is hereby appointed Liquidator of the company.”

Dated at Dunedin, this 10th day of November, 1911.

692

A. BATHGATE,  
Chairman.

## PRIVATE ADVERTISEMENTS.

IN THE SUPREME COURT OF NEW ZEALAND,  
NORTHERN DISTRICT.

In the matter of the Administration Act, 1908; and in the matter of the estate of FRANZ SCHERFF, late of Jermyn Street, in the City of Auckland, Merchant, deceased.

**I** HEREBY give notice that by Order of the Supreme Court, Auckland, dated Monday, the 30th day of October, 1911, I was appointed Administrator of the estate of the above-named FRANZ SCHERFF, deceased; and I hereby call a meeting of creditors, to be held at my office, on Tuesday, the 21st day of November, 1911, at 11 a.m.

All claims against the above estate must be lodged with me on or before the 30th day of December, 1911.

Auckland, 14th day of November, 1911.

W. S. FISHER,  
Official Assignee, Administrator.

**N**OTICE is hereby given that the Partnership lately existing between ERNEST HENRY HAWKINS and ROBERT ALEXANDER JACKSON, of Mamaku, Butchers and Horse-breeders, under the name of “Hawkins and Jackson,” has been dissolved by mutual consent as from the 1st October, 1911.

686

E. H. HAWKINS.  
R. A. JACKSON.

**A**T an extraordinary general meeting of the members of PAUL BOCK AND CO. (LIMITED), Manufacturers, duly convened and held at Auckland on the 30th day of October, 1911, the following extraordinary resolution was duly passed: “That the company be wound up voluntarily.” And at the same meeting JAMES HENRY MACKIE, F.P.A.N.Z., Public Accountant, Auckland, was appointed Liquidator for the purpose of such winding-up.

Dated at Auckland, this 2nd day of November, 1911.

PAUL BOCK, Chairman.  
Witness—Sarah Fegan, Clerk, Auckland. 687

NOTICE OF DISSOLUTION OF PARTNERSHIP.

NOTICE is hereby given that the Partnership hitherto subsisting between us, the undersigned, JENS JENSEN, JOHN NORMAN ARNDT PEDERSEN, and ROBERT DICKSON, in the business of sawmillers, carried on by us at Raetihi, under the style or firm of "Jensen and Company," has been dissolved as regards the said JENS JENSEN as from the 1st day of September, 1911; and that the said business will in future be carried on in partnership by the said JOHN NORMAN ARNDT PEDERSEN and ROBERT DICKSON, who will discharge all the liabilities of the old firm.

Dated this 2nd day of October, 1911.

J. JENSEN.

Witness to the signature of Jens Jensen—R. J. Loughnan, Solicitor, Taihape.

J. N. A. PEDERSEN.  
ROBERT DICKSON.

Witness to the signatures of John Norman Arndt Pedersen and Robert Dickson—W. H. Tustin, Solicitor, Raetihi.

688

LINTON HEMP COMPANY (LIMITED).

NOTICE is hereby given, in pursuance of section 230 of the Companies Act, 1908, that a general meeting of the members of the above-named company will be held at the office of Messrs. LOUGHNAN AND JACOBS, Solicitors, Rangitikei Street, Palmerston North, on Friday, the 1st day of December, 1911, at 10.30 o'clock in the forenoon, for the purpose of having an account laid before them showing the manner in which the winding-up has been conducted and the property of the company disposed of, and of hearing any explanation that may be given by the Liquidator; and also of determining by extraordinary resolution the manner in which the books, accounts, and documents of the company and of the Liquidator thereof shall be disposed.

Dated the 14th day of November, 1911.

R. MACKAY,  
Liquidator.

Witness—R. Whitaker, Law Clerk, Palmerston North.

694

NOTICE is hereby given that the Partnership heretofore subsisting between PETER URLICH and GEORGE STEVE URLICH, carrying on business at Kaiwaka, in the Provincial District of Auckland, as Storekeepers, has been dissolved as from the fourth day of May, one thousand nine hundred and eleven.

Dated this 7th day of September, 1911.

PETER URLICH.

Signed by the said Peter Urlich in the presence of—C. J. Tunks, Solicitor, Auckland.

G. S. URLICH.

Signed by the said George Steve Urlich in the presence of—A. F. Billing, Solicitor's Clerk, Auckland.

689

MEDICAL REGISTRATION.

ALEXANDER CAMERON MCKILLOP, M.B., Bac. Surg., 1909, Univ. Edin., now residing in Wellington, hereby give notice that I intend applying on the 14th December next to have my name placed on the Medical Register for the Dominion of New Zealand; and that I have deposited the evidence of my qualification in the office of the Registrar-General.

A. C. MCKILLOP.

Dated at Wellington, 14th November, 1911.

690

THE PHARMACY BOARD OF NEW ZEALAND.

NOTICE is hereby given that, pursuant to notice dated the 28th day of September, 1911, under my hand, the following persons, being eligible, were respectively nominated as candidates for election to represent the respective districts hereinafter mentioned as members of the Pharmacy Board of New Zealand; and the number of nominations not exceeding the number of vacancies to be filled in the case of each respective district, the said persons are hereby declared to have been duly elected members of the said Board, to hold office as from the 1st day of January, 1912.

The District of Auckland—  
TEED, DAVID, JUN.  
WOOLLAMS, WILLIAM HENRY.

The District of Canterbury—  
BARRETT, WILLIAM.  
BONNINGTON, LEONARD.

The District of Otago—  
HASLETT, JAMES ALEXANDER.  
SCHOFELD, BENJAMIN SMITH.

And it is further notified that, pursuant to the said notice, the following candidates, being eligible, were duly nominated for election to represent the Central District (Wellington District) as members of the said Board, and at the election duly held on the 27th day of October, 1911, the votes cast were—

Castle, Frederick	...	...	...	88
Bagley, George	...	...	...	87
Davies, Ernest Bertram	...	...	...	46
Watson, James Ernest	...	...	...	7
Informal	...	...	...	3

And I hereby declare the said FREDERICK CASTLE and GEORGE BAGLEY to have been duly elected to represent the Central District (District of Wellington) upon the said Board as from the 1st day of January, 1912.

Dated at Wellington, the 10th day of November, 1911.

C. W. NIELSEN,  
Registrar.

693

OPUHI FIBRE COMPANY (LIMITED).

NOTICE is hereby given, in pursuance of section 230 of the Companies Act, 1908, that a general meeting of the members of the above-named company will be held at the office of Messrs. LOUGHNAN AND JACOBS, Solicitors, Rangitikei Street, Palmerston North, on Friday, the 1st day of December, 1911, at 10.30 o'clock in the forenoon, for the purpose of having an account laid before them showing the manner in which the winding-up has been conducted and the property of the company disposed of, and of hearing any explanation that may be given by the Liquidator; and also of determining by extraordinary resolution the manner in which the books, accounts, and documents of the company and of the Liquidator thereof shall be disposed.

Dated the 14th day of November, 1911.

R. MACKAY,  
Liquidator.

Witness—R. Whitaker, Law Clerk, Palmerston North.

695

NOTICE is hereby given that the business of Sawmillers and Timber-merchants hitherto existing between the undersigned has been dissolved as from the date hereof. The business shall, as from this date, be carried on by Mr. JOHN WILKINSON, who shall receive all accounts due to the said firm of McKinstry and Wilkinson, and pay all liabilities of the said firm.

Dated this 7th day of November, 1911.

W. MCKINSTRY.  
JOHN WILKINSON.

Witness—H. R. Kirker, Solicitor, Whangarei.

696

COOK COUNTY COUNCIL.

REGISTRATION OF MOTORS.

PURSUANT to the provisions of Part II of the Motor Regulation Act, 1908, notice is hereby given that this Council did, by resolution passed at a special meeting of the Council held on the 30th October, 1911, decide that Part II of the Motor Regulation Act, 1908, shall be brought into operation in the County of Cook on the first day of December, one thousand nine hundred and eleven.

It is proposed to charge a registration fee of ten shillings upon all motor carriages having four wheels, and a fee of five shillings upon motors having less than four wheels.

JOHN WARREN,  
Clerk.

Gisborne, 2nd November, 1911.

697

NOW READY.

THE NEW ZEALAND OFFICIAL YEAR-BOOK.  
1910.

Containing latest information, Historical, Political, Official, Statistical, Industrial, Commercial, &c.: Digest of Land Laws and Description of Land Districts.

PRICES: PAPER COVER, 1s.; CLOTH BOARDS, 2s.

## THE NEW ZEALAND GAZETTE.

**SUBSCRIPTIONS.**—The subscription is at the rate of 33s. per annum, including postage, PAYABLE IN ADVANCE. A less period than three months cannot be subscribed for.

Single copies of the *Gazette*, 6d. each.

Advertisements are charged at the rate of 6d. per line for the first insertion, and 3d. per line for the second and any subsequent insertion.

Statements under the Mining Act are uniformly charged 23s.

All advertisements should be written on one side of the paper, and signatures, &c., should be written in a legible hand.

The number of insertions required must be written across the face of the advertisement.

The *New Zealand Gazette* is published on Thursday evening in each week, and notices for insertion must be received by the Government Printer before 3 o'clock of the day preceding publication.

Communications should be addressed to the Government Printer, Wellington, to whom post-office money-orders should be made payable. Cheques should be crossed "Public a/c," and exchange added.

Postage or duty stamps cannot be received in payment from any place at which postal notes or post-office orders are issued.

Prepayment may be demanded in any case. In order to prevent delay in publication, a sufficient remittance should accompany every advertisement. Any surplus will be returned with receipted account.

## SCHOOL FOR DEAF-MUTES, SUMNER, NEAR CHRISTCHURCH.

*Under the Control and Supervision of the Education Department.*

Director: MR. J. E. STEVENS.

**F**OR Deaf Children of sound intellect. The pupils are taught to use and understand ordinary speech. The full charge for board and education is £40 a year, but less is accepted from parents who cannot afford to pay this amount. In case of necessity admission is free.

By the Education Act, the education of deaf children between the ages of 7 and 16 is made compulsory. A child is, as a rule, best fitted to begin the school course at about the age of six, but advice should be obtained as soon as any sign of deafness is observed.

The following classes of deaf children are admitted:—

1. Children born deaf, or who have lost their hearing before learning to speak.
2. Children who can hear a little, but are too deaf to be taught in an ordinary school.
3. Children who have lost their hearing after having learned to speak.

Parents and other persons acquainted with such cases above the age of 4 are invited to communicate with the Director, or with

THE SECRETARY FOR EDUCATION,  
Wellington.

## AWARDS, RECOMMENDATIONS, AND DECISIONS UNDER THE INDUSTRIAL CONCILIATION AND ARBITRATION ACT.

SUBSCRIPTION, 3s. 6d. PER ANNUM, INCLUDING POSTAGE.

## JOURNAL OF THE DEPARTMENT OF LABOUR.

PUBLISHED MONTHLY.

SUBSCRIPTION, 2s. 6d. PER ANNUM, INCLUDING POSTAGE.

## JOURNAL OF THE DEPARTMENT OF AGRICULTURE.

PUBLISHED MONTHLY.

SUBSCRIPTION, 2s. 6d. PER ANNUM, INCLUDING POSTAGE.  
SINGLE COPY, 6d.

**S**UBSCRIPTIONS should be forwarded by postal note or stamps (preferably the former) to the Editor, Publications Section, Department of Agriculture, Wellington. Subscribers should furnish full name and address.

## CONTENTS.

	PAGE
APPOINTMENTS .. .. .	3398
BANKRUPTCY NOTICES .. .. .	3432
CROWN LANDS NOTICES .. .. .	3415
DEFENCE FORCES .. .. .	3398
LAND—	
Boundaries of Maori Village amended .. .. .	3405
National Endowment, for Selection .. .. .	3396
Post-office, Taken for a .. .. .	3395
Public Trustee, Notice by .. .. .	3408
Renewable Lease, Selection on .. .. .	3395
Reserved temporarily .. .. .	3397
Road, Allocating Land reserved for a Railway to the Purposes of a .. .. .	3394
Road, Laying-out and taking .. .. .	3393
Roads proclaimed and closed .. .. .	3394
Sale by Public Auction .. .. .	3396
Scenery-preservation, Notice of Intention to take Land for .. .. .	3407
Selection, Set apart for .. .. .	3393
Streets, Authorizing the Laying-off of .. .. .	3404
LAND TRANSFER ACT NOTICES .. .. .	3433
MAORI LAND ADMINISTRATION NOTICES .. .. .	3425
MINING NOTICES .. .. .	3434
MISCELLANEOUS—	
Bonding Warehouse approved and appointed .. .. .	3407
Bonding Warehouse, Revocation of Appointment of .. .. .	3407
Census, 1911: Poultry and Bee-keeping .. .. .	3414
Commissioners appointed to classify Pastoral Runs .. .. .	3398
Despatch: Convention to amend Extradition Treaty with Belgium .. .. .	3406
Friendly Society registered .. .. .	3414
Holiday: St. Andrew's Day .. .. .	3400
Immigration and Emigration Returns .. .. .	3413
Naturalization, Letters of, issued .. .. .	3400
Officiating Ministers for 1911 .. .. .	3414
Officiating Ministers, Religious Bodies required to furnish Lists of .. .. .	3414
Opium, Permits to import .. .. .	3408
Opossums to be deemed Imported Game .. .. .	3395
Polls for Proposed Loans .. .. .	3402
Population of the Dominion .. .. .	3413
Public Libraries, Subsidies to .. .. .	3408
Railways, Alterations to Scale of Fares, &c. .. .. .	3405
Railway Traffic Returns .. .. .	3409
Resolutions under the Local Bodies' Loans Act .. .. .	3401
Special Order .. .. .	3401
Tenders .. .. .	3408
NATIVE LAND COURT NOTICES .. .. .	3420
PRIVATE ADVERTISEMENTS .. .. .	3434
SHIPPING—	
Notices to Mariners .. .. .	3405

## 30th November to be a Holiday in Celebration of St. Andrew's Day.

Office of the Minister of Internal Affairs, Wellington, 11th November, 1911.

THE Government offices throughout New Zealand will be closed on Thursday, 30th November, 1911, in celebration of St. Andrew's Day.

D. BUDDO,  
Minister of Internal Affairs.

## Patent Office Agents appointed.

Department of Justice,  
Wellington, 11th November, 1911.

HIS Excellency the Governor has been pleased to appoint

FRANK MITCHELL

to be Patent Office Agent at Taihape,

JOSEPH MARTIN RODGERS

to be Patent Office Agent at Invercargill during the absence of J. R. Colyer, and

JULIUS CÆSAR MALFROY

to be Patent Office Agent at Oamaru during the absence of A. A. Mair.

JOHN G. FINDLAY.

## Applications for Letters Patent filed.

LIST of applications for Letters Patent filed. (Where a complete specification accompanies an application an asterisk is affixed; in all other cases a provisional specification has been lodged. In all cases where the applicant is not the inventor the name of the latter appears in italics in brackets. † Denotes an application under the International and Intercolonial Arrangements.)

Cuddy, A. C. J., Christchurch, N.Z. .. .. .	..	..	Cricket-bat; 30424; 27th October.
Wood, W. G., Christchurch, N.Z. .. .. .	..	..	Cricket-bat; 30424; 27th October.
Broughton, E., Auckland, N.Z. .. .. .	..	..	Bicycle-tire inner tube; 30425; 24th October.
East, J., Gisborne, N.Z. .. .. .	..	..	Fencing-dropper, &c.; 30426; 28th October.
Bull, J. E., New Plymouth, N.Z. .. .. .	..	..	Tire-puncture detector; 30427; 28th October.
Burrows, P. F., New Plymouth, N.Z. .. .. .	..	..	Hatpin; 30428; 28th October.
Peterson, S. B., Oamaru, N.Z. .. .. .	..	..	Window-draught, &c., prevention; 30429; 28th October.
Tate, J., East Malvern, Vic. ( <i>McManus, J.</i> ) .. .. .	..	..	Milk-strainer*; 30430; 27th October.
Wilbuschewitsch, M., Nischninowgorod, Russia .. .. .	..	..	Fat-melting-point raising*; 30431; 17th December, 1910.†
Wilbuschewitsch, M., Nischninowgorod, Russia .. .. .	..	..	Fats, refining*; 30432; 30th January.†
Johnson, C. C., Ashburton, N.Z. .. .. .	..	..	Window-stay; 30433; 30th October.
Fitchett, W. H., Shannon, N.Z. .. .. .	..	..	Flower-carrier; 30434; 31st October.
Schwer, E., Enmore, N.S.W. .. .. .	..	..	Bath, &c., water-heater*; 30435; 31st October.
Theyers, D., Auckland, N.Z. .. .. .	..	..	Writing-tablet cover; 30436; 30th October.
Joy, W. G., Auckland, N.Z. .. .. .	..	..	Floor-polisher; 30437; 30th October.
Collett, S. M., Timaru, N.Z. .. .. .	..	..	Woolpack-clamp; 30438; 1st November.
Morris, R. T., Manhattan, U.S.A. .. .. .	..	..	Tobacco-pipe*; 30439; 30th November, 1910.†
Deister, E., Fort Wayne, U.S.A. .. .. .	..	..	Ore-concentrator*; 30440; 30th October.
Glass, J. W., Henley, N.Z. .. .. .	..	..	Rubber stamp*; 30441; 30th October.
Scott, S. A., Dunedin, N.Z. .. .. .	..	..	Ball cock*; 30442; 30th October.
Glass, J. W., Henley, N.Z. .. .. .	..	..	Cheese-making cloth; 30443; 30th October.
Holden, W. E., Auckland, N.Z. .. .. .	..	..	Advertising apparatus; 30444; 1st November.
Stewart, R. P., Gisborne, N.Z. .. .. .	..	..	Hydraulic driving of engines; 30445; 1st November.
Hart, J. A., Blackburn, Eng. .. .. .	..	..	Gas-compressor*; 30446; 1st November.
Jones, D., Whangarei, N.Z. .. .. .	..	..	Steam-generator furnace; 30447; 1st November.
Hill, R. P., Auckland, N.Z. .. .. .	..	..	Lock; 30448; 31st October.
Roos, E., Sydney, N.S.W. ( <i>Shaw, C. H.</i> ) .. .. .	..	..	Cream-separator; 30449; 2nd November.
Thew, H. G., Auckland, N.Z. .. .. .	..	..	Gas-lighter; 30450; 1st November.
Wynyard, M. H., Auckland, N.Z. .. .. .	..	..	Flax blade tail treating; 30451; 31st October.
Wynyard, M. H., Auckland, N.Z. .. .. .	..	..	Flax-dresser; 30452; 31st October.
Thackray, S. A., Manawaru, N.Z. .. .. .	..	..	Medicine*; 30453; 3rd November.
Rasmussen, J. B., Dannevirke, N.Z. .. .. .	..	..	Motor-car-lamp bracket; 30454; 3rd November.
McPherson, F., Leamington, N.Z. .. .. .	..	..	Fence-dropper; 30455; 3rd November.
Whiteside, A. J., Raupo, N.Z. .. .. .	..	..	Flax-dresser, &c.; 30456; 2nd November.
Dudfield, W. G., Melbourne, Vic. .. .. .	..	..	Blanket antiseptic treatment*; 30457; 4th November.
Kettle, F., Dunedin, N.Z. .. .. .	..	..	Grat., &c., heater; 30458; 2nd November.
Brown, J. E. C., Okeake, N.Z. .. .. .	..	..	Venetian-blind; 30459; 2nd November.
Bicknell, P. E., Auckland, N.Z. .. .. .	..	..	Tie exhibitor*; 30460; 3rd November.
Nicoll, G., Auckland, N.Z. .. .. .	..	..	Sighting-level; 30461; 6th November.
Stevenson, J. D., Waitomo Caves, N.Z. .. .. .	..	..	Plough; 30462; 6th November.
Stroud, J., Oamaru, N.Z. .. .. .	..	..	Cooking utensil; 30463; 6th November.
Henderson, W., Oamaru, N.Z. .. .. .	..	..	Cooking utensil; 30463; 6th November.
Bettini, G., Paris, France .. .. .	..	..	Cinematograph*; 30464; 9th November, 1910.†
Higbee, O. J. W., Bridg-ville, U.S.A. .. .. .	..	..	Vacuum wall receptacle*; 30465; 29th November, 1910.†
Armstrong, E. J., Eltham, N.Z. .. .. .	..	..	Teat-cup; 30466; 7th November.
Davy, C. F., Fitzroy, N.Z. .. .. .	..	..	Non-refillable bottle; 30467; 7th November.
Richardson, T., Fitzroy, N.Z. .. .. .	..	..	Non-refillable bottle; 30467; 7th November.
Ormiston, J., Dunedin, N.Z. .. .. .	..	..	Steam-boiler; 30468; 7th November.
Pierce, W. J., Napier, N.Z. .. .. .	..	..	Vehicle-brake; 30469; 8th November.
Cunningham, T., Napier, N.Z. .. .. .	..	..	Vehicle-brake; 30469; 8th November.
Pearce, F., Invercargill, N.Z. .. .. .	..	..	Wool-bale grip; 30470; 6th November.
Robertson Marine Engine Brake Company, Limited, Timaru, N.Z. ( <i>Robertson, A. C.</i> ) .. .. .	..	..	Steam-engine-speed controller, &c.; 30471; 8th November.
Brown, F. E., Sydney, N.S.W. ( <i>White, W.</i> ) .. .. .	..	..	Gas-stove*; 30472; 8th November.
Nightingall, V., Melbourne, Vic. .. .. .	..	..	Electric-heater heat-controller*; 30473; 8th November.
Davidson, G., Dunedin, N.Z. .. .. .	..	..	Trolley-pole-point shifter; 30474; 7th November.
Sander, E. G., Westport, N.Z. .. .. .	..	..	Moustache-guard for cup; 30475; 2nd November.
Mander, H., Te Kaha, N.Z. .. .. .	..	..	Moustache-guard for cup; 30475; 2nd November.
Hunter, W. E., Mauugakarama, N.Z. .. .. .	..	..	Clothes-peg; 30476; 2nd November.
Canfield, R. A., Rhode Island, U.S.A. ( <i>Dorman, W. S., and Manville, R. C.</i> ) .. .. .	..	..	Stopper-making machine*; 30477; 9th November.
Symons, A. T. G., Christchurch, N.Z. .. .. .	..	..	Golf-club, &c.; 30478; 9th November.
Davis, C. H., Wanganui, N.Z. .. .. .	..	..	Milk-releaser*; 30479; 9th November.
Widerstrom, U. T. G., Port Ahuriri, N.Z. .. .. .	..	..	Tent, &c., pole*; 30480; 9th November.

## Complete Specifications filed after Provisionals.

LIST of complete specifications filed after provisional specifications from the 27th October to the 9th November, 1911, inclusive:—

- No. 29069.—A. Y. Ross, operating pawls of crank and lever-jack.  
 No. 29090.—J. Greenslade, threshing-machine.  
 No. 29104.—W. Wallace and W. Palmer, rabbit-trap.  
 No. 29134.—M. O. Kreissig, show-case.  
 No. 29156.—R. P. Hill, water-pipe cleaner.  
 No. 29157.—United Shoe Machinery Company, shoe- and heel-finishing shaft. (H. W. Winter.)  
 No. 29396.—W. Nicholas, hydraulic ram.  
 No. 29677.—J. J. Charley, vehicle.  
 No. 29959.—M. Moloney, fire-alarm.

## Notice of Acceptance of Complete Specifications.

Patent Office,

Wellington, 15th November, 1911.

COMPLETE specifications relating to the undermentioned applications for Letters Patent have been accepted, and are open to public inspection at this office. Any person may, at any time within two months from the date of this *Gazette*, give me notice in writing of opposition to the grant of any such patent. Such notice must set forth the particular grounds of objection, and be in duplicate. A fee of 10s. is payable thereon.

The copies of claims and extracts from the specifications and drawings are merely intended to give some further indication of the invention than is disclosed in the title, and the complete specifications and drawings should be referred to for a description of the invention.

No. 28385.—20th October, 1909.†—JOHN DOWNHAM, of Barnbrook Iron Works, Bury, Lancaster, England, Engineer. Improvements in decorticating machinery for the extraction of fibres from the leaves of fibre-bearing plants.

*Claims.*—(1.) In a decorticating-machine of the type indicated, the arrangement, use, and application of the special shoe with a raised diagonal stripping-surface upon which the leaf is stripped by the blades of a rotating stripping-drum, substantially as set forth. (2.) The combination of parts arranged and operating substantially in the manner and for the purposes described with reference to the drawings.

(Specification, 4s. 3d.)

No. 28694.—7th November, 1910.—JAMES CHARLES PARKE KIRKWOOD, of 88 Willis Street, Wellington, New Zealand, Engineer. Automatic means or method of controlling or regulating the temperature of electrical heating and cooking apparatus.\*

*Extract from Specification.*—Although means by which this object is carried into effect may vary considerably in detail and construction, the principle thereof will remain substantially the same, which is that of utilizing the expansive and contractive properties due to heating and cooling of suitable metals or materials to effect the automatic breaking and making of an electrical circuit which contains the heating-element. The expanding or contracting metal being either a part of the heating apparatus or a special part attached thereto, the expansion and contraction of said metal being caused by the increase and decrease of the temperature of the apparatus itself.

(Specification, 7s.)

[NOTE.—The above extract from the specification is inserted in place of the claims.]

No. 28752.—18th November, 1910.—WILLIAM EDWARD HUNTER, of Maungakarama, Whangarei, New Zealand, Farmer. An improved wire-strainer.\*

*Extract from Specification.*—This invention relates to that class of appliance for straining fencing-wire in which a drum is mounted to rotate in bearings, and is provided with a ratchet-wheel adapted to be engaged by a pawl on a lever, and thereby to be rotated with the drum in order to coil the wire end on the drum and strain it to the required amount. The invention has been designed in order to provide a construction of bearing-frame for the drum by means of which the appliance may be readily suspended on a fencing-post, and removed therefrom after the wire has been strained and secured, and also to provide means whereby the usual detent-pawl for preventing any reverse movement of the drum,

when straining, may be held out of contact therewith in order to permit of the wire being uncoiled from the drum when required. The invention is also adapted for use in straining and joining together the ends of two wires, and, when used for this purpose, is employed in conjunction with means whereby the strainer appliance may be suspended upon the wires.

(Specification, 5s. 6d.)

[NOTE.—The above extract from the specification is inserted in place of the claims.]

No. 28798.—26th November, 1910.—ALFRED LAUNCELOT JAMES TAIT, of 20 Anderson's Bay Road, Dunedin, New Zealand, Inventor. Improvements in wire-grip fastener for clothes or suitable goods on lines, &c.\*

*Claim.*—(1.) In improvements in wire-grip fasteners for clothes or suitable goods on lines, &c., a wire link with loops, coils, as required, or part of link having a base composed of wire loop or loops made to receive a line and the end or ends of wire to pass over the line down to one side of clothes-line, terminating in a loop or coil pressing over line or side of line, while the link is made to go down to other side of line as illustrated on the drawing, thereby completing pressing on both sides of lines as in Figs. 1, 2, and 3.

(Specification, 2s. 3d.)

[NOTE.—Here follow two other claims.]

No. 28799.—26th November, 1910.—ALFRED LAUNCELOT JAMES TAIT, of 20 Anderson's Bay Road, Dunedin, New Zealand, Inventor. A rotary engine.\*

*Claim.*—(1.) In a rotary engine, reversible when required, a cavity forming piston-wheel C having a shaft at E, and two ends of drum with flanges on each side of wheel C, combined with piston-rings in grooves of said flanges for bearing against rim N of cylinder-case A, and combined with cylinder-case A and with cavities C3 and with block-bars C1, and with free blocks and with caps and with sealing-bars combined in bar C1, and with buffer-spring and with rod C5, and cover C4, and with means to maintain a suitable pressure of bar C1 against rim of drum of piston-wheel C and sides of flanges marked D, and with ports H2 and H3, and with transmission-pipes, and with check-valves R3, R4, and P3, and R, the latter check inward supply, and with controlling-valves P and R, and with entrance-ports P3 and K, and exhaust and ignition-supply valves operated by cams engaging end of valve-rods, buffered by spring resting against the brackets SS, and with carburettors, and with means of ignition and compression by exhaust, and means for supplying benzine to the benzine type of engine, as described and explained, and illustrated on the drawing.

(Specification, 6s. 6d.)

[NOTE.—Here follows one other claim.]

No. 28810.—1st December, 1910.—JOHN HOUSE, of the Forestry Department, Public Offices, Spring Street, Melbourne, Victoria, Australia, Joiner. Improvements relating to the seasoning of timber.\*

*Claims.*—(1.) In improvements relating to the seasoning of timber, a chamber having doors thereto, rails within said chamber, outlet-shafts leading from said chamber, louvres at the tops of said shafts, slide-doors at the bottom of said shafts, manholes and air-inlets to said chamber, a drop-door and deflector within said chamber and over each said manhole and air-inlet. (2.) In improvements relating to the seasoning of timber, a chamber, manholes and air-inlets to said chamber, removable louvres to each manhole and air-inlet, a drop-door and downward deflector within said chamber and covering each manhole and air-inlet, a grating at the bottom of each drop-door and deflector.

(Specification, 7s. 3d.)

[NOTE.—Here follow six other claims.]

No. 28823.—5th December, 1910.—CHARLES WILLIAM MARTIN, of Wellington, New Zealand, Plumber and Electrician. Improved means for the electric heating of ovens and other appliances.

*Extract from Specification.*—The invention consists principally in the combination with the appliance to be heated of a chamber in which the lamps are mounted, and which chamber is so constructed that the heat given off by the lamps therein may be concentrated and led into or through the appliance to be heated. This chamber is also so constructed that provision is made whereby the sockets of the lamps are kept cooled so that they shall not be damaged or affected by the heat of the chamber. The invention also embodies the employment of wire insulated in a particular and special manner for conveying the current to the lamps, such wires being specially insulated to protect them from the heat given off from the heating-chamber.

(Specification, 5s. 3d.)

[NOTE.—The above extract from the specification is inserted in place of the claims.]

No. 28880. — 15th December, 1910. — GEORGE WILSON FOTHERGILL, of Upper Hutt, Wellington, New Zealand, Mill-manager, and WILLIAM HENRY ROGERS, c/o George Fothergill, Upper Hutt aforesaid, Blacksmith. An improved circular-saw guard.\*

*Extract from Specification.*—A base plate secured to the saw-bench frame and having a sliding plate secured thereon to which the lower end of the guard-plate is hinged. This slide-plate is made capable of movement either across or along the base plate, and may be locked in any position. The upper end of the guard is continued up at a tangent, and is held within a clamp secured to the lower end of a stay-rod extending upwards and fastened to a suitable fixture above. This clamp is made of such a nature that the guard may be moved lengthwise through it so as to position it in relation to distance from the saw-edge, or sideways to adjust it in relation to the saw-blade's surface.

(Specification, 4s. 6d.)

[NOTE.—The above extract from the specification is inserted in place of the claims.]

No. 28916. — 21st December, 1910. — FREDERICK HUDSON, of Horace Street, Victoria, Australia, Builder and Contractor. Improvements in table-top and other connecting-means.\*

*Claim.*—(1.) The combination with rails at right angles to one another of brackets having bases as described, extending each at right angles to its rail, and each with an elongated aperture parallel to the aperture in the other base, the bases being fastened (as by screws) through the said apertures to a shrinkable member (as a table-top). (Specification, 6s.)

[NOTE.—Here follow four other claims.]

No. 28927. — 24th December, 1910. — SAMUEL DECIMUS CURRIE, of Te Aroha, New Zealand, Farmer. Improvements in milking-machine teat-cups.\*

*Claim.*—A lining for the teat-cups of milking-machines characterized by being formed of corrugated form in cross-section and with the corrugations extending up the lining to above the level of the teat-point, substantially as and for the purposes specified.

(Specification, 2s. 3d.)

No. 29156. — 20th February, 1911. — RICHARD PARKER HILL, of 63 Queen Street, Auckland, New Zealand, Land Agent. An improved method for cleaning water-pipes.\*

*Extract from Specification.*—A scraper having spring-pressed blades is mounted on the end of a rod and projected into the water-main, the rod being adapted to be rotated and projected further into the main as desired by mechanism described.

(Specification, 4s. 9d.)

[NOTE.—The above extract from the specification is inserted in place of the claims.]

No. 29244. — 11th March, 1911. — MICHAEL EARL, of Otaio, Canterbury, New Zealand, Farm Labourer. Improved means for securing plough-skeiths to the plough-beams.

*Extract from Specification.*—The present invention consists in the use of a plate that is made a fixture upon the beam and extends down it outside face. The plate is formed with a raised central portion on its outside face, and the skeith-shank is arranged to extend up and rest against the raised portion so that it may rock thereon independently of any movement by the plate. Combined with this plate is a clamp of special form, by means of which the skeith-shank is held firmly in position against the plate and the plate held tightly against the beam. When the clamp is slackened the skeith-shank may be tilted in either direction, and then held firmly again in its new position by tightening up the clamp.

(Specification, 4s.)

[NOTE.—The above extract from the specification is inserted in place of the claims.]

No. 29574. — 17th May, 1911. — ALBERT EDWARD YOUNG, of Christchurch, New Zealand, Engineer. Means for folding and wrapping newspapers and the like ready for despatch.\*

*Claim.*—(1.) In a machine for the purpose indicated, the method of folding the newspaper and wrapper preparatory to gumming and sealing, consisting of arranging the newspaper upon edge facing a pair of folding rollers, passing a length of paper to form the wrapper between the face of such newspaper and the rollers, a knife adapted to pass the newspaper and wrapper between said rollers so as to fold such newspaper upon itself for about a third of its height so that the newspaper will lie with its short folded side uppermost within the wrapper and with the ends of such wrapper extending beyond the upper and lower edge of such newspaper, a second knife adapted to descend upon the projecting upper edge of the wrapper and the newspaper and pass such newspaper and wrapper between a second pair of folding-rollers in such a manner as to fold the remaining third upon such

newspaper again, while at the same time placing the portion of the wrapper which was uppermost within the last fold.

(Specification, 13s.)

[NOTE.—Here follow two other claims.]

No. 29723. — 14th June, 1911. — SAMUEL LEVY, of 13 King Street, Newtown, Sydney, New South Wales, Australia, Boot-manufacturer. Improved boot or shoe.\*

*Extract from Specification.*—In manufacturing my improved boot, the material is first cut or stamped out substantially as shown in Fig. 1, the sides forming the upper and the front and rear (or toe and heel) of the central portion are then turned upwards and the adjacent edges stitched or closed as shown in Figs. 2, 3, and 4, the strengthening-piece (12) and tongue (13) are then secured in position, and the eyelet holes (14) stamped out to form the completed boot. A strengthening-strip may be stitched on at 15.

(Specification, 2s. 6d.)

[NOTE.—The above extract from the specification is inserted in place of the claims.]

No. 29791. — 29th June, 1911. — ARTHUR BROWNING MASTERS, of Christchurch, New Zealand, Mercer. Means for use in the collection of car fares, and for indicating the car-seats occupied and the fares paid.\*

*Claims.*—(1.) In means for the collection of fares in public conveyances, the combination with the seats, each one of which is adapted to actuate an electric indicator when sat upon, of a slot upon each seat adapted to receive a metallic fare or token, and provided with contact-points upon which the fare or token is held, and an indicator for each seat arranged in electric circuit with the contact-points in the slot, substantially as specified. (2.) In means for the collection of fares in public conveyances, the combination with the seats, each one of which is adapted to actuate an electric indicator when sat upon, of a slot upon each seat adapted to receive a metallic fare or token, and provided with contact-points upon which the fare or token is held, an indicator for each seat arranged in electric circuit with the contact-points in the corresponding slot, means for releasing the fares or tokens from each slot and (or) from all of the slots, and means for resetting the whole of the indicators, substantially as specified. (3.) In the means for the collection of fares in public conveyances described, the combination with the seats, each one of which is adapted to actuate an electric indicator, when sat upon, of a slot upon each seat adapted to receive a metallic fare or token, and provided with contact-points upon which the fare or token is held, an indicator for each seat arranged in electric circuit with the contact-points in the corresponding slots, and a switch arranged in electric circuit with the whole of the indicators, and adapted to close circuits through them, substantially as specified.

(Specification, 10s. 6d.)

[NOTE.—Here follow five other claims.]

No. 30061. — 18th August, 1911. — JOHN COUTTS, of 3 Dowling Street, Dunedin, New Zealand, Engineer. Improved hose-coupling.

*Claim.*—(1.) In improved couplings of the kind described, a flexible ring having a flange (14), a groove (16), and a rim (17), adapted to form a watertight joint between two parts of a hose-coupling.

(Specification, 1s. 6d.)

[NOTE.—Here follows one other claim.]

No. 30103. — 24th August, 1911. — HARRY JAMES PALIETT, of 547 George Street, Dunedin, New Zealand, Manager, Boot-factory. Improved detachable knives and bosses for skiving-machines.

*Extract from Specification.*—I modify the boss by forming a hollow groove to allow the knife when worn to go further over the feed-roller than is possible at present, thus obtaining more wear from each blade.

(Specification, 3s.)

[NOTE.—The above extract from the specification is inserted in place of the claims.]

No. 30137. — 31st August, 1911. — VIBROCEL COMPANY, LIMITED, a company organized and existing under the laws of the United Kingdom of Great Britain, carrying on business as Contractors at Eldon Street House, Eldon Street, London, England (assignees of Francis Gascoigne Lynde, of "Woodside," London Road, Knebworth, Hertfordshire, England, Civil Engineer, and Everard Richard Calthrop, of Eldon Street House aforesaid, Civil Engineer). A new or improved means or the construction of concrete sea-walls, piers, pontoons, floating stages, foundations, and other structures.

*Extract from Specification.*—In its broadest aspect our invention contemplates a structure for the purposes described composed of vertical hexagonal cells of reinforced vibrated concrete, the whole of the component parts being incorporated and interknitted to form a section or unit.

(Specification, 12s. 6d.)

[NOTE.—The above extract from the specification is inserted in place of the claims.]

No. 30147.—1st September, 1911.—ANDERS PONTEN, of 1537 Alcatraz Avenue, Berkeley, Alameda, California, United States of America. Centrifugal sluicing-apparatus.

*Claim.*—(1.) In a centrifugal sluicing-machine, a circulator composed of a plurality of independent and separable conical hollow sections, the lower edge of each abutting section forming an inwardly projected circumferential riffler or ridge relative to its adjacent section, and means for imparting rotation to said circulator. (Specification, 9s. 3d.)

[NOTE.—Here follow six other claims.]

No. 30154.—4th September, 1911.—HARRY GREIG, of Foxton, New Zealand, Flax-miller. Improvements in flax-strippers.

*Extract from Specification.*—In carrying out the invention each of the chairs for carrying the beater-bar is formed with a recess in it against which the front portion of the bar will fit, and the shoe for holding the bar in position is fitted against the back of the bar and is kept in place by means of a tension-screw passing forwardly from the back of the chair. The guide-bearing for the drum-spindle is situated behind the chair-back and is adjusted in position by means of an adjusting-bolt extending from its back and passing through a lug upon the stripper-frame. The nuts on this bolt engage with this lug and so hold the bearing in position. The bearing is provided with bushes for the drum-spindle bored slightly eccentrically and positioned so as to permit of the spindle springing back from the beater-bar, but to prevent it springing forward beyond the normal. (Specification, 3s. 9d.)

[NOTE.—The above extract from the specification is inserted in place of the claims.]

No. 30155.—4th September, 1911.—JOHN CHARLES FALKINDER, of Takapau, Hawke's Bay, New Zealand, Sheep-farmer. Improved non-refillable bottle.

*Claim.*—(1.) For the purpose indicated, a valve-seat within the neck of the bottle, a disc valve adapted to close down upon the same, a washer having a centrally located hole, and projections which prevent the disc from closing said hole, substantially as specified, and illustrated in the drawing. (Specification, 1s. 9d.)

[NOTE.—Here follow three other claims.]

No. 30160.—6th September, 1911.—MAX GOEBLER, P.O. Box 37, Cedar Cottage, Vancouver, British Columbia, Canada, Civil Engineer. Portable power-operated saws.

*Claim.*—(1.) In a portable saw having a supporting-frame to which a saw-carrying slideway is pivotally mounted, means for securing the supporting-frame to a tree or log, said means comprising a flexible connection secured at one end to the supporting-frame and at the other end to an endwise movable hook on the same frame, and means for endwise moving the hook. (Specification, 5s. 6d.)

[NOTE.—Here follow two other claims.]

No. 30163.—6th September, 1911.—JAMES CHARLES PARKE KIRKWOOD, of 88 Willis Street, Wellington, New Zealand, Electrical Engineer. Improvements in electrical cooking-apparatus.

*Extract from Specification.*—According hereto, I construct an oven having an inner casing and an outer casing, the framework of which is built up of angles, or a frame may be provided for casings in one casting, sides being fitted thereto to complete the casings. The space between the inner and outer casing is either a still air-space or may be provided with tight hollow chambers, the said chambers being either exhausted or not exhausted of air. An airtight chamber may also be provided at the base of the oven; heating-elements are arranged upon this airtight chamber, while a removable airtight chamber is adapted to be placed within the oven upon brackets for the purpose of regulating the size of the compartment in which the cooking is to take place. The heating-elements are provided with terminals adapted to be passed into terminal sockets fixed to the side of the inner casing in order that the said heating-element may be taken out separately for repairs. (Specification, 5s.)

[NOTE.—The above extract from the specification is inserted in place of the claims.]

No. 30166.—6th September, 1911.—ARTHUR ROBERT PONDER, of 94 Rugby Street, Papanui, Christchurch, New Zealand, Commercial Traveller. Improved collapsible forcing-frame.

*Claim.*—(1.) A collapsible forcing-frame comprised of four independent glazed frames, and a glazed top, with means for retaining the parts when assembled, substantially as specified, and illustrated in the drawings. (Specification, 2s. 3d.)

[NOTE.—Here follow three other claims.]

No. 30168.—7th September, 1911.—ARTHUR HENSLEY SMITH, of Grosvenor House, Grosvenor Street, Sydney, New South Wales, Australia, Merchant (nominee of the Domestic Vacuum Cleaner Company, of Worcester, Massachusetts, United States of America, a corporation of Massachusetts, assignees of Frank Julius Quist and Malcolm Blanch, both of Worcester, Massachusetts, United States of America). Improvements in vacuum sweepers.

*Claim.*—(1.) A pneumatic cleaner comprising a casing open at its front end and having apertures, a screen guarding said apertures, a dust-receptacle in said casing detachably connected therewith, a nozzle-head detachably connected with said casing and covering the front end thereof, said nozzle-head being provided with an opening therethrough communicating with said dust-receptacle, a suction-creating device connected with said casing, sustaining-wheels connected with said casing and operatively connected with and automatically operating said suction device by their backward and forward travel over any surface, and means connected with the said casing for adjusting the elevation of the front end thereof. (Specification, 5s. 6d.)

[NOTE.—Here follow two other claims.]

No. 30169.—5th September, 1911.—WILHELM BARTHOLOMÄUS DIDRICK PONNINGHAUS, of 26 Nottingham Street, Prahran, Victoria, Australia, Machinery-importer. Improvements in and connected with floats for controlling the flow of liquids.

*Claim.*—(1.) In improvements in and connected with floats for controlling the flow of liquids, a float the interior of which through a pipe or lever communicates with the atmosphere. (Specification, 6s.)

[NOTE.—Here follow four other claims.]

No. 30182.—7th September, 1911.—PHILLIP ARTHUR GROSSER, of Magnet, Tasmania, Australia, Contractor. Improvements in and connected with the cut-off in chutes.

*Extract from Specification.*—In my invention I use an open chute, and I arrange and operate the cut-off door or knife vertically so that should any lumps of ore or other material be in the way of the knife as it is raised it will be possible to avoid such obstructions by partly lifting and partly negotiating the same. To assist the operation of the invention I arrange a curtain or screen just above the vertically operating knife or door, by means of which the bulk flow of material may be regulated and kept of such a depth that the door, when pushed up, can force its way through the mass. Means are also provided for operating the door and for mounting the chute. (Specification, 2s. 9d.)

[NOTE.—The above extract from the specification is inserted in place of the claims.]

No. 30184.—11th September, 1911.—GEORGE CLAYDON, of Radley, Woolston, Christchurch, New Zealand, and THOMAS MAUDE, of 113 Hereford Street, Christchurch aforesaid, Engineer and Solicitor respectively. Improvements in machines for stripping flax.

*Extract from Specification.*—According to my present invention, the green vegetable matter is planed, shaved, scraped, or stripped from the fibre by a drum turned truly and having feather-edged strips of metal or other suitable material bolted or otherwise attached diagonally around the drum in a right- and left-hand manner. The planing, shaving, scraping, or stripping blades are attached to the strips by bolts or the like. Between the blades blocks of metal are fixed to the drum, so that when drums so provided are revolved together, then the blades on one drum plane, shave, scrape, or strip the flax upon the corresponding block of the opposing drum, or the blades can be so arranged that the green vegetable can be planed, shaved, scraped, or stripped between the edges of each set of blades. Improvements are also provided in tension apparatus for the rollers and in the feeding-apparatus of a stripper. (Specification, 3s. 6d.)

[NOTE.—The above extract from the specification is inserted in place of the claims.]

No. 30194.—30th September, 1910.†—MORITZ KAHN, of Caxton House, Westminster, London, England, Civil Engineer. Improved shoe for piles made of concrete or other plastic material.

*Extract from Specification.*—My invention consists in the combination with a tubular pile of a pointed shoe detachably attached thereto in such a way as to form a part of the tubular pile during driving, and subsequently be detached and drawn up through the tube, leaving an unrestricted passage through the preparatory pile for the deposit of the concrete therein and the ultimate withdrawal of the tubular pile, leaving the concrete pile in the ground. (Specification, 5s. 6d.)

[NOTE.—The above extract from the specification is inserted in place of the claims.]



No. 30204.—13th September, 1911.—MICHAEL FREEMAN LOUNDA, GEORGE FREEMAN LOUNDA, and WILLIAM FREEMAN LOUNDA, all of 62 Sussex Street, Sydney, New South Wales, Australia, Shop-fitters. Improvements in movable shelf-brackets.

*Extracts from Specification.*—According to our invention, the bracket consists of a filleted plate, which may be made with a flanged overhanging portion to facilitate attachment thereto of a shelf. . . . The rear upper part or heel of the bracket is bent and hooked back upon itself to form a grip slidable on a rectangular pillar or standard. The lower part of the bracket forming the toe thereof is similarly bent around so as to form a sliding grip on either side of said pillar or standard, the toe portion being brought to an edge engageable with any one of a number of V notches cut in the front edge of the pillar or standard before mentioned. (Specification, 3s. 3d.)

[NOTE.—The above extracts from the specification are inserted in place of the claims.]

No. 30206.—13th September, 1911.—CHARLES ARTHUR GREEN, of "Chatsworth," Juliett Street, Marrickville, near Sydney, New South Wales, Australia, Traveller. Improvements in overhead electrical trolley-line ears.

*Extract from Specification.*—The essential feature of my invention is the combination with a permanent carrier of a light envelope forming a clip for round wire, said envelope being clamped in and supported by the carrier.

(Specification, 4s. 3d.)

[NOTE.—The above extract from the specification is inserted in place of the claims.]

No. 30209.—13th September, 1911.—JEFFREY DENNIS, of Fore Street, Canterbury, Sydney, New South Wales, Australia, Tanner, and WILLIAM LESLIE FIDLER, of "Ravenswood," Gordon, Sydney aforesaid, Gentleman. Fluid-enclosed vacuum chambers.

*Claims.*—(1) A fluid-enclosed vacuum vessel, chamber, or container, composed of concrete and metal reinforcement, a bottle-neck attachment secured thereto having a channelled seating-ring thereon, and a flexible insertion in the channelled seating-ring to seat a removable access-door. (2) In a fluid-enclosed vacuum vessel, chamber, or container, the combination, with a bottle-neck attachment forming part of such vessel, of a removable access-door, and the means for securing said door, consisting of supporting-hangers having a bridge-piece suspended thereon and a clamping-screw to seat and secure said access-door. (Specification, 7s. 9d.)

[NOTE.—Here follow six other claims.]

No. 30210.—12th September, 1911.—THE PEAT COAL INVESTMENT COMPANY, LIMITED, of 34 Nicholas Lane, Lombard Street, London E.C., England, Manufacturers (assignees of Thomas Rigby, Station Hotel, Dumfries, Scotland). Improved method and apparatus for gathering and transporting peat.

*Claims.*—(1) A method of gathering or transporting peat hydraulically, consisting in cutting the peat from the bog or other source, then disintegrating or pulping the same to a more or less uniform condition, and then conveying the watery disintegrated peat to the desired spot, as by pumping through a pipe-line or other duct, substantially as described. (2) Apparatus for carrying out the method of claim 1, consisting of a peat-excavator supplying a disintegrating-device and a pipe-line through which the substance leaving the disintegrator is caused to pass to the desired spot by a suitable pumping-device, substantially as described. (Specification, 6s. 3d.)

[NOTE.—Here follow three other claims.]

No. 30211.—13th September, 1911.—CAMPBELL ERNEST McCAY, of 7 Kalimna Street, Essendon, Victoria, Australia, Accountant. Means for raising, lowering, or conveying cargo or other weighty material from one level or position to another.

*Claim.*—(1) In raising, lowering, or conveying cargo or other weighty material from one level or position to another, means by which a synchronous transfer of brake-action is effected from one cable or rope to the other in such a manner that a carrier may be moved along the suspension cable or rope whilst the weight-supporting cable or rope is gripped by its respective brake, and alternately that when the suspension cable or rope is gripped by its respective brake the weight-supporting cable or rope is freed so that said weight may be lifted or lowered, substantially as and for the purposes set forth. (Specification, 8s. 6d.)

[NOTE.—Here follow five other claims.]

No. 30213.—14th September, 1911.—HENRY SELBY HELE-SHAW, LL.D., Fellow of the Royal Society, and FRANCIS LEIGH MARTINEAU, Fellow of the Institution of Mechanical Engineers, both of No. 64 Victoria Street, London S.W., England. Improvements in hydraulic transmission apparatus.

*Claims.*—(1) In hydraulic transmission apparatus for power-driven vehicles, the combination of a continuously driven variable-stroke pump carried by the vehicle and a motor or motors in a closed liquid circuit, the motors essentially forming the bodies of vehicle-wheels. (2) The hydraulic-motor wheel for use in combination with a variable-stroke pump, said wheels comprising the combination of an axle constructed to form a valve radiating cylinders rotatable relative to the axle-valve and occupying position usually occupied by the wheel-spokes, pistons associated with the cylinders, devices carried by the pistons and co-operating with fixed cams or eccentrics, and a felloe or enclosing rim surrounding the cylinders, substantially as specified. (Specification, 8s. 9d.)

[NOTE.—Here follow nine other claims.]

No. 30222.—14th September, 1911.—HARRY HUDSON SHAW, of Hamilton, Auckland, New Zealand, Farmer. An improved water-power developer.\*

*Extract from Specification.*—The wheel is constructed and mounted in the usual way, provision being made for shutting the water off from it by means of a hinged door in the floor of the floating platform which forms the bottom of the race or chute. Attached to the forward end of the race or chute is a funnel-shaped fluming for the purpose of catching the running water and concentrating it on to the paddles of the wheel. (Specification, 4s. 9d.)

[NOTE.—The above extract from the specification is inserted in place of the claims.]

No. 30226.—19th September, 1911.—HARRY WOOD DOWNING, of Gloucester Street, Christchurch, New Zealand, Saddler. Improvements in riding and harness saddles.

*Extract from Specification.*—According hereto, a saddle is made of green hide moulded to shape upon a block, and stretched in superposed thicknesses over a tree made of compressed fibre, leather, or thin wood. The head of the tree, made of a thin steel plate or thin wood or compressed fibre stiffened with a metal plate, is connected to the tree by the green hide, and in the case of heavier saddles by plates extending along the sides of the tree. "D" or other fastenings for the girth are dispensed with, the girth-straps being merely stitched to the green hide and the leather or compressed-fibre tree. (Specification, 4s.)

[NOTE.—The above extract from the specification is inserted in place of the claims.]

No. 30232.—20th September, 1911.—WALTER TAINE, of Crawford Street, Dunedin, New Zealand, Manager, Taines' Chemical Stores Company (assignee of James Sinclair, of Barrack Street, Sydney, Australia). Improvements in containers for boot-blackening and the like.

*Extract from Specification.*—According hereto, a lever pivoted upon the side of the container has a thumb-piece at the end of its long arm and a right-angled projection at its short end. A recess allows the said projection to pass below the rim of the lid. (Specification, 2s. 3d.)

[NOTE.—The above extract from the specification is inserted in place of the claims.]

No. 30246.—22nd September, 1911.—WILLIAM GEORGE JAMES, of Stratford, New Zealand. An improved cigarette-holder.

*Extract from Specification.*—The invention consists in the combination with a mouthpiece of suitable material made of uniform diameter throughout its length and adapted to receive the cigarette, of a grip attached to and extending beyond the outer end of the mouthpiece and shaped to encircle and hold the cigarette, and thus to keep it in position in the mouthpiece. This grip is preferably formed of two semicircular frames one of which is fixed to the mouthpiece and forms a rest in which the cigarette will lie, and the other one of which is hinged along one of its edges to the corresponding edge of the first half. It is thus capable of turning in over the top part of the cigarette, and thereby to hold it firmly between itself and the lower half. (Specification, 2s. 9d.)

[NOTE.—The above extract from the specification is inserted in place of the claims.]

No. 30249.—23rd September, 1911.—ERNEST WILLIAM HURSTHOUSE, Wellington, New Zealand, Mechanical Engineer. Improvements in vacuum cleaning-machines.

*Extract from Specification.*—According hereto, a dirt-receptacle is fitted with a filter in the form of a diaphragm comprising sand, gravel, quartz, polarite oxidium, or a similar

finely divided material, held in position between layers of wire gauze supported by smut-wire mesh, grids, or the like. A disinfectant and antiseptic liquid or powder falls from a vessel placed above the inlet to the receptacle, and mixes with the dirt-laden air as it enters the receptacle. In my apparatus water is not necessary for the purpose of filtering, but for the purpose of distributing the disinfectant and antiseptic liquid or powder water in the receptacle is considered the best medium. (Specification, 5s. 3d.)

[NOTE.—The above extract from the specification is inserted in place of the claims.]

Copies of drawings may be obtained at the uniform price of 1s. each. In exceptional cases this price may be increased at the discretion of the Office.

An asterisk (\*) denotes the complete specification of an invention for which a provisional specification has been already lodged. A dagger (†) denotes a prior date under the International and Intercolonial Arrangements.

NOTE.—The cost of copying the specification has been inserted after the notice of each application. An order for a copy or copies should be accompanied by a post-office order or postal note for the cost of copying.

The date of acceptance of each application is given after the number.

Extracts from the drawings accompanying the foregoing complete specifications appear at the end of this Gazette.

J. C. LEWIS,  
Registrar.

#### Provisional Specifications accepted.

Patent Office.

Wellington, 9th November, 1911.

APPLICATIONS for Letters Patent, with provisional specifications, have been accepted as under:—

- No. 29723.—S. Levy, boot or shoe.  
No. 30045.—J. W. H. Fredric, J. H. Butcher, and P. W. Willson, spark-arrester.  
No. 30060.—R. S. Rutherford, vacuum cleaner.  
No. 30065.—W. Jermyn, securing lids on cans.  
No. 30114.—R. Brennan, nutmeg-grater.  
No. 30134.—C. Britsow, sealing correspondence.  
No. 30139.—A. Horton, flooring, &c., cramp.  
No. 30146.—H. Butcher, tumbler mud-camp lifting-gear.  
No. 30149.—J. O'Neill, saw-bench return-feed.  
No. 30177.—T. and J. Diprose, hygienic belt.  
No. 30178.—J. and A. Fear, closet-flush.  
No. 30188.—F. J. Brown, spanner.  
No. 30190.—F. S. Palmer, bread-renewer.  
No. 30193.—A. F. Bush, concrete-mould clamp.  
No. 30198.—G. E. D. Seale, drawing boring-pipe casing from ground.  
No. 30216.—J. Henry, road-scoop.  
No. 30218.—J. E. Hayman, reaper-and-binder wind-screen.  
No. 30235.—A. H. Atkinson, gas-meter.  
No. 30237.—W. Scott, friction-clutch.  
No. 30250.—P. Tait, horse-shoeing hammer.  
No. 30251.—B. Speight, saw.  
No. 30261.—W. W. Ewbank, obtaining crude oil from peat, &c.  
No. 30262.—J. Oliver and A. C. Anderson, sausage-machine.  
No. 30265.—T. Goodall, guard-rail for car.  
No. 30267.—G. R. Fulyerd, egg-substitute.  
No. 30268.—A. H. Wright, advertising-mechanism.  
No. 30269.—W. G. Wright, P. H. Watkins, and S. A. Webber, attaching lamp to vehicle.  
No. 30271.—T. P. Eustege, liquid heater, strainer, &c.  
No. 30273.—K. L. Bromwich, picture-hanging.  
No. 30275.—A. E. Wilcox, envelope and tag.  
No. 30276.—F. W. Grigg, extracting wool-fat.  
No. 30278.—A. Fibbes and J. A. C. Clyma, road-grading, &c., implement.  
No. 30280.—G. V. Beck, book-hanger.  
No. 30281.—D. H. Munn, liniment.  
No. 30283.—T. M. Abbott, phonograph-attachment.  
No. 30284.—J. F. Wilson, speed-mechanism.  
No. 30286.—N. Harvey, electric-lamp holder.  
No. 30291.—A. H. Wright, advertising-mechanism.  
No. 30292.—D. G. S. McKenzie, money-box.  
No. 30293.—A. H. Wright, advertising-mechanism.  
No. 30298.—D. J. Hurley, door, &c., regulator.  
No. 30300.—M. Barratt, railway fish-plate.

- No. 30308.—G. G. Holmes, jun., tobacco-pipe attachment.  
No. 30311.—F. T. F. Evans, harrow.  
No. 30312.—H. Clapham, sen., air-gas production.  
No. 30313.—A. McKinney, G. E. Curtis, O. Curtis, and W. Williams, rabbit packing and freezing.  
No. 30314.—H. Neville and F. S. Norrie, bicycle toe-clip, &c.  
No. 30318.—Ridd Milking Machine Company, Limited, milking-machine pulsator. (T. B. Sutton.)  
No. 30323.—F. G. Baker, hatpin.  
No. 30325.—W. P. Styles, device for holding paint-pots on roofs.  
No. 30327.—E. G. Sander, H. Mander, and E. Apled, upholsterers' needle.  
No. 30333.—United Shoe Machinery Company, shoe-beating machine. (G. S. Covell.)  
No. 30335.—D. Park, hairpin.  
No. 30336.—B. J. Weger, well-boring appliance.  
No. 30339.—D. Theyers, E. P. Hill, and G. G. Poulton, liquid-vessel, &c.  
No. 30344.—B. J. Weger, well drilling plant.  
No. 30350.—A. McDonald and H. Schlaadt, crowbar.  
No. 30356.—A. T. Gauntlett, knife-cleaner.  
No. 30358.—A. M. Butterworth, concrete-mould.  
No. 30360.—C. W. Ziele, boot-polish-tin holder.  
No. 30363.—W. E. Gregory, telegram-form.  
No. 30373.—D. Donald, crowbar, jack, and rammer.  
No. 30391.—W. E. Leeson, aerated-water-fountain cylinder.  
No. 30394.—J. R. Templin, electric-light sign.  
No. 30395.—C. Suttie and M. H. Wynyard, flax-catcher releasing-gear.  
No. 30404.—D. Jones, steam-generator.  
No. 30427.—J. E. Bull, puncture-detector.  
[NOTE.—Provisional specifications cannot be inspected, or their contents made known by this office in any way, until the complete specifications in connection therewith have been accepted.]

#### Letters Patent sealed.

LIST of Letters Patent sealed from the 27th October to the 8th November, 1911, inclusive:—  
Nil.

#### Letters Patent on which Fees have been paid.

[NOTE.—The dates are those of the payments.]

##### SECOND-TERM FEES.

- NO. 23667.—P. R. Hughes, hoisting and stacking wool, &c., bales. 8th November, 1911.  
No. 23668.—W. C. Higinbotham, acetylene-generator. (C. Gerber and E. Michaut—P. G. Aylmer—H. R. R. Lewis.) 31st October, 1911.  
No. 23677.—R. O. Clark, Limited, junction-chamber. (R. M. Smith.) 3rd November, 1911.  
No. 23680.—R. Dunne, mitre-cutter. 2nd November, 1911.  
No. 23717.—E. Clemens Horst Company, hop-picker. (E. C. Horst and J. Ehrhorn.) 8th November, 1911.  
No. 24899.—O. L. Eugster, porcelain-lined siphon-head. 4th November, 1911.

##### THIRD-TERM FEES.

- No. 18818.—E. S. Clark, apparatus for recovering metals, &c., from crushed ores, washdirt, &c. 9th November, 1911.

#### Subsequent Proprietors of Letters Patent registered.

[NOTE.—The name of the former proprietor is given in brackets; the date is that of registration.]

- NO. 27273.—Exclusive license noted on Register to Edward Collie, of Wellington, New Zealand, Cabinet-maker, for three years from 8th October, 1911, on terms and conditions set out in deed. Folding corner wardrobe. (R. May, F. E. May, and A. W. Railton.) 2nd November, 1911.  
No. 27849.—Carlite Gessellschaft, m.b.H., of 3 Roon Strasse, Berlin, Germany. Explosive. (C. Wester.) 2nd November, 1911.  
Nos. 28002 and 28003.—Totalling Mechanisms, Limited, of Norwich Chambers, Hunter Street, Sydney, in the State of New South Wales (a company registered under the provisions of the Acts relating to companies in the State of New South Wales). Apparatus for printing tickets, &c., and for registering and totalling numbers, &c. (G. A. Julius.) 2nd November, 1911.  
No. 28175.—William Boyd, of Queen Street, in the City of Auckland, in the Dominion of New Zealand, Whip-thong Manufacturer. Wire-bound thong. (J. McLaren.) 27th October, 1911.

**Notice of Request to amend Specification.**

Patent Office,  
Wellington, 9th November, 1911.

**R** EQUEST for leave to amend the undermentioned application for Letters Patent has been received and is open to public inspection at this office. Any person may, at any time from one month from the date of this *Gazette*, give me notice in writing of opposition to the amendments. Such notice must set forth the particular grounds of objection, and be in duplicate. A fee of 10s. is payable thereon.

No. 29104.—W. Wallace and W. Palmer, rabbit-trap. (Advertised in Supplement to *New Zealand Gazette*, No. 23, of the 23rd March, 1911.)

The nature of the proposed amendment is as follows:—

To strike out the name of William Palmer from the application and complete specification.

The applicants state: Our reason for making the amendment is that the said William Palmer has ceased to become interested in the invention.

J. C. LEWIS,  
Registrar.

**Request for Correction of Clerical Error in Application for Letters Patent.**

**N** O. 30223.—W. F. Lietz, carburettor. (Advertised in Supplement to *New Zealand Gazette*, No. 88, of the 2nd November, 1911.)

To alter the name from "Lietz" to "Leitz."

**Application for Letters Patent opposed.**

**N** O T I C E of opposition has been filed in the following case:—

No. 29884.—M. Wilbuschewitsch, opposed by J. Crosfield and Sons, Limited.

**Applications for Letters Patent abandoned.**

**L** I S T of applications, with which provisional specifications only have been filed, abandoned (*i.e.* complete specifications not lodged) from the 28th October to the 9th November, 1911, inclusive:—

- No. 28933.—F. and T. Dixon, traction-engine gear wheel.
- No. 28937.—E. Unsworth, concrete-wall construction.
- No. 28951.—W. Andrews and A. W. Beaven, oil-engine and vacuum pump.
- No. 28953.—A. Sorenson, level.
- No. 28960.—H. R. Jenkins, milk-sampler. (P. E. Bryant).
- No. 28962.—E. F. Lutz, directory.

**Applications for Letters Patent void.**

**A** P P L I C A T I O N S for Letters Patent, with which complete specifications have been lodged, void owing to non-acceptance of such complete specifications, from the 27th October to the 9th November, 1911, inclusive:—

- No. 28173.—J. A. F. Glover, cooking-oven.
- No. 28204.—G. F. Ollerenshaw, clothes-peg.
- No. 28209.—W. R. Eade, swingletree-hook.
- No. 28217.—A. McLeod, califont.
- No. 28235.—S. G. Whittall, bath.

**Applications for Letters Patent lapsed.**

**A** P P L I C A T I O N S for Letters Patent lapsed, owing to Letters Patent not being sealed, from the 28th October to the 9th November, 1911, inclusive:—

- No. 27630.—G. H. Knight, parcel and basket strap.
- No. 27637.—A. M. MacLeod, clothes-drier.
- No. 27643.—C. Ingram, brick-kiln.
- No. 27650.—S. A. Heap and G. W. Allan, telephone-transmitter attachment.
- No. 27687.—T. S. Philpott and F. Beagley, reinforced-concrete frame.
- No. 27688.—A. I. Jones, flax-dressing machine.
- No. 27698.—H. W. Davies, bucket-handle.
- No. 27709.—J. Cook and H. Thompson, oven-slide holder and stand.

**Letters Patent void.**

**L** I S T of Letters Patent void through non-payment of renewal fees, and through expiry of term of fourteen years, from the 28th October to the 9th November, 1911, inclusive:—

**THROUGH NON-PAYMENT OF SECOND-TERM FEES.**

- No. 23217.—F. R. Simmonds, flax-washer.
- No. 23225.—P. Bock, support for cartons, &c.
- No. 23231.—G. W. Beldam, machine-packing.
- No. 23233.—J. Gill, rotary engine.
- No. 23234.—E. V. Gandil, milking-machine.
- No. 23235.—A. Stokes, A. Heither, and A. W. Heither, anæsthetic compound.
- No. 23238.—F. H. Webb, nail.
- No. 23241.—H. S. McCully, bird-trap.
- No. 23243.—W. Meharry, travelling emery for flax-stripper.
- No. 23248.—F. A. Fischer, testing heat in wool-bale.
- No. 23256.—J. J. Blockley and J. A. Lissington, ventilator.
- No. 23257.—C. T. Tatum, step-ladder.
- No. 23262.—A. H. Wood, jointing-bracket. (A. H. Wood and H. W. de Baugh.)
- No. 23265.—S. Campbell and J. S. Gribbon, broom or brush handle.
- No. 23271.—J. C. MacMichael, ruler.
- No. 23273.—G. E. Forward and W. J. Bird, apparatus for teaching the use of the rifle.
- No. 23274.—F. Cotton, iron or steel treatment.
- No. 23276.—H. D. P. Huizer, drinking-vessel.
- No. 23280.—E. S. Baldwin and H. H. Rayward, rock-drill chuck. (J. H. and J. M. Holman.)
- No. 23297.—C. A. Smith, J. C. Brown, and A. R. Smith, docking and castrating apparatus. (C. A. Smith, J. C. Brown, A. R. Smith, and A. H. Wills.)

**THROUGH NON-PAYMENT OF THIRD-TERM FEES.**

- No. 18224.—United Shoe Machinery Company, brush. (C. E. Graham.)
- No. 18231.—Leslie Walker Fire Alarm Company, Limited, temperature-alarm. (Leslie Walker Instantaneous Fire Detector and Fire Indicator Company, Limited—C. L. Walker.)
- No. 18237.—G. E. Humphries, window-sash.
- No. 18270.—W. Goodman, commercial reply-card.
- No. 18284.—J. and P. Walker, skylight. (H. Ward.)
- No. 18293.—C. E. Bernays, combustion of fuel.

**THROUGH EXPIRY OF TERM.**

- No. 10071.—Diamond Match Company, Limited, sheet-metal box. (T. L. Carbone.)
- No. 10089.—Imperial Writing Machine Company, Limited, typewriting-machine. (W. P. Kidder.)
- No. 10101.—Wilfley Ore Concentrator Syndicate, Limited, ore-concentrator. (A. R. Wilfley.)

**Design registered.**

**A** D E S I G N has been registered in the following name on the date mentioned:—

- No. 565.—Henry Eli White, of Wellington, N.Z., Structural Engineer. Class 1. 26th October, 1911.

**Designs expired.**

**T** H E copyright in the following designs has expired:—

- No. 307.—A. A. Holdsworth. Class 10.
- No. 308.—A. D. Sloane. Class 1.
- No. 309.—A. B. Crisp. Class 1.
- No. 310.—W. Hinson. Class 1.

**Applications for Trade Marks filed.**

**L** I S T of applications for registration of Trade Marks filed from the 28th October to 9th November, 1911, inclusive:—

- No. 10029.—26th October.—A. H. and A. E. Humphries, Melbourne, Vic. Class 42.
- No. 10030.—27th October.—J. Rattray and Son, Limited, Dunedin, N.Z. Class 42.
- Nos. 10031 and 10032.—27th October.—New Zealand Candle Company, Kaiwarra, N.Z. Class 47.
- No. 10033.—28th October.—A. Tyree and Co., Christchurch, N.Z. Class 38.
- No. 10034.—30th October.—Fitt and Clayton, Auckland, N.Z. Class 47.

No. 10035.—30th October.—A. P. Masters, Wellington, N.Z. Class 2.  
 No. 10036.—2nd November.—D. Tewes, "J. Dirlam and Sons," Sydney, N.S.W. Class 12.  
 No. 10037.—2nd November.—J. Wiseman and Sons, Limited, Auckland, N.Z. Class 50.  
 No. 10038.—3rd November.—Eruptite Explosives Company of New Zealand, Limited, Wellington, N.Z. Class 20.  
 No. 10039.—3rd November.—D. H. Gilmour, Dunedin, N.Z. Class 42.  
 No. 10040.—4th November.—C. Aickin and Son, Auckland, N.Z. Class 42.  
 No. 10041.—6th November.—Eagle Pencil Company, New York, U.S.A., and London, Eng. Class 39.  
 Nos. 10042, 10043, and 10044.—6th November.—Mount Vernon-Woodberry Cotton Duck Company, Baltimore, U.S.A. Class 24.  
 No. 10045.—6th November.—Mount Vernon - Woodberry Cotton Duck Company, Baltimore, U.S.A. Class 50.  
 Nos. 10046 and 10047.—6th November.—W. A. Tyack and Co., Sheffield, Eng. Classes 7 and 12.  
 No. 10048.—6th November.—D. McCrae, Wellington, N.Z. Class 41.  
 No. 10049.—7th November.—A. Boake, Roberts, and Co., Limited, London, Eng. Class 42.  
 No. 10050.—7th November.—Aktiebolaget Pump Separator, Stockholm, Sweden. Class 7.  
 No. 10051.—7th November.—W. Hunt and Sons, The Brades, Limited, Birmingham, Eng. Class 12.  
 No. 10052.—8th November.—T. M. Goodall and Co., Limited, Sydney, N.S.W. Class 47.  
 No. 10053.—9th November.—C. Gray and A. Jobson, Auckland, N.Z. Class 4.  
 No. 10054.—9th November.—Ford Motor Car Company of Canada, Limited, Walkerville, Canada. Class 22.

**Applications for Registration of Trade Marks.**

Patent Office,  
 Wellington, 15th November, 1911.

**A** PPLICATIONS for registration of the following Trade Marks have been received. Notice of opposition to the registration of any of these applications may be lodged at this office within two months of the date of this *Gazette*. Such notice must be in duplicate, and accompanied by a fee of £1.

No. of application : 9349.  
 Date : 1st February, 1911.

**TRADE MARK.**

The words

**THE INVICTA.**

The essential particular of this trade mark is the following—the word "Invicta"; and any right to the exclusive use of the added matter is disclaimed.

No. of application : 9843.  
 Date : 17th August, 1911.

**TRADE MARK.**



The essential particular of this trade mark is the distinctive label.

**NAME.**

**MEREDITH BROS. AND Co.,** of Aratapu, in the Dominion of New Zealand, Cannery.

No. of class : 42.  
 Description of goods : Fish and soup.

B

**NAME.**

**E. M. DICKINSON, LIMITED,** of Murray Works, Rockingham Street, Sheffield, England, Cutlery-manufacturers.

No. of class : 12.  
 Description of goods : Cutlery.

No. of application : 9611.  
 Date : 5th May, 1911.

**TRADE MARK.**



The essential particular of the trade mark is the device; and any right to the exclusive use of the word "Chic" is disclaimed.

**NAME.**

**TOOTAL BROADHURST LEE COMPANY, LIMITED,** of 56 Oxford Street, Manchester, England, Manufacturers and Merchants.

No. of class : 25.  
 Description of goods : Cotton goods not included in Classes 23, 24, or 38.

No. of application : 9764.  
 Date : 11th July, 1911.

**TRADE MARK.**

The word

**WESTFALIA.**

No claim is made to any right to the exclusive use of the word "Westphalia."

**NAME.**

**BEWLEY LIMITED,** of 57 Liverpool Street, Sydney, New South Wales, in the Commonwealth of Australia, Manufacturers' Agents.

No. of class : 6.  
 Description of goods : Cutting, slicing, or dividing machines, and other goods included in this class.

No. of application: 9844.  
Date: 17th August, 1911.

TRADE MARK.



The essential particular of this trade mark is the distinctive device.

NAME.

MEREDITH BROS. AND Co., of Aratapu, in the Dominion of New Zealand, Cannery.

No. of class: 42.  
Description of goods: Fish and soup.

No. of application: 9912.  
Date: 12th September, 1911.

TRADE MARK.

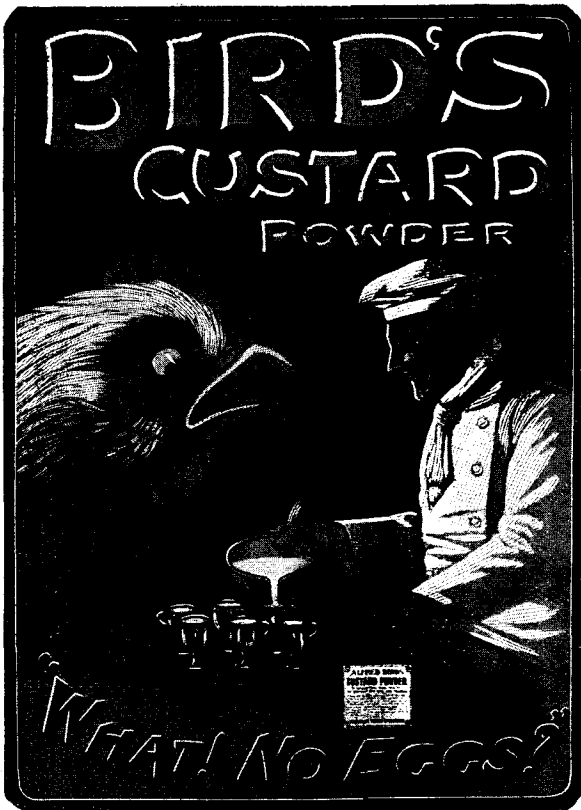

The essential particular of this trade mark is the distinctive label; and any right to the exclusive use of the added matter is disclaimed.

NAME.

ALFRED BIRD AND SONS, LIMITED, of Devonshire Works, Deritend, Birmingham, Warwickshire, England, Manufacturers.

No. of class: 42.  
Description of goods: Custard-powder.

No. of application: 9913.  
Date: 12th September, 1911.

TRADE MARK.



NAME.  
THE WALL PAPER MANUFACTURERS, LIMITED, of Walpamur Branch, Hollins Mills, Darwen, Lancashire, England, Manufacturers.

No. of class: 1.  
Description of goods: Paints of every description, including water-paints, colours, varnishes, and enamels, and also including dry powder.

No. of application: 9930.  
Date: 21st September, 1911.

TRADE MARK.



The essential particular of this trade mark is the combination of devices; and the applicants disclaim any right to the exclusive use of the added matter, except the name "Heathcoat."

NAME.

The persons trading as JOHN HEATHCOAT AND Co., of 13 Ironmonger Lane, London E.C., England, and Tiverton, Devon, England, Silk Net and Lace Manufacturers.

No. of class: 31.  
Description of goods: Silk nets and silk veilings in the piece.

No. of application: 9932.  
Date: 23rd September, 1911.

TRADE MARK.

The word

Ok.

No claim is made to the exclusive use of the letters "O.K."

NAME.

THE ROYAL OAK TIMBER COMPANY, LIMITED, of Auckland, in the Dominion of New Zealand, Timber-merchants.

No. of class: 50.  
Description of goods: Wood joinery and machined wood-ware.

No. of application: 9942.  
Date: 28th September, 1911.

TRADE MARK.

The word

HERCULES.

The essential particular of this trade mark is the word "Hercules."

NAME.

ALLINSON AND Co., of Northampton, England, Boot-manufacturers.

No. of class: 38.  
Description of goods: Boots and shoes of leather.

No. of application: 9948.  
Date: 2nd October, 1911.

TRADE MARK.

"HORSE-SHOE" BRAND.

TRADE



MARK

REGISTERED.

The essential particulars of this trade mark are the words "Horse-shoe" and the device; and any right to the exclusive use of the added matter is disclaimed.

NAME.

THOMAS MACINTYRE AND Co., of Dundas, Glasgow, Scotland, Oil and Colour Merchants.

No. of class: 47.

Description of goods: Oils, illuminating, heating, and lubricating included in this class, but not including benzene.

No. of application: 9965.  
Date: 10th October, 1911.

TRADE MARK.

# TEKKO

The essential particular of the trade mark is the following—the arbitrary word "Tekko."

NAME.

SALUBRA WALL-COVER COMPANY BASLE, a corporation organized under the laws of Switzerland, and located Freiestrasse 107, at Basle, Switzerland.

No. of class: 41.

Description of goods: Paperhangings and other wall-coverings included in this class.

No. of application: 9966.  
Date: 10th October, 1911.

TRADE MARK.

The word

## MATTHO.

The essential particular of the trade mark is the following—the arbitrary word "Mattho."

NAME.

SALUBRA WALL-COVER COMPANY BASLE, a corporation organized under the laws of Switzerland, and located Freiestrasse 107, at Basle, Switzerland.

No. of class: 41.

Description of goods: Paperhangings and other wall-coverings included in this class.

No. of application: 9967.  
Date: 10th October, 1911.

TRADE MARK.

The word

## SALUBRA.

The essential particular of the trade mark is the following—the arbitrary word "Salubra."

NAME.

SALUBRA WALL-COVER COMPANY BASLE, a corporation organized under the laws of Switzerland, and located Freiestrasse 107, at Basle, Switzerland.

No. of class: 41.

Description of goods: Paperhangings and other wall-coverings included in this class.

No. of application: 9968.  
Date: 10th October, 1911.

TRADE MARK.

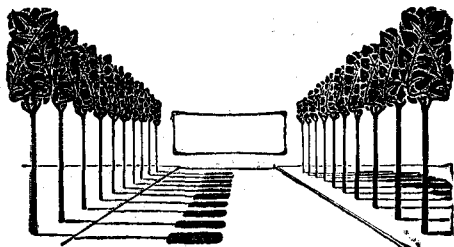

The essential particular of the trade mark is the following—the representation of an avenue of trees.

NAME.

SALUBRA WALL-COVER COMPANY BASLE, a corporation organized under the laws of Switzerland, and located Freiestrasse 107, at Basle, Switzerland.

No. of class: 41.

Description of goods: Paperhangings and other wall-coverings included in this class.

No. of application: 9972.  
Date: 12th October, 1911.

TRADE MARK.



The essential particulars of this trade mark are the distinctive device and the invented word "ASGA"; and any right to the exclusive use of the letters "A," "S," "G," "A," used individually or in the formation of any dissimilar word, is disclaimed.

NAME.

PHILIPS AND PIKE, of National Mutual Insurance Company's Buildings, Customhouse Quay, Wellington, in the Dominion of New Zealand, Merchants.

No. of class: 13.

Description of goods: Lamps and lanterns of all kinds, and parts thereof, whether for gas or for oil, spirits, benzene, or other fluids; furnishings for lamps, burners, reflectors, shades, lamp-galleries, supports for incandescent mantles, supports for reflectors, bells, lamp or lantern guards, cocks and valves, sockets, nipples, unions, ball-and-socket joints, elbows, smoke-bells, counter-weights, pendants, brackets, coronas, candelabra, chandeliers, gas-standards, gas-lighters and fittings, and fittings and parts of stoves or apparatus for cooking or heating purposes—all the said goods being wholly or principally of ordinary metal and included in Class 13.

No. of application: 9973.  
Date: 13th October, 1911.

TRADE MARK.

The words

## GOOD CHEER.

NAME.

BRAY BROS., of Boulcott Chambers, Boulcott Street, Wellington, in the Dominion of New Zealand.

No. of class: 42.

Description of goods: Tea, coffee, and cocoa.

No. of application: 9974.  
Date: 13th October, 1911.

TRADE MARK.

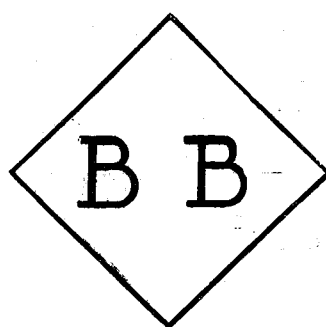

The essential particular of this trade mark is the distinctive label; and any right to the exclusive use of the initials "BB" is disclaimed.

NAME.

BRISCOE AND COMPANY, LIMITED, of Wellington, in the Dominion of New Zealand, Iron-merchants.

No. of class: 5.

Description of goods: Galvanized corrugated iron, plain galvanized-iron plates, black-iron sheets, and iron or steel plates and goods of such description.

No. of application : 9975.  
Date : 13th October 1911.

TRADE MARK.  
BUTTERFLY.

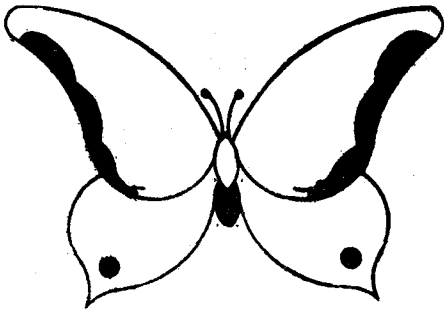

The essential particulars of this trade mark are the word "Butterfly," and the device of a butterfly. The applicants claim that the said trade mark has been used by them and their predecessors in business, Ambury, English, and Co., prior to and continuously since 1893.

NAME.

AMBURY LIMITED, of Karangahape Road, in the City of Auckland, Dominion of New Zealand, Dairy-factory Proprietors.

No. of class : 42.  
Description of goods : Dairy-produce.

No. of application : 10018.  
Date : 19th October, 1911.

TRADE MARK.

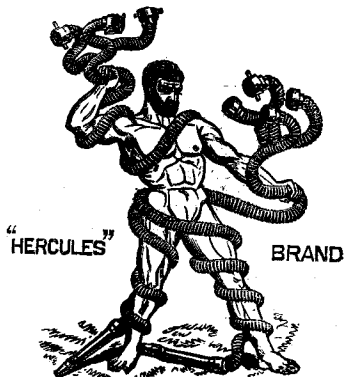

The essential particulars of this trade mark are a pictorial device of a figure representing Hercules and the word "Hercules"; and any right to the exclusive use of the word "Brand" is disclaimed.

NAME.

F. REDDAWAY AND Co., LIMITED, of Cheltenham Street, Pendleton, Manchester, in the County of Lancaster, in England, Manufacturers.

No. of class : 50.  
Description of goods : Hose and packing.

No. of application : 10019.  
Date : 20th October, 1911.

TRADE MARK.

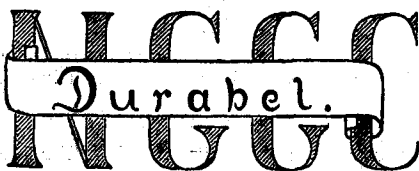

The essential particular of this trade mark is the distinctive label.

NAME.

NORDISK GUMMI AND GUTTAPERCHA COMPANY, of Vester-voldgade, 11 Copenhagen, Denmark, Europe.

No. of class : 35.  
Description of goods : Machine-belted included in this class.

No. of application : 10020.  
Date : 20th October, 1911.

TRADE MARK.



The essential particulars of this trade mark are the general design, an acorn and oak-leaf, and the twisted band of circular shape enclosing the whole; and any right to the exclusive use of the words "Finest Creamery," and the letters "T.V." is disclaimed.

NAME.

THE THAMES VALLEY CO-OPERATIVE DAIRYING COMPANY, LIMITED, of Paeroa, Ohinemuri, in the Dominion of New Zealand.

No. of class : 42.  
Description of goods : Butter.

No. of application : 10033.  
Date : 28th October, 1911.

TRADE MARK.

The word  
**AMULET.**

NAME.

ALFRED TYREE AND Co., of Lichfield Street, Christchurch, in the Dominion of New Zealand, Importers.

No. of class : 38.  
Description of goods : All goods included in this class.

No. of application : 10034.  
Date : 30th October, 1911.

TRADE MARK.

The words  
**IAO RANA SOAP.**

The essential particulars of this trade mark are the words "Iao Rana"; and any right to the exclusive use of the added matter is disclaimed.

NAME.

FITT AND CLAYTON, of Parnell, in the Provincial District of Auckland, in the Dominion of New Zealand, Soap-manufacturers.

No. of class : 47.  
Description of goods : Candles, common soap, detergents, illuminating, heating, or lubricating oils, matches and starch, blue and other preparations for laundry purposes—such as washing-powders, benzene.

No. of application : 10038.  
Date : 3rd November, 1911.

TRADE MARK.

The word  
**ERUPTITE.**

NAME.

ERUPTITE EXPLOSIVES COMPANY OF NEW ZEALAND, LIMITED, of Wellington, in the Dominion of New Zealand.

No. of class : 20.  
Description of goods : Explosives.

No. of application : 10042.  
Date : 6th November, 1911.

TRADE MARK.

**WOODBERRY**  
OZ.  
**U.S. ARMY DUCK**

The applicant company claims that the said trade mark has been used by them and their predecessors in business in respect of the article mentioned for twenty-eight years before the 1st day of January, 1890.

NAME.

MOUNT VERNON-WOODBERRY COTTON DUCK COMPANY, a corporation organized under the laws of the State of Delaware, United States of America, and doing business at the Continental Trust Building, Baltimore, Maryland, United States of America.

No. of class: 24.

Description of goods: Cotton duck for sails for shipping, belts, tents, car-covers, awnings, aprons for agricultural machines, and other purposes.

No. of application: 10043.  
Date: 6th November, 1911.

TRADE MARK



The applicant company claims that the said trade mark has been used by them and their predecessors in business in respect of the article mentioned for forty-eight years before the 1st day of January, 1890.

NAME.

MOUNT VERNON-WOODBERRY COTTON DUCK COMPANY, a corporation organized under the laws of the State of Delaware, United States of America, and doing business at the Continental Trust Building, Baltimore, Maryland, United States of America.

No. of class: 24.

Description of goods: Cotton duck for sails for shipping, belts, tents, car-covers, awnings, aprons for agricultural machines, and other purposes.

No. of application: 10044.  
Date: 6th November, 1911.

TRADE MARK.



The applicant company claims that the said trade mark has been used by them and their predecessors in business in respect of the article mentioned for twenty-three years before the 1st day of January, 1890.

NAME.

MOUNT VERNON-WOODBERRY COTTON DUCK COMPANY, a corporation organized under the laws of the State of Delaware, United States of America, and doing business at the Continental Trust Building, Baltimore, Maryland, United States of America.

No. of class: 24.

Description of goods: Cotton duck for sails for shipping, belts, tents, car-covers, awnings, aprons for agricultural machines, and other purposes.

No. of application: 10045.  
Date: 6th November, 1911.

TRADE MARK.



The applicant company claims that the said trade mark has been used by them and their predecessors in business in respect of the article mentioned for twenty-three years before the 1st day of January, 1890.

NAME.

MOUNT VERNON-WOODBERRY COTTON DUCK COMPANY, a corporation organized under the laws of the State of Delaware, United States of America, and doing business at the Continental Trust Building, Baltimore, Maryland, United States of America.

No. of class: 50 (subclass 7).

Description of goods: Cotton twine.

No. of application: 10050.  
Date: 7th November, 1911.

TRADE MARK.

The word

**DIABOLO**

The essential particular of this trade mark is the word "Diabolo."

NAME.

AKTIEBOLAGET PUMP-SEPARATOR, a corporation duly organized under the laws of Sweden, and located in Drottninggatan 66, in the City of Stockholm, Sweden, Manufacturers of and Dealers in Centrifugal Liquid-separators and Dairy Implements.

No. of class: 7.

Description of goods: Centrifugal milk-separators, milk-skimming apparatus, churns, milking-machines, milk-measuring apparatus, butter-workers, milk-coolers, pasteurizers, milk-testers, cheese-moulds, curd-mills, cheese-lyres, cheese-pressers, and cheese-vats.

No. of application: 10051.  
Date: 7th November, 1911.

TRADE MARK.



**SAMSON**

NAME.

WILLIAM HUNT AND SONS, THE BRADDES LIMITED, of Brades Steel Works, near Birmingham, England, Manufacturers.

No. of class: 12.

Description of goods: Cutlery and edge tools.

J. C. LEWIS,  
Registrar.

Trade Marks registered.

- LIST of Trade Marks registered from the 27th October to the 9th November, 1911, inclusive:—
- No. 7783/9780.—Watson Bros., Limited. Class 42. (*Gazette* No. 65, of the 10th August, 1911.)
  - No. 7784/9567.—W. A. and J. A. Macfarlane. Class 4. (*Gazette* No. 42, of the 18th May, 1911.)
  - No. 7785/9435.—The Vanda Company. Class 50. (*Gazette* No. 23, of the 23rd March, 1911.)
  - No. 7786/9548.—Martin, Sons, and Co. Class 34. (*Gazette* No. 46, of the 1st June, 1911.)
  - Nos. 7787/9760 and 7788/9761.—Hill and Plummer, Limited. Classes 1 and 15. (*Gazette* No. 65, of the 10th August, 1911.)
  - Nos. 7789/9765 and 7790/9766.—E. Shep. Dixon. Classes 44 and 42. (*Gazette* No. 65, of the 10th August, 1911.)
  - Nos. 7791/9128, 7792/9129, 7793/9130, 7794/9131, and 7795/9132.—Donaghy's Rope and Twine Company, Limited. Class 50. (*Gazette* No. 100, of the 17th November, 1910.)
  - No. 7796/9497.—Donaghy's Rope and Twine Company, Limited. Class 50. (*Gazette* No. 28, of the 6th April, 1911.)
  - No. 7797/9604.—The Dresden Pianoforte Manufacturing and Agency Company, Limited. Class 8. (*Gazette* No. 65, of the 10th August, 1911.)
  - No. 7798/9015.—R. Reed and E. D. Dunne. Class 3. (*Gazette* No. 86, of the 22nd September, 1910.)
  - No. 7799/9818.—Heer and Co. Class 31. (*Gazette* No. 69, of the 24th August, 1911.)
  - Nos. 7800/9155, 7801/9156, and 7802/9157.—Joosten and Murie. Class 10. (*Gazette* No. 104, of the 1st December, 1910.)
  - No. 7803/9813.—H. T. Gould. Class 3. (*Gazette* No. 69, of the 24th August, 1911.)
  - No. 7804/9730.—E. Collier. Class 3. (*Gazette* No. 62, of the 27th July, 1911.)
  - No. 7805/9443.—Abingdon-Ecco, Limited. Class 22. (*Gazette* No. 62, of the 27th July, 1911.)
  - No. 7806/9759.—D. and J. Anderson, Limited. Class 24. (*Gazette* No. 62, of the 27th July, 1911.)
  - No. 7807/9774.—The Austin Motor Company, Limited. Class 22. (*Gazette* No. 62, of the 27th July, 1911.)
  - No. 7808/9802.—Gollin and Co. Proprietary, Limited. Class 1. (*Gazette* No. 69, of the 24th August, 1911.)



**Trade Mark Renewal Fees paid.**

**F**EEES paid for the renewal of the undermentioned Trade Marks for fourteen years from the date first mentioned:—

No. 2184/1743.—19th October, 1911.—J. B. Gilberd and Sons, Limited, Wanganui, N.Z. 31st October, 1911.

No. 2238/1785.—23rd December, 1911.—Rudge-Whitworth, Limited, Coventry, England. 7th November, 1911.

No. 2252/1794.—24th January, 1912.—Kempthorne, Prosser, and Co's New Zealand Drug Company, Limited, Dunedin, Christchurch, Wellington, and Auckland, N.Z. 31st October, 1911.

No. 2251/1812.—21st January, 1912.—Jeye's Sanitary Compounds Company, Limited, London, Eng. 8th November, 1911.

No. 2236/1833.—5th March, 1912.—W. Heron, Sydney, N.S.W. 9th November, 1911.

**Subsequent Proprietors of Trade Marks registered.**

[NOTE.—The name of the former proprietor is given in brackets; the date is that of registration.]

**N**O. 89/86 (two marks).—Offley Forrester Limitada (existing under and by virtue of the laws of Portugal), of 90 Rua do Choupello, Villa Nova de Gaya, Portugal, Wine-shippers. (Offley Forrester and Co.) 2nd November, 1911.

No. 468/344.—Offley Forrester Limitada (existing under and by virtue of the laws of Portugal), of 90 Rua do Choupello, Villa Nova de Gaya, Portugal, Wine-shippers. (Offley Forrester and Co.) 2nd November, 1911.

No. 1957/1575.—Compagnie du Vin St. Raphael of St. Valence, Drôme, in France. (Clement et Cie.) 2nd November, 1911.

No. 1981/1596.—Macgregor, Caldbeck, and Co., of 1 Rangoon Street, Crutched Friars, London, England, Wine and

Spirit Merchants and Whisky-blenders. (T. P. Griffin and Co.) 2nd November, 1911.

Nos. 2480/1973 and 2481/1974.—Sen Sen Chiclet Company, a corporation organized under the laws of Maine, having an office at Portland, Maine, and doing business at Metropolitan Tower, New York City, New York, United States of America. (T. B. Dunn Company.) 2nd November, 1911.

No. 6370/5139.—Opera Omnia, Limited, of 4 Mermaid Court, Borough London, England, Manufacturers. (Applied Inventions, Limited.) 2nd November, 1911.

**Trade Marks removed from the Register.**

**T**RADe Marks removed from the Register owing to the non-payment of the renewal fee, from the 27th October to the 9th November, 1911, inclusive:—

No. 2074/1675.—2nd August, 1897.—Woodberry Manufacturing Company, Baltimore, U.S.A. Class 25.

No. 2075/1676.—2nd August, 1897.—A. E. Sykes, New Plymouth, N.Z. Class 3.

No. 2080/1710.—6th August, 1897.—S. Allen and Sons, Limited, Townsville, Queens. Class 43.

No. 2081/1689.—9th August, 1897.—The New Zealand Loan and Mercantile Agency Company, Limited, Wanganui, N.Z. Class 42.

**Trade Mark Registration cancelled.**

**T**HE entry on the Register in respect of the following trade mark has been cancelled at request of proprietors:—

No. 8252/6554.—H. Berry and Co. (Application and registration advertised respectively in Supplements to *New Zealand Gazette*, No. 85, of the 7th October, 1909, and No. 2, of the 13th January, 1910.)

# ILLUSTRATIONS OF INVENTIONS.

[These illustrations refer to the complete specifications accepted, and advertised in this *Gazette*.]

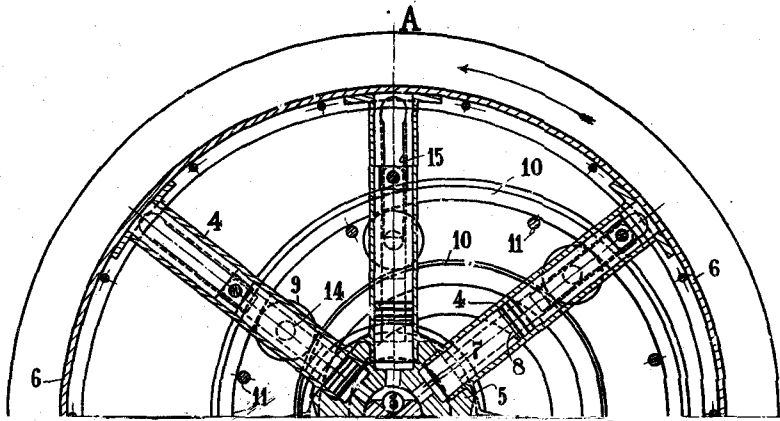

*Hydraulic transmission apparatus. Hele, Shaw & Martineau. 30213*

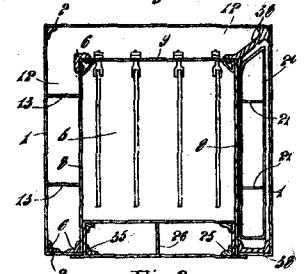
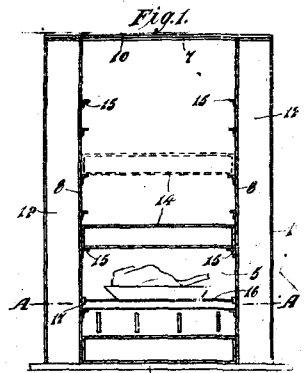

*Fig. 2. Coaker, electric. Kirkwood. 30163.*

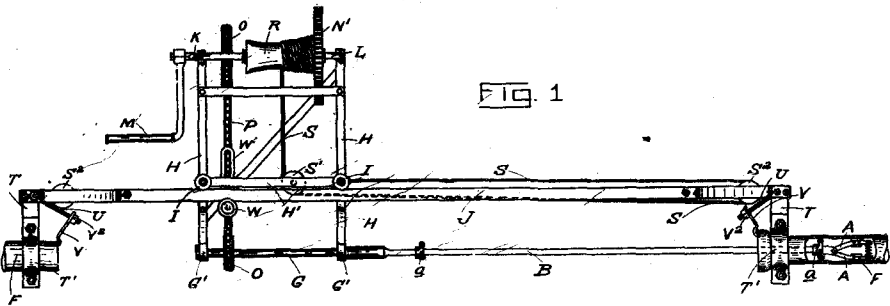

*Water-pipe cleaner. Hill. 29156.*

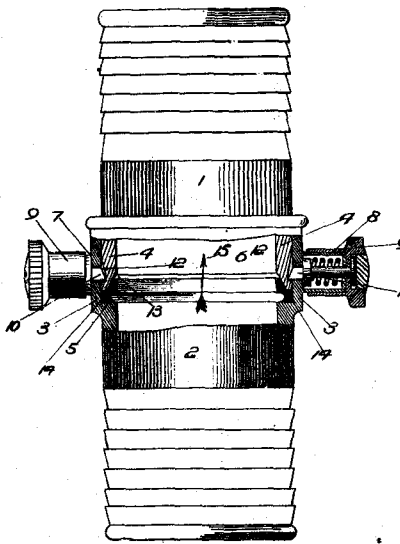

*Hose coupling. 30061.*

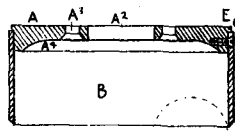
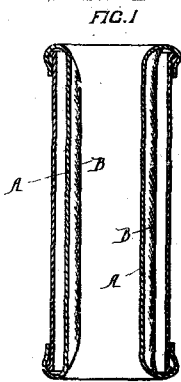

*Skiving machine knife. Pallet. 30103.*

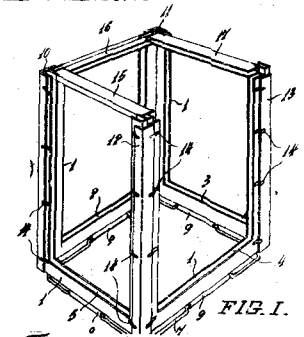

*Forcing frame. Ponder. 30166.*

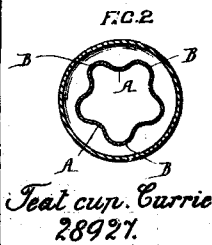

*Teat cup. Currie 28927.*

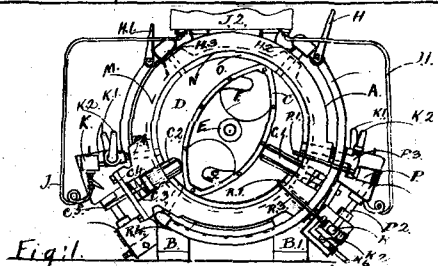

*Rotary engine. Fair. 28799.*

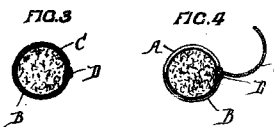

*Cigarette-holder. James. 30246.*

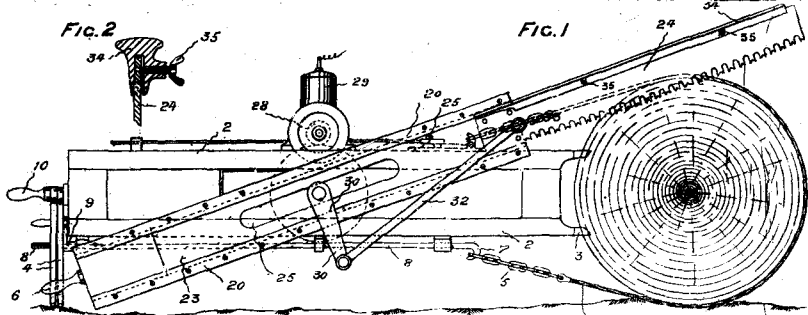

*Power operated saw. Goehler. 30160.*

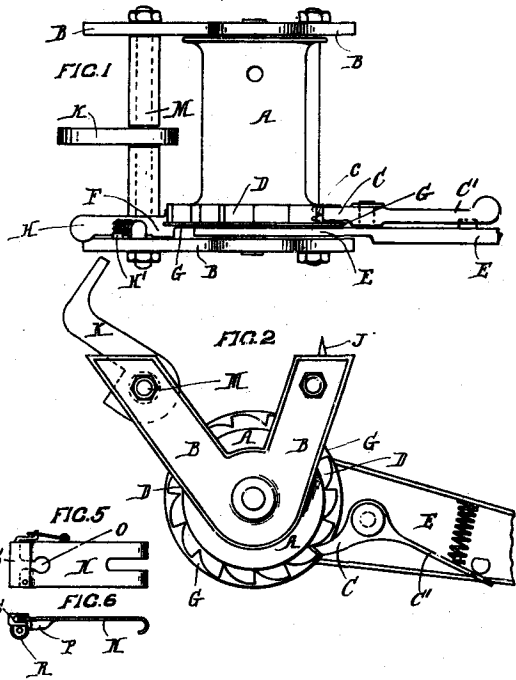

Wire strainer. Hunter. 28752.

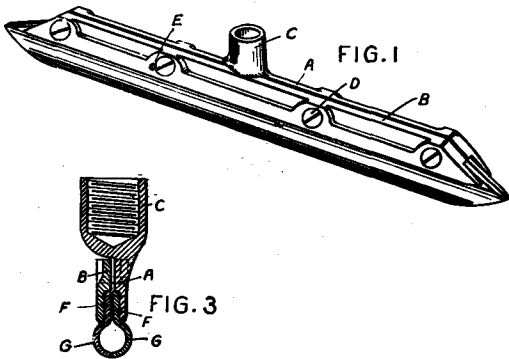

Trolley line car. Green. 30206.

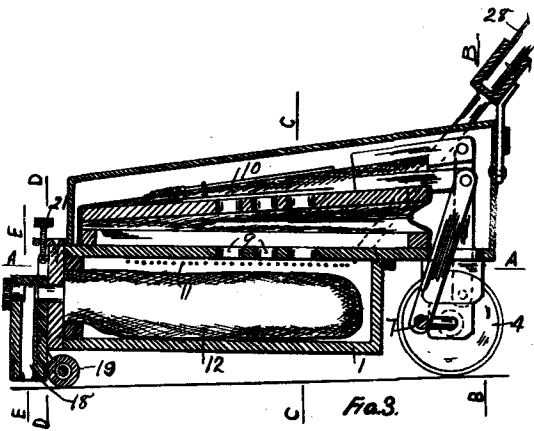

Vacuum sweeper. Smith (Domestic Vacuum Sweeper Co. - Quist & Blanch) 30168.

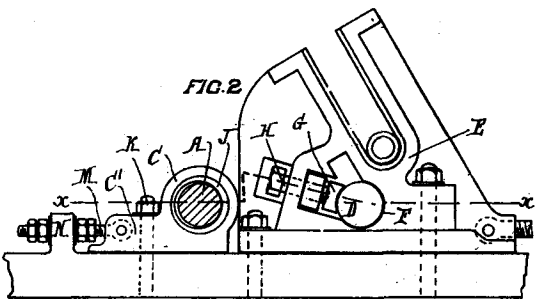

Flax stripper. Greig. 30154.

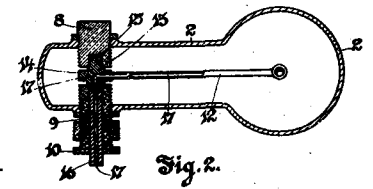
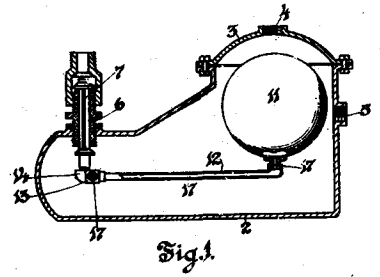

Liquid control float. Pomninghaus. 30170

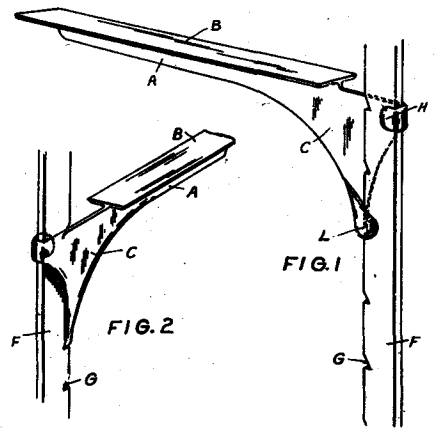

Shelf bracket. M. F. P. & W. J. Loundar. 30204

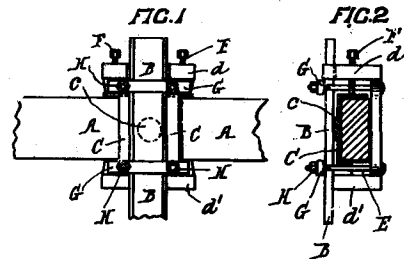

Securing plough skid to beam. Carl. 29244.

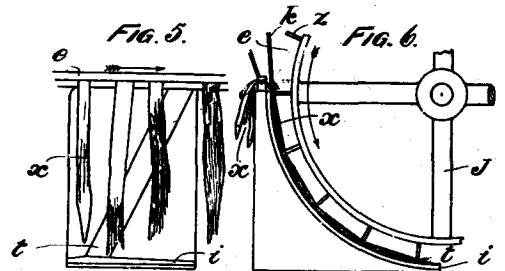
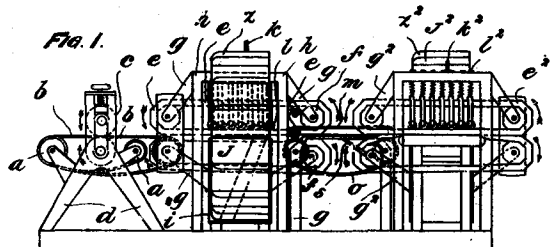

Decorticator. Downham. 28385.

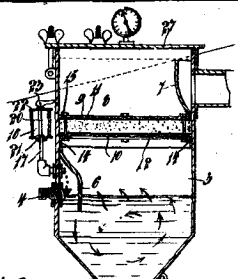

30249. Vacuum cleaner. Hursthouse.

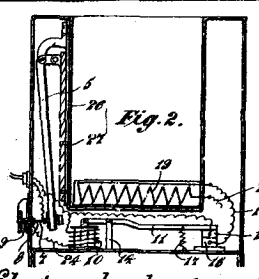

Electrical cooker etc control. Kirkwood. 28694.

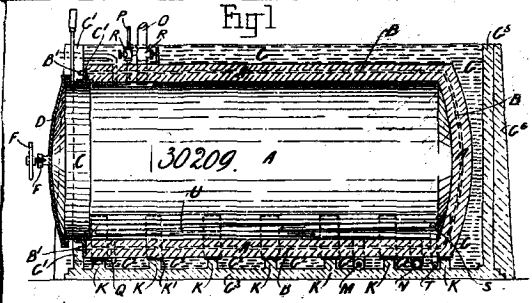

Vacuum chamber. Dennis & Fidler.

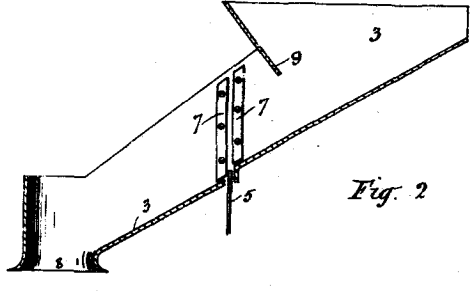

Chute cut-off. Grosser. 30182.

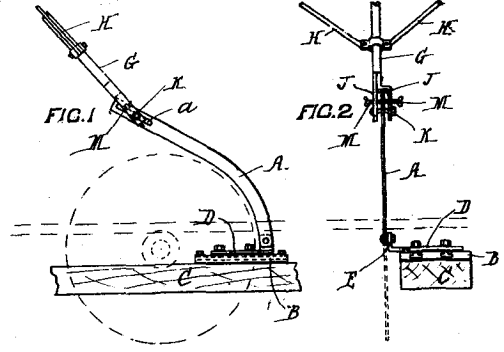

Circular saw guard. Fothergill & Rogers. 28880.

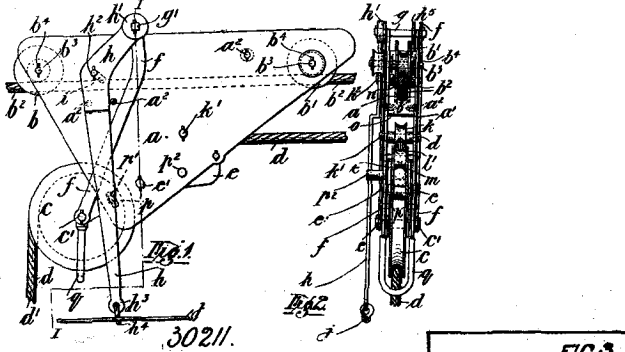

Cargo etc raiser & conveyor. Mc Bay.

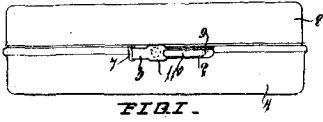
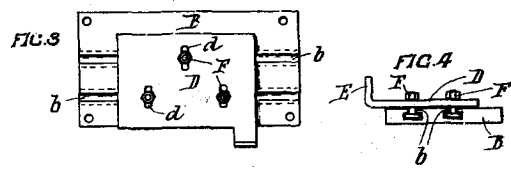

Boot-blacking container. Saine (Sinclair) 30232.

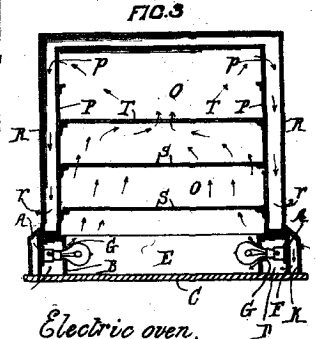

Electric oven. Martin. 28823.

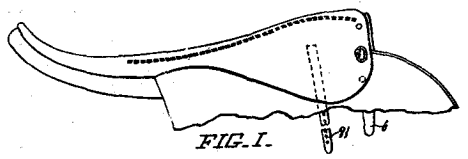

Saddle. Downing. 30226.

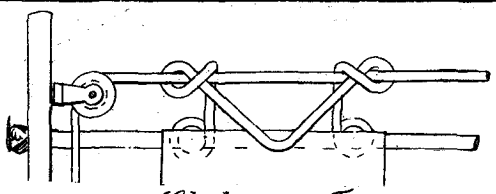
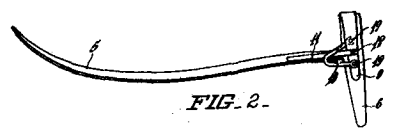

Clothespeg. Tait. 28798.

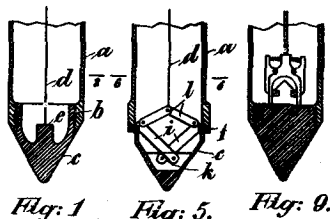

Concrete pile shoe. Kahn. 30194.

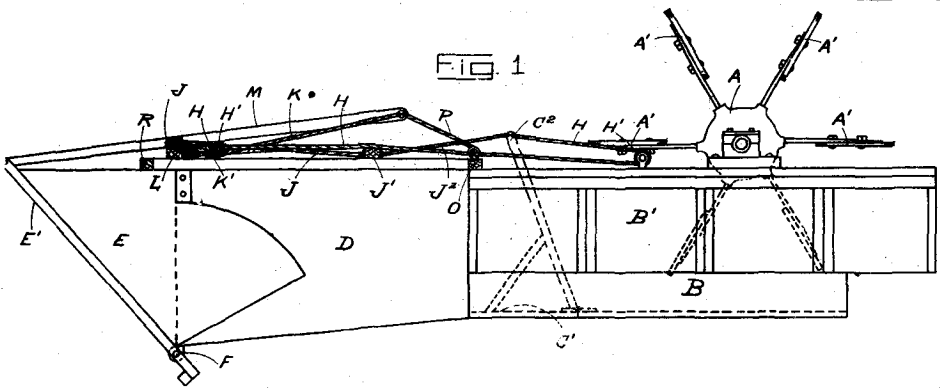

Water power developer. Shaw. 30222.

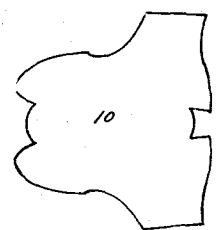

Boot manufacture. Levy. 29723.

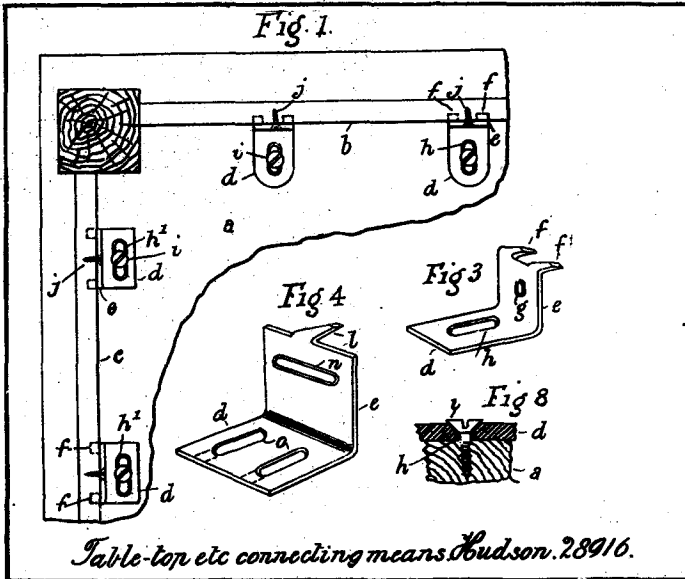
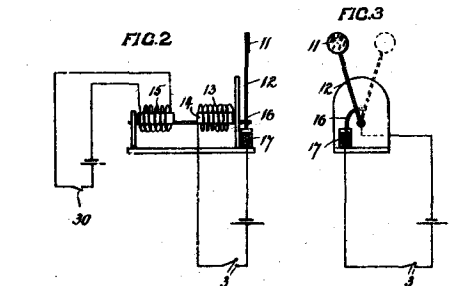
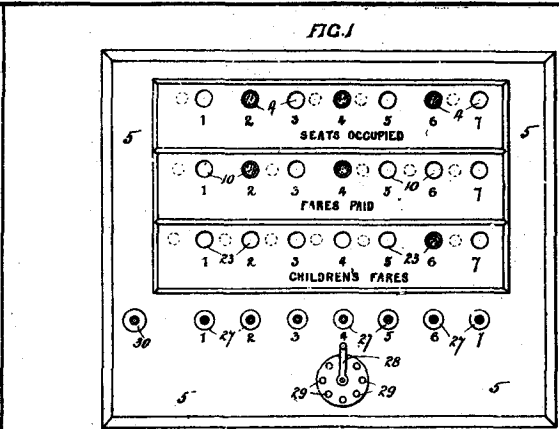
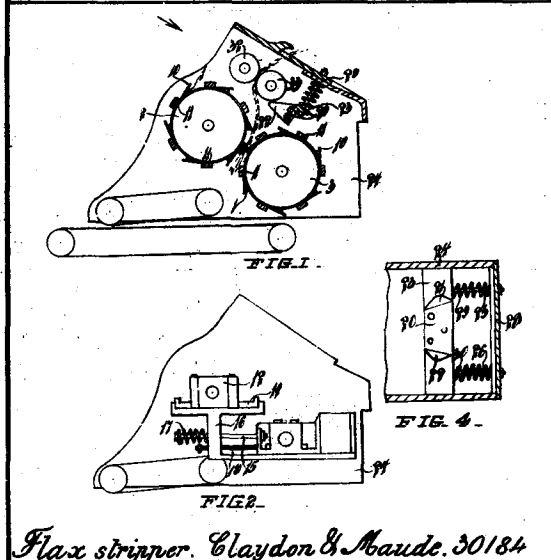

Table-top etc connecting means Hudson. 28916.



Car fare collector etc. Masters. 29791.



Flax stripper. Clayton & Maude. 30184

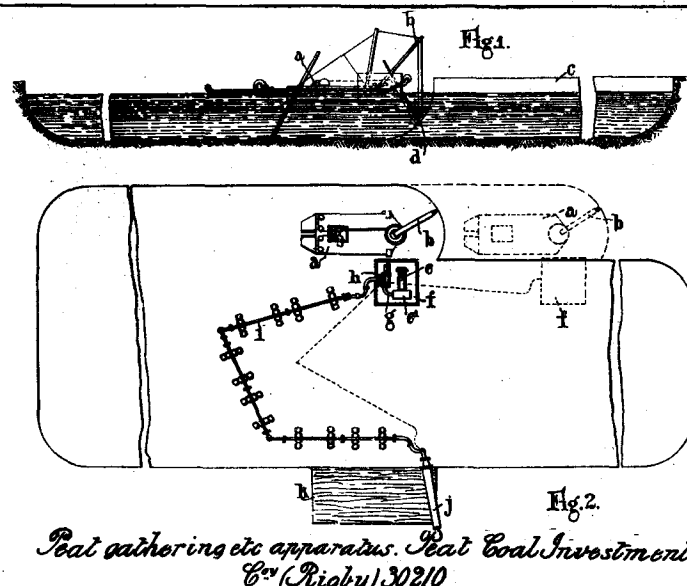

Boat gathering etc apparatus. Boat Coal Investment Co. (Rigby) 30210

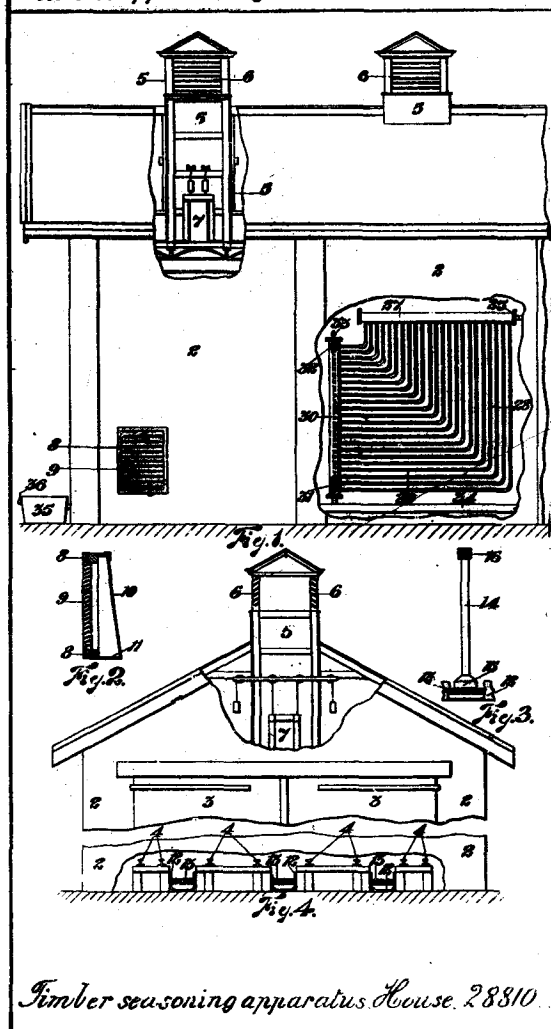

Timber seasoning apparatus House. 28810

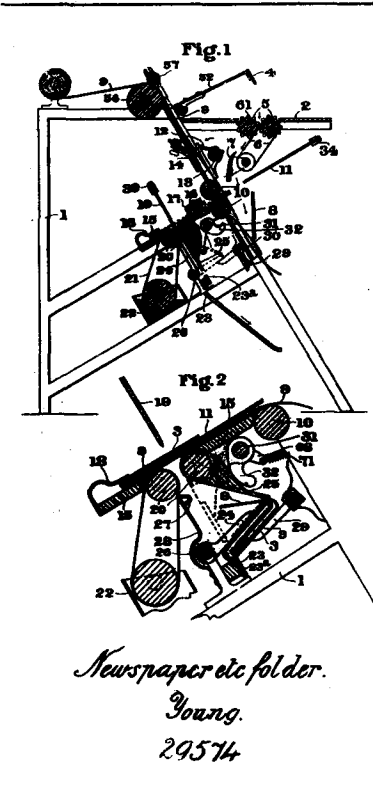

Newspaper etc folder. Young. 29574

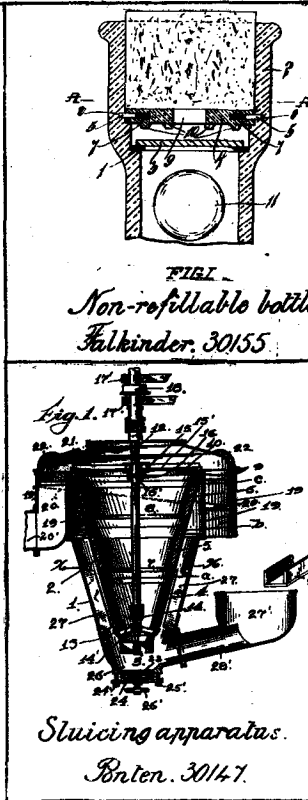

Non-refillable bottle. Falkinder. 30155

Sluicing apparatus. Borten. 30147